



Metrix Electronics Limited

Minchens Court, Minchens Lane, Bramley, RG26 5BH, U.K.

Tel: +44 (0)845 034 3234, Fax: +44 (0)845 034 3233

E-mail: sales@metrix-electronics.com, Web: www.metrix-electronics.com

RECORDERS

8440 – DAS1400 – DAS600

USER'S MANUAL

We wish to thank you for acquiring a recorder by SEFRAM and for trusting our company. The main goal of our different teams (design office, production, commercial, after-sale service...) is to match with accuracy your needs by designing or updating high technology products.

You will find with your recorder a CD-ROM including:

- The user's manual of the 8440, DAS1400 and DAS600 appliance
- the "SeframViewer" software that allows you to save and work with your recording files under Windows®.
- the Sefram Pilot software allows you to you can connect your computer to a recorder and create setup files.

We would like you to read carefully this user's manual for an optimum use of your recorder.

For any other information, our teams are at your disposal:



Commercial service e-mail: sales@sefram.fr

After-sales service e-mail: sav@sefram.fr

Technical help e-mail: support@sefram.fr

Fax: +33 (0)4 77 57 23 23

Web: www.sefram.fr



Metrix Electronics Limited

Minchens Court, Minchens Lane, Bramley, RG26 5BH, U.K.

Tel: +44 (0)845 034 3234, Fax: +44 (0)845 034 3233

E-mail: sales@metrix-electronics.com, Web: www.metrix-electronics.com

Copyright Sefram, 2008. All rights reserved

Any copy of this document, totally or partially, is submitted to an autorisation by Sefram.

GARANTY

Your instrument is guaranteed for one year in parts and work time against any default of manufacture and/or contingencies in the functioning. This guaranty starts at the date of delivery and ends 365 calendar days later.

If the appliance is subject to a guaranty contract, this contract cancels and replaces the above mentioned conditions of guaranty.

This guaranty does not include any fault of use and/or error of handling.

In case of use of the guaranty, the user must send back the concerned appliance to our factory:

SEFRAM Instruments & Systèmes

Service Après-Vente
32, rue Edouard MARTEL
BP 55
42009 SAINT-ETIENNE CEDEX 2

The accessory items furnished as standard with the appliance (cables, plugs...) and the optional accessory items (bag, case...) are guaranteed for 3 months against any default of manufacture.

The factory options in the appliance are guaranteed for the same time as the appliance.

What to do in case of malfunction?

In case of malfunction or for any problem of use, please join the technical assistance by SEFRAM Instruments & Systems.

A technician will take your call in charge and will give you any necessary information to solve your problem.

What to do in case of crash?

In case of crash of the appliance, please join our after-sales service.

Some advice?

Some technical help required?

SEFRAM Instruments & Systems commits itself to help you by phone for the use of your appliance. Please phone:

(00 33) 825 56 50 50 Technical help for products

or send an e- mail to: support@sefram.fr

CONTENTS

1. IMPORTANT INFORMATION	1.1
1.1. CAUTIONS	1.1
1.2. SECURITY INSTRUCTIONS	1.1
1.3. SYMBOLS AND DEFINITIONS	1.2
1.4. CONFORMITY AND RESTRICTIONS OF THE APPLIANCE	1.2
2. PRESENTATION	2.1
2.1. GENERAL	2.1
2.2. DESCRIPTION	2.2
2.2.1. Rear side (or top side)	2.2
2.2.2. Front side.....	2.3
2.3. THE LCD SCREEN	2.4
2.3.1. Description of screen.....	2.4
2.4. KEYS.....	2.5
2.5. THUMB WHEEL.....	2.6
2.6. LOCKING THE KEYBOARD.....	2.6
2.7. USE OF A MOUSE	2.6
2.8. USE OF AN EXTERNAL KEYBOARD	2.6
2.9. UPDATING THE INTERNAL SOFTWARE	2.7
2.10. USE OF THE SUPPORT LEG OF CHART RECORDER	2.7
3. INITIALISATION AND PRECAUTIONS OF USE	3.1
3.1. CHART RECORDER: LOADING THE RECORDING PAPER.....	3.1
3.1.1. Storage precautions of the records.....	3.2
3.2. POWER SUPPLY	3.2
3.2.1. Fuse	3.2
3.2.2. Power up of the chart recorder.....	3.3
3.2.3. Power up of paperless recorders	3.4
3.3. CONFIGURATION ON POWER-UP.....	3.4
3.4. CONNECTION TO THE MEASURE NETWORK.....	3.5
3.4.1. Measure of voltage.....	3.5
3.4.2. Measure of temperature with a thermocouple	3.5
3.4.3. Measurement on bridge	3.5
3.4.4. Measure of temperature with a PT100 or PT1000	3.7
3.4.5. Measure of intensity.....	3.8
3.4.6. Connection of the grounding	3.8
3.5. ROUTINE MAINTENANCE	3.9
3.6. CALIBRATION OF THE OFFSETS	3.9
3.7. FACTORY ADJUSTEMENT	3.10
4. USE.....	4.1
4.1. « MODE » KEY.....	4.1
4.2. « HELP » KEY	4.2
4.3. « SET UP » KEY	4.3
4.4. « CHART » KEY	4.5
4.5. « CHANNELS SET UP» KEY.....	4.6
4.5.1. Analogical channels.....	4.6
4.5.2. Function between channels.....	4.8
4.5.3. Logic channels.....	4.9
4.6. « CHANNEL ON/OFF» KEY	4.10
4.7. « DISPLAY » KEY.....	4.11

4.7.1.	<i>Display F(t) (oscilloscope mode)</i>	4.11
4.7.2.	<i>Display XY</i>	4.13
4.7.3.	<i>Digital display</i>	4.13
4.8.	DIRECTION KEYS.....	4.13
4.9.	« TRIGGER » KEY	4.14
4.10.	« REPLAY » KEY	4.15
4.11.	« START/STOP » KEY	4.16
4.12.	PAPER-FEED KEY.....	4.17
4.13.	SCREEN COPY.....	4.17
5.	DIAGRAMS	5.1
5.1.	POSITIONS OF THE CHANNELS	5.2
5.2.	CHANGE DIAGRAMS	5.3
6.	TRIGGERS	6.1
6.1.	TRIGGERING WITH ANALOGICAL CHANNELS	6.2
6.1.1.	<i>Single threshold</i>	6.2
6.1.2.	<i>Several thresholds</i>	6.3
6.1.3.	<i>Trigger according to thresholds</i>	6.4
6.1.4.	<i>Trigger according to the slope</i>	6.5
6.2.	TRIGGERING WITH LOGICAL CHANNELS	6.6
7.	MATHEMATICAL CALCULATIONS	7.1
7.1.	DEFINITIONS	7.1
7.2.	TYPES OF CALCULATIONS	7.2
8.	DIRECT MODE	8.1
8.1.	CONFIGURATION OF THE PLOTTING.....	8.1
8.2.	TRIGGERING PLOTTING	8.3
8.3.	REARMAMENT OF THE PLOTTING	8.5
8.4.	WRITING DATA	8.5
8.5.	EXAMPLE OF PLOTTING PROGRAM	8.5
9.	MEMORY MODE	9.1
9.1.	CONFIGURATION AND TRIGGERING OF THE ACQUISITION	9.1
9.2.	SAMPLING PERIOD.....	9.3
9.3.	INTERNAL MEMORY, BLOCKS	9.3
9.4.	TRIGGERING POSITION	9.3
9.5.	DOUBLE TRIGGER MODE.....	9.4
9.6.	RECORDING.....	9.5
9.7.	MEMORY OUTPUT	9.7
10.	GO/NOGO MODE	10.1
10.1.	CONFIGURATION AND TRIGGERING OF THE ACQUISITION	10.1
10.2.	CREATION OF THE FRAME	10.2
10.3.	USE OF THE FRAME	10.4
11.	FILE MODE	11.1
11.1.	CONFIGURATION AND START OF THE ACQUISITION	11.1
11.2.	ANNOTATION	11.2
11.3.	LIMITS.....	11.3
11.3.1.	<i>Binary file</i>	11.3
11.3.2.	<i>Ascii file</i>	11.3
12.	POWER ANALYSER	12.1
12.1.	PRESENTATION.....	12.1
12.1.1.	<i>Installation: Menu "SET UP. Channel"</i>	12.2
12.1.2.	<i>Visualisation of the signal</i>	12.4
12.1.3.	<i>Selection of the acquisition parameters: Menu "TRIGGER"</i>	12.6
12.1.4.	<i>Acquisition</i>	12.7
12.1.5.	<i>Measurement methods</i>	12.7

13. FILE MANAGEMENT	13.1
13.1. GENERAL.....	13.1
13.2. MANAGEMENT OF THE CONFIGURATION FILES	13.2
13.2.1. Saving the configuration files.....	13.3
13.2.2. Loading the configuration files	13.4
13.3. MANAGEMENT OF THE ACQUISITION FILES	13.4
13.3.1. Saving the acquisitions.....	13.4
13.3.2. Loading the acquisition files	13.6
13.4. PC SOFTWARE FOR ANALYSIS	13.6
13.4.1. File transfer with FTP.....	13.7
13.4.2. Display with VIEWER software	13.8
14. PRINTING WITH PAPERLESS RECORDER.....	14.1
14.1. PLOT SET UP AND LAUNCH.....	14.1
14.2. PRINTER SETUP	14.3
15. INPUTS / OUTPUTS	15.1
15.1. ADDITIONNAL INPUT / OUTPUT CONNECTOR.....	15.1
15.2. LOGICAL INPUTS.....	15.2
15.2.1. Use	15.2
15.3. ALARM OUTPUTS	15.3
15.3.1. Use	15.3
15.4. POWER SUPPLY OUTPUT	15.3
15.5. KEYBOARD INPUT.....	15.3
15.6. MOUSE INPUT	15.4
15.7. XGA SCREEN OUTPUT	15.4
15.8. RS232	15.4
15.9. USB INTERFACE.....	15.5
15.10. ETHERNET RJ45 INTERFACE	15.5
15.11. EXTENSION BOX FOR DIGITAL INPUT OUTPUT	15.5
16. ETHERNET INTERFACE	16.1
16.1. INTERFACE ETHERNET.....	16.1
16.1.1. Generality	16.1
16.1.2. Using NTP.....	16.2
16.2. PROGRAMMING LANGUAGE	16.3
16.2.1. Format of the reception messages.....	16.3
16.2.2. Format of the emission messages.....	16.5
16.3. STANDARD INSTRUCTIONS	16.6
16.4. INDICATION OF THE STATUS OF THE APPLIANCE	16.7
16.4.1. Structure of the status data	16.7
16.4.2. Registers of service request.....	16.8
16.4.3. Registers of standard events.....	16.9
16.4.4. Register of the alarms	16.10
16.4.5. Using the structure of status data	16.11
16.5. PROGRAMMING DICTIONARY	16.12
16.5.1. Setup.....	16.12
16.5.2. Parameters of the channels.....	16.13
16.5.3. Functions of the channels and between the channels.....	16.14
16.5.4. Chart	16.15
16.5.5. Triggerings.....	16.16
16.5.6. Triggers.....	16.17
16.5.7. Memory/File mode	16.18
16.5.8. Reloadings, real-time savings	16.18
16.5.9. Launching plotting and recording.....	16.19
16.5.10. Diagrams.....	16.19
16.5.11. Direct display.....	16.20
16.5.12. Mathematics functions	16.20
16.5.13. Replay (memory output).....	16.21
16.5.14. Service request.....	16.21
16.6. ERROR MESSAGES.....	16.22

17. TECHNICAL SPECIFICATIONS	17.1
17.1. ISOLATED INPUTS	17.1
17.1.1. General characteristics	17.1
17.1.2. Voltage recording	17.1
17.1.3. RMS recording	17.2
17.1.4. Temperature recording	17.2
17.1.5. Frequency record:	17.2
17.1.6. Count Record	17.2
17.1.7. Sampling	17.3
17.1.8. Bandwidth	17.3
17.2. MULTIPLEXED INPUTS	17.4
17.2.1. General characteristics	17.4
17.2.2. Voltage recording	17.4
17.2.3. RMS recording	17.4
17.2.4. Temperature recording	17.5
17.2.5. Sampling	17.5
17.2.6. Bandwidth	17.5
17.3. MEASUREMENT BRIDGE INPUTS	17.6
17.3.1. General characteristics	17.6
17.3.2. Tension recording	17.6
17.3.3. RMS recording	17.6
17.3.4. Derived and integral recording	17.7
17.3.5. Gauge type recording	17.7
17.3.6. Temperature recording	17.7
17.3.7. Sampling	17.7
17.3.8. Bandwidth	17.7
17.4. SUPPLEMENTARY INPUTS / OUTPUTS	17.7
17.4.1. Logical channels	17.7
17.4.2. Alarm outputs	17.8
17.4.3. External power supply	17.8
17.5. POWER ANALYSIS	17.8
17.5.1. Ranges and Specifications for Tension and Intensity	17.8
17.5.2. Frequency	17.9
17.5.3. Power factor	17.9
17.5.4. Peak and peak factor	17.9
17.5.5. Harmonic rates, calculated in power analysis	17.9
17.6. PAPER	17.9
17.7. DISPLAY	17.10
17.8. MEMORY ACQUISITION	17.10
17.9. FILE ACQUISITION	17.10
17.10. COMMUNICATION INTERFACE	17.10
17.11. MISCELLANEOUS	17.10
17.11.1. USB Connectors	17.10
17.11.2. Screen connector	17.10
17.12. ENVIRONMENTAL CONDITIONS FOR CHART RECORDER	17.11
17.12.1. Weather conditions	17.11
17.12.2. Mains power supply	17.11
17.12.3. Dimensions, weight	17.11
17.13. ENVIRONMENTAL CONDITIONS FOR PAPERLESS RECORDERS	17.11
17.13.1. Weather conditions	17.11
17.13.2. Mains power supply	17.11
17.13.3. Dimensions, weight	17.11
17.14. ELECTROMAGNETIC COMPATIBILITY , SECURITY	17.12
17.14.1. Electromagnetic compatibility	17.12
17.14.2. Secutity, Isolation Class, Installation Category	17.13
17.15. MISCELLANEOUS	17.13
17.15.1. Internal saving battery	17.13
17.16. ACCESSORY ITEMS	17.14
17.16.1. Items furnished with the appliance	17.14
17.16.2. Optional accessory items	17.14
17.16.3. Expandable items (optional)	17.14

18. APPENDIX	18.1
18.1. INFORMATION ABOUT THE RANGES OF THE INPUTS.....	18.1
18.1.1. <i>Voltage isolated inputs</i>	18.1
18.1.2. <i>Multiplexed voltage input</i>	18.2
18.1.3. <i>Thermocouple input</i>	18.2
18.2. ACCURACY OF THERMOCOUPLE MEASUREMENTS.....	18.3
18.3. ACCURACY OF THE PT100 MEASUREMENT.....	18.4
18.4. ACCURACY OF INSTANTANEOUS MEASUREMENT AS A FUNCTION OF FILTER	18.5
18.5.	18.5
18.6. NOTE ON THE MEASUREMENT UNITS IN MEASUREMENT BRIDGE.....	18.5
18.6.1. <i>Conversion rules</i>	18.5
18.6.2. <i>Calculation details</i>	18.6
18.6.3. <i>Characteristic value for a bridge in mV/V</i> :.....	18.7
18.6.4. <i>Example of a change of unit</i> :	18.7

1. IMPORTANT INFORMATION

Please read the following instructions carefully before using your recorder

1.1. Cautions

Do not use the product for any other purpose than those intended.

Use normalised cables for connecting the appliance to the points of measure.

Use the power cable provided to avoid any damage to the appliance and to ensure its measuring characteristics.

To prevent any electric shock hazard, never plug or unplug the measuring cables when they are connected to an electric power supply.

Do not use in wet environment.

Do not use in explosive environment.

In case of failure or for the maintenance of the appliance, only qualified personnel should be allowed to intervene. In such a case, it is necessary to use spare parts by Manufacturer.

Do not open the appliance when alive.

1.2. Security instructions

For a correct use of the appliance, it is necessary that users abide by the security measures as described in this manual.

Some specific warnings appear all along this manual.

In case of needs, warning symbols are shown on the appliance:



This is a CLASS 1 appliance: any inner or outer electric default of the appliance in relation with its use is evacuated to the ground that ensures the security of the user.



YOU MUST NOT unplug the protective grounding of the appliance

1- Important information

1.3. Symbols and definitions

Symbols that appear in this manual:



Warning: potential danger for the user



Attention: potential danger for the appliance and/or the connected equipment



Remark: Important information

Symbols that appear on the appliance:



Danger (High Voltage): immediate corporal hazard



Attention: refer to the manual. Possibility of damages to the connected equipment or to the appliance itself.



Grounding: reachable parts bound to the grounding of the appliance

1.4. Conformity and restrictions of the appliance

The chart recorder, Paperless recorders are in conformity with CEI 61010-1 (2001-02).

See chapter "Technical specifications".



Attention: Never set a voltage higher than the maximum admissible voltage between the terminals and relatively to the ground.

2. PRESENTATION

2.1. GENERAL

The chart recorder and paperless recorders are programmable recorders designed to measure and record on 6 to 36 analogical channels, voltages, currents, temperatures, etc. and 16 logical channels (event markers).

The chart recorder appliance has a built-in thermal printer for real-time signals recording. It is suitable with 6 to 36 analogical channels isolated or multiplexed non-isolated .

The PAPERLESS RECORDER (6 TO 36 CHANNELS) is identical to the chart recorder but without real-time recording on paper. It is suitable with the same kind and number of channels.

The 6 channels paperless recorder - more compact -, is the same than 6 isolated channels model.

3 types of inputs are proposed:

- isolated inputs through 6-channels modules, up to 3 modules
- non-isolated differential inputs, multiplexed by 12-channel modules, up to 3 modules.
- Isolated inputs through 6-channels gauge bridge modules

It has various functioning modes:

- a Direct mode, for acquisition printed on paper, available only on chart recorder
- a Memory mode, for acquisition on quick inner memory
- a File mode, for acquisition on inner hard drive or USB key
- a GoNogo mode, for acquisition on a pre-recorded frame.

The "operator-recorder" dialog is made easier thanks to easy-to-read menus on a wide LCD screen. The measuring parameters are easy to program. You can program the parameters through the keyboard and the thumb wheel on the front side, or through a mouse and an external keyboard.

The chart recorder and paperless recorders can be entirely programmed through an Ethernet link.



2-Presentation

2.2. DESCRIPTION

All kind of recorder have the same inputs / outputs connectors at the rear side for the chart recorder, or at the top side for the paperless recorders.

2.2.1. Rear side (or top side)

- 1- a RJ45 connector for the ETHERNET 10/100BaseT interface
- 2- a SUB-D 9-pin connector (RS232 not used)
- 3- a SUB-D 15-pin connector for an external screen type XGA (1024 x 768)
- 4- a MINI-DIN connector for the mouse type PC PS2
- 5- a MINI-DIN connector for the keyboard type PC PS2
- 6- 4 USB connectors for keyboard and mouse type PC, or for memory keys
- 7- a SUB-D 25-pin connector for the 16 logical inputs and a few alarm outputs
- 8- access to the 3 modules A, B, C of the inputs (isolated or not according to the configuration of the appliance)
- 9- grounding terminal
- 10- ON/OFF switch
- 11- mains socket

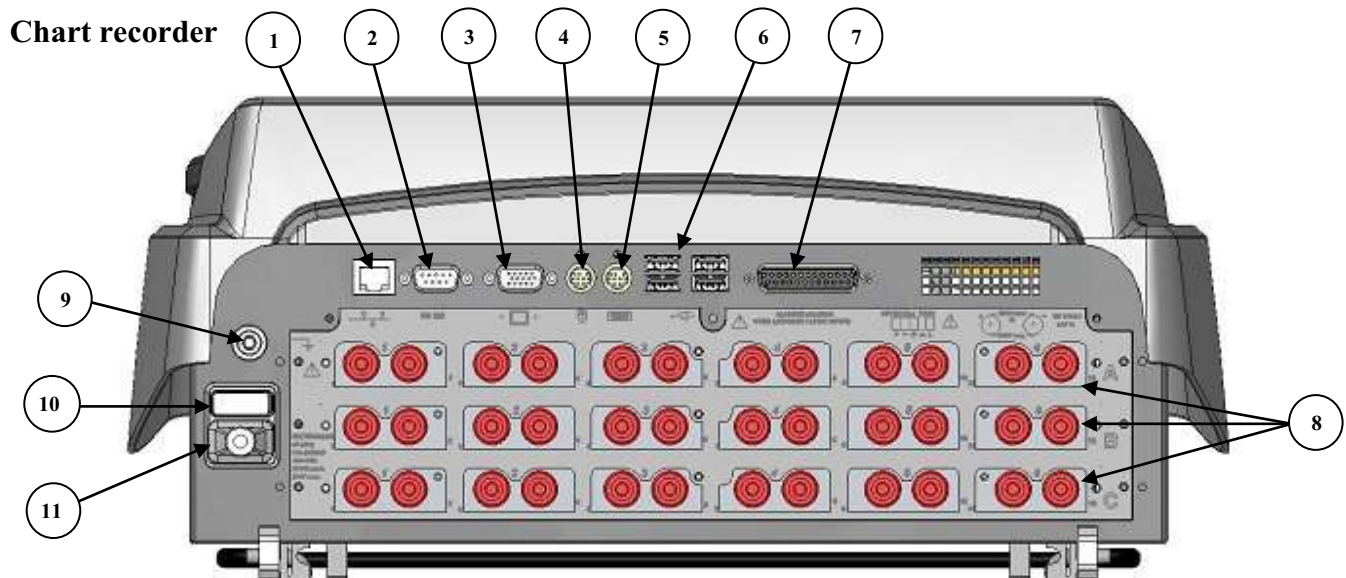

Paperless recorders

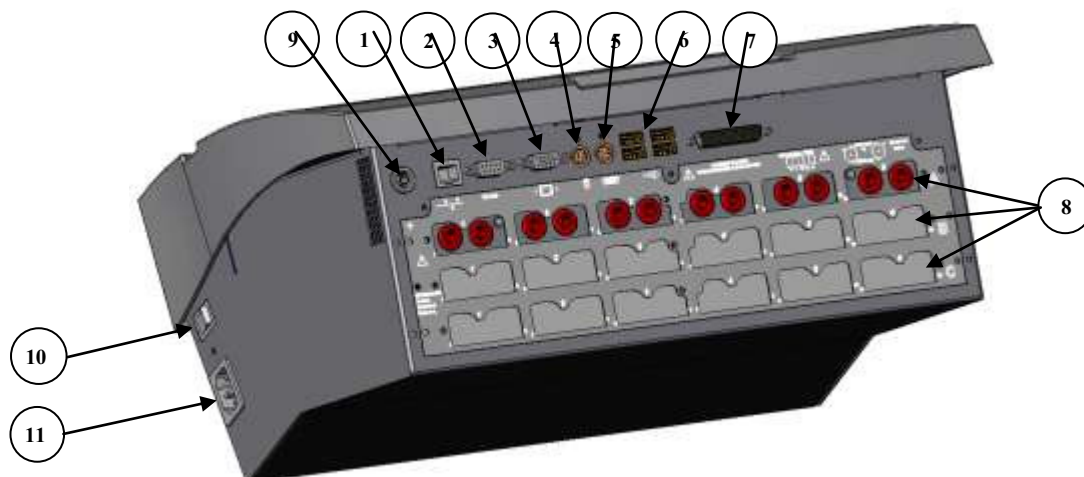

Isolated input modules include for each input 2 safety terminals :

- 1 red terminal : input "+"
- 1 black terminal : input "-"

Non-isolated differential input modules include for each input 5 screw terminals :

- 2 terminals marked + and – for the voltage input
- 2 terminals marked I+ and I- for the PT100 input
- 1 grounding terminal

For all other input / output, see chapter "**Inputs / Outputs**".

2.2.2. Front side

The front side of the recorders includes:

- a colour LCD back-lit TFT screen
- a keyboard with function keys and menu keys
- a thumb wheel
- a set including a printing table and paper-feed for the chart recorder

2.3. THE LCD SCREEN



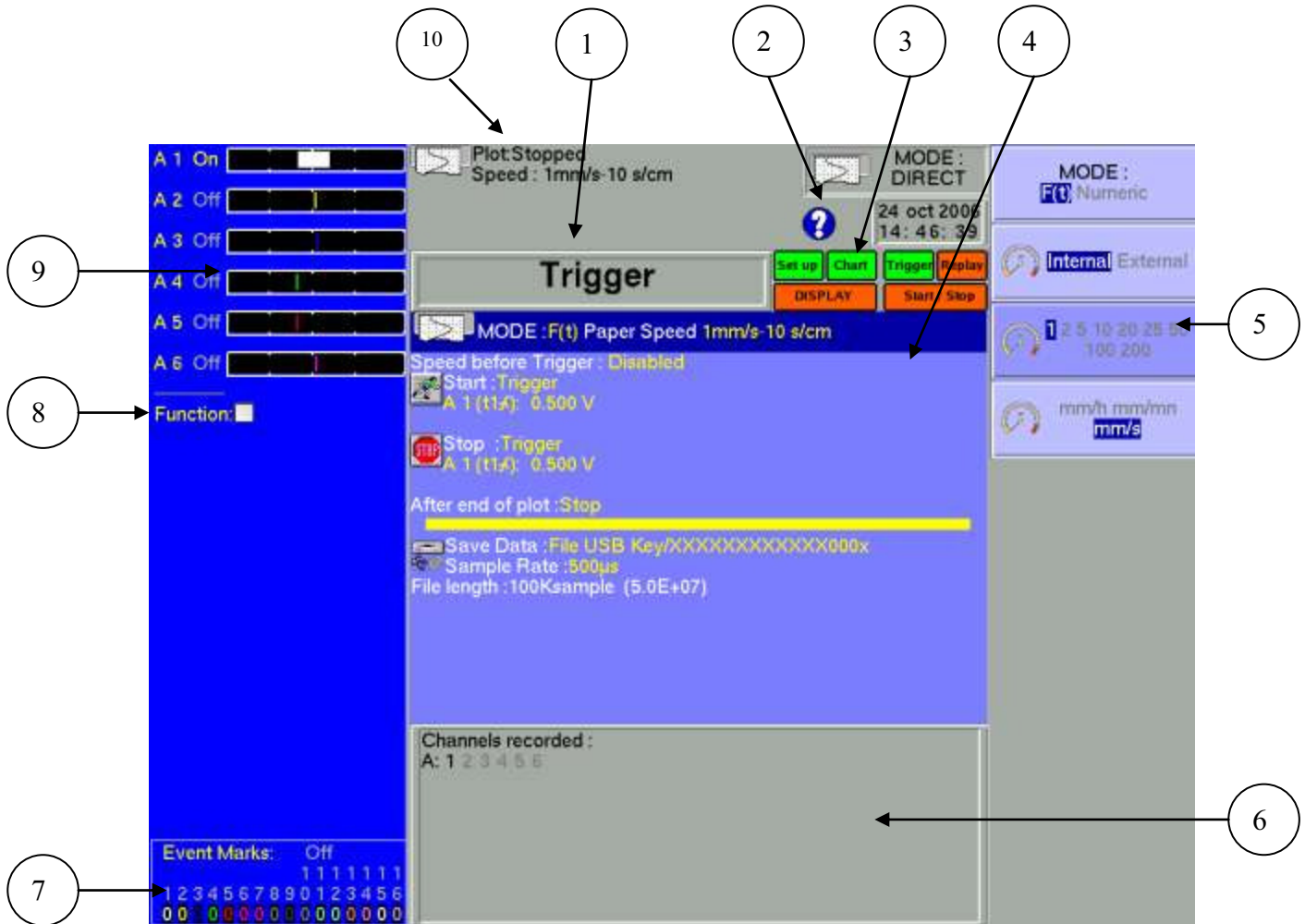









2.3.1. Description of screen



Various zones on the screen:

- 1- TITLE of the current menu (except for a few visualisation menus)
- 2- HELP: access to in-line assistance and user's manual
- 3- FUNCTIONS: access to the main functions with the mouse; has the same functions as the front side keyboard
- 4- PARAMETERS: names of the set-up parameters and their current values
- 5- VALUES: possible values of the parameters currently modified; selection through a key from F1 to F10 then modification with the thumb wheel or directly with the mouse or the external keyboard
- 6- INFORMATION relative to the acquisition (validated inputs, total acquisition time, positions of the triggers...)
- 7- LOGICAL INPUTS: real-time status of the logical channels
- 8- FUNCTION : calculation functions between the channels
- 9- ANALOGICAL INPUTS: bargraph of the current values of the inputs
- 10- GENERAL STATE: mode of acquisition, date and hour, status of the acquisition or the printing.

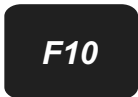

2.4. KEYS

- 
 - « **MODE** »: choice of the functioning mode of the recorder: **DIRECT (chart recorder only), MEMORY, GONOGO** or **FILE**
- 
 - « **HELP** »: displays a "help" window or the user's manual
- 
 - « **SET UP** »: general configuration of the appliance (language, date and hour, alarm outputs, update of the inner software...)
- 
 - « **CHART** »: parameters of the printing on thermal paper (chart recorder only)
- 
 - « **CHANNEL SET UP** »: access to the parameters of each channel, access to the functions between channels
- 
 - « **CHANNEL ON/OFF** »: choice of the channels to be in each acquisition (on paper, on screen, in inner memory and on file)
- 
 - « **DISPLAY** »: printing on screen of the validated channels (in graphical forms $f(t)$, XY or digital form), oscilloscope mode, measure cursors, zoom, calculations
- 
 - direction keys: choice of the parameter to modify
- 
 - « **TRIGGER** »: triggering parameter of the acquisitions (on paper, in inner memory or on file according to the current MODE)
- 
 - « **REPLAY** »: printing on screen of the acquisitions in inner memory or on file, measure cursors, zoom, calculations
- 
 - « **START/STOP** »: launch of the printing on thermal paper in DIRECT MODE on chart recorder, launch of the acquisition in any other MODE
- 
 - thermal paper-feed key for chart recorder: quick advance of the paper through continuous press
- 
 - F1 to F10 keys: choice of the parameter to modify before action on the thumb wheel

2.5. THUMB WHEEL

It makes it possible to modify the value of the selected parameter through increment / decrement. In trace visualisation $f(t)$, it also makes it possible to move the measure cursors on the screen.

2.6. LOCKING THE KEYBOARD

Simultaneously triggering the  and  keys locks the keyboard. The message « **Keyboard locked** » appears on the right top of the screen.

2.7. USE OF A MOUSE

You can use the recorder with a mouse connected on the mouse-port PS2 or on an USB connector.

You can then use it in every parts of the screen:

- directly display the configuration of a channel by clicking on its bargraph (zone 9)
- validate / invalidate a channel by clicking on its ON/OFF indication (zone 9)
- display the configuration of the logical channels (zone 7)
- validate / invalidate the logical channels with its ON/OFF indication (zone 7)
- choose one of the functions of the recorder (zone 3)
- access the help window (zone 2)
- select a parameter to modify (zone 4)
- modify the parameter selected by clicking the propositions (zone 5): right mouse-key to increment, left mouse-key to decrement or central wheel in both senses
- move the measure cursors in direct visualisation and memory output

2.8. USE OF AN EXTERNAL KEYBOARD

You can also use an external keyboard connected on the keyboard port PS2 or an USB connector.

The « ESC » key displays the main functions of the recorder.

You can then access the functions with the keys F1 to F10 of the keyboard.

The keys « Pg UP » and « Pg Down » can be used instead of the thumb wheel to increment / decrement the parameters.

2.9. UPDATING THE INTERNAL SOFTWARE

The internal software is regularly updated with its latest evolutions. This updates are available on our Internet site.

For the updating, copy the TAR file furnished to an USB key. Place it on one of the USB connectors at the rear side of the appliance.

Push the  key, then select the parameter line « **Software update** » and validate with F1 « **Modify** ».

The internal software will automatically copy the required files in the new version.

Turn off and on after the updating is complete.

2.10. USE OF THE SUPPORT LEG OF chart recorder

The support leg under the chart recorder appliance makes it possible to use it vertically with a little slant to the rear with better visual ease.



Attention: It is necessary to lock the support leg.

To do so, when in place, press strongly up on the sides in order to lock it on its support.

To close, pull on both sides at the same time.

3. INITIALISATION and PRECAUTIONS OF USE

3.1. CHART RECORDER: LOADING THE RECORDING PAPER

The paper used for chart recorder is provided with an end cut so that its loading is made easier. In case of an used roll, you'd better cut it again this way.

NOTE: Only one side of the paper is sensible to heat. Reverse it while loading would lead to no printing.

Operations to proceed:

- open the door toward you
- put the axis of the paper inside the roll
- set the axis of the paper together with the roll in place at the bottom of the receptor. The axis must be positioned inside the notches on both sides of the receptor.

The words "**ref. no.**" must appear on the left

- introduce the point of the paper into the slot on the stainless steel receptor
- collect the paper with the point above the roll under the cutter
- pull the paper sheet a few centimetres until it is well positioned
- close the table.

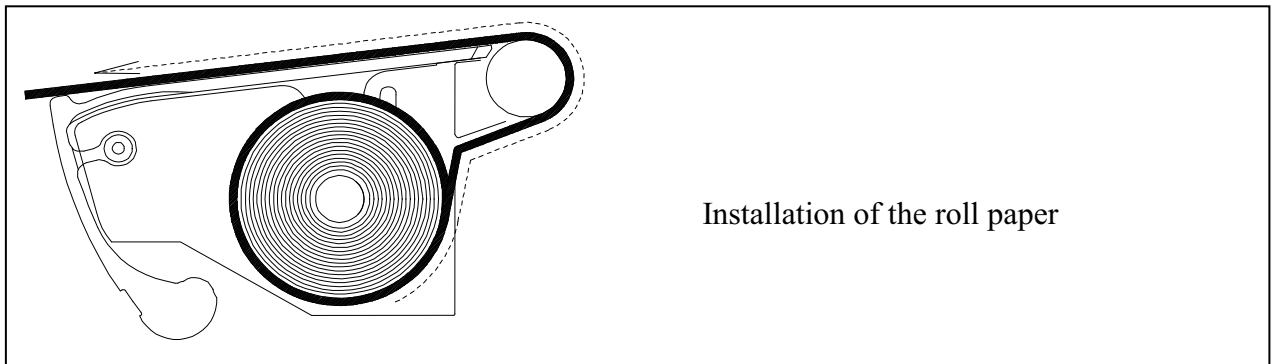

A bad loading of the paper could damage the motor and the thermal head. Special attention should be paid to it.

The recorder should always be provided with paper, for long-time direct contact with the roll will damage the thermal head.

3 – Initialisation

3.1.1. Storage precautions of the records

In order to preserve the quality of the paper records, it is advisable to abide by some handling precautions:

- never use plastic-coated pockets
- store away from light, in a dry and cool place

Paperboard-coated pockets are not advisable.

3.2. POWER SUPPLY

The recorders work with normalised mains (see chapter "technical specifications"). It has been designed for indoor use.



MAINS CONNECTION

This appliances must be connected to the mains with the cable furnished.



SECURITY

This appliances are **security class I** appliances according to the CEI1010 (NF EN 61010) classification – Security regulations for electric appliances for measure, regulation and laboratory

It also should be supplied with a one-phase network according to the **installation category II** (overvoltage category).



GROUNDING

This instruments should be grounded with the cable furnished.



Interrupting the grounding cable inside or outside the instrument is **FORBIDDEN** and makes the appliance **DANGEROUS**

3.2.1. Fuse

The protecting fuse of the mains cannot be reached by the user. In case of default of power supply, contact the after-sales service.

Type for chart recorder supply : 5 A, 20 mm quick-fuse HBC

Type for paperless recorders supply : 2,5 A, 20 mm quick-fuse HBC

3.2.2. Power up of the chart recorder

Power-up of the chart recorder is proceeded from the rear side of the appliance with the **On/Off** switch to the side marked "I".

A LED marked "ON" on the front side on the keyboard will confirm the power-up of the appliance.

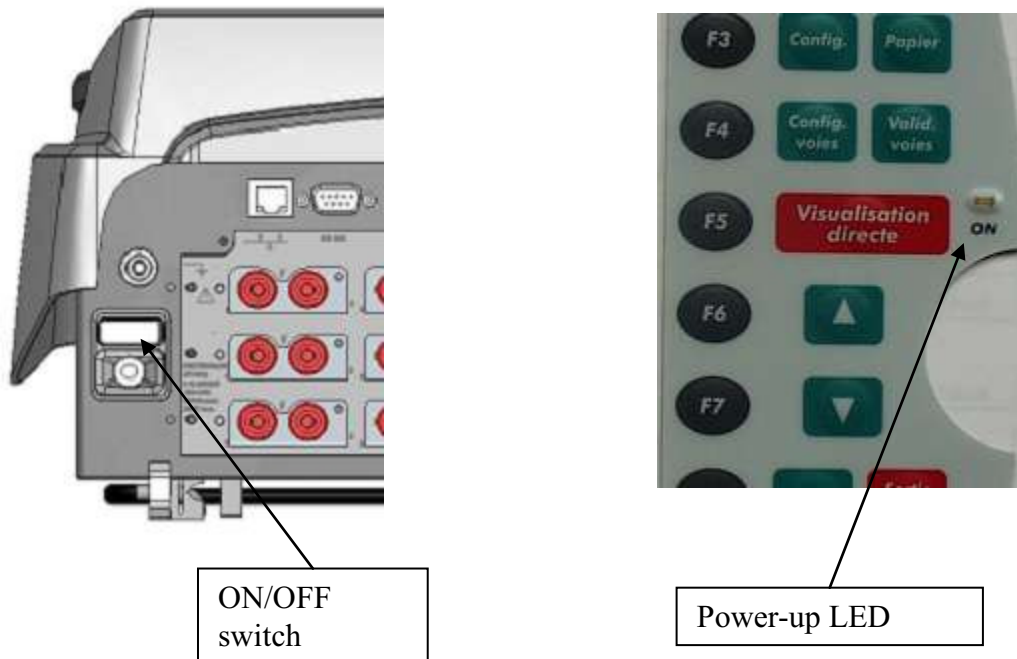

After initialisation of the internal software, the recorder will display an introducing window with:

- the version of the software: Version x.y
- the number of channels: 6 ,12, 18 or more

then enters automatically the « **DISPLAY** » mode (oscilloscope).

3 – Initialisation

3.2.3. Power up of paperless recorders

Power-up of the paperless recorders is proceeded from the right side of the appliances with the **On/Off** switch to the side marked "I".

A LED marked "ON" on the front side on the keyboard will confirm the power-up of the appliance.

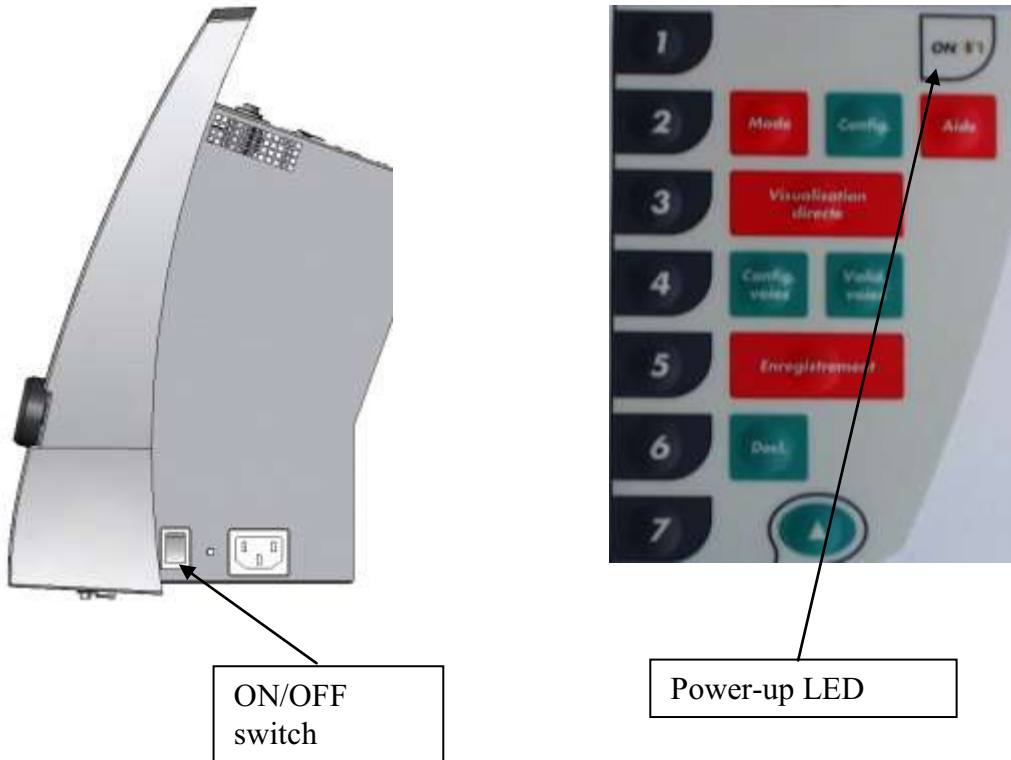

After initialisation of the internal software, the recorder will display an introducing window with:

- the version of the software: Version x.y
- the number of channels: 6 ,12, 18 or more

then enters automatically the « **DISPLAY** » mode (oscilloscope).

3.3. CONFIGURATION ON POWER-UP

On power-up, the appliances run under the latest configuration at switching-off (either normal or after power shut-down).

If figuration is run at power-up, contact the after-sales service

In case of wrong initial configuration, you can start the appliance with the default configuration :

you must press the key  until display of the initialising page.

3.4. CONNECTION TO THE MEASURE NETWORK

3.4.1. Measure of voltage

Isolated input module: the measure of voltage is made between the red and black terminals of the inputs through cables with security male single-pin plugs (according CEI 1010).

Non-isolated differential input module: the measure of voltage is made between the "+" and "-" terminals of the inputs through cables on the screw-type terminal block.

3.4.2. Measure of temperature with a thermocouple

Isolated input module: you have to measure the voltage generated by the thermocouple effect between the red and black terminals of the considered input. To ensure a right measurement, connect directly both ends of the thermocouple cable on clamping-type single-pin plugs. Connect the two single-pin plugs on the selected input in respect with the polarity.



Do not use male single-pin plugs for welding: the thermocouple effect would be altered by the weld

Non-isolated differential input module: you have to measure the voltage generated by the thermocouple effect between the "+" and "-" terminals through cables on the screw-type terminal block.

To ensure a right measurement connect directly both ends of the thermocouple cable on the selected input in respect with the polarity.

3.4.3. Measurement on bridge

Only possible with the isolated measurement bridge module

Signals of the connector

-	1
+	2
⊕	3
E-	4
S-	5
E+	6
S+	7
I+	8

- 1: Input measurement –
- 2: Input measurement +
- 3: Mass of the measurement rack (connection of the cable shielding)
- 4: - terminal of the power supply of the bridge (-1V or -2.5V)
- 5: Control of the - terminal of the power supply of the bridge (6-wire mode)
- 6: + terminal of the power supply of the bridge (+1V or +2.5V)
- 7: Control of the + terminal of the power supply of the bridge (6-wire mode)
- 8: I+ (for PT100 or PT1000)

3 – Initialisation

Connections of a complete 4-wire bridge:

Program the channel as "gauge" "complete bridge" (chapter Config. Channel)

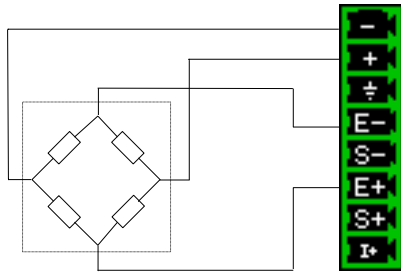

Connections of a complete 6-wire bridge:

Program the channel as "gauge" "complete bridge" (chapter Config. Channel)

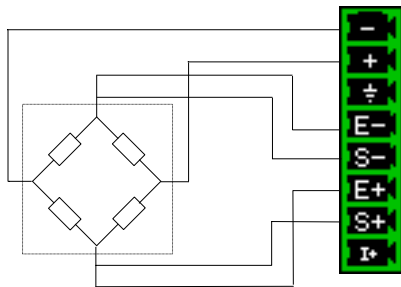

Connections of a half-bridge:

Program the channel as "gauge" "half-bridge" (chapter Config. Channel)

The other half-bridge is internal inside the appliance (two 10KΩ 0.1% 10ppm resistances)

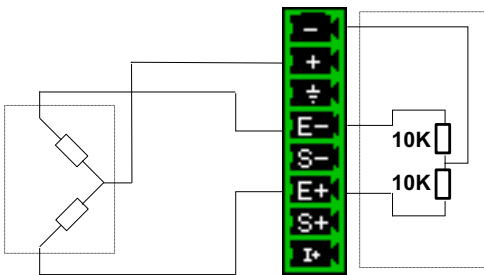

Tension measurement:

Program the channel in "tension" type (chapter Config. Channel)

Apply the measurement between « - » and « + »

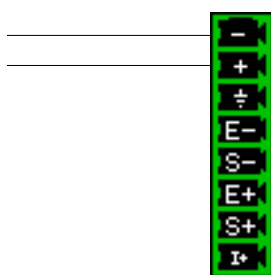

3.4.4. Measure of temperature with a PT100 or PT1000

The PT100 probe must be connected to the terminals « I+ » and « I- » (1mA current generator output). (I+ and ground for isolated measurement bridge module).

PT1000 is available only with the isolated measurement bridge module (0.1mA current generator output).

The voltage produced by the PT100 must be be measured with the terminals « + » and « - » with one of the following scheme : 2 wires, 3 wires or 4 wires. The 4 wires mounting make the measurement independent of the resistor value of the line.

2 wires wiring:

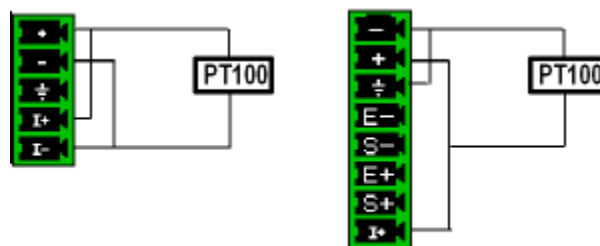

3 wires wiring:

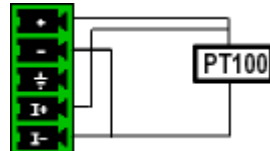

4 wires wiring:

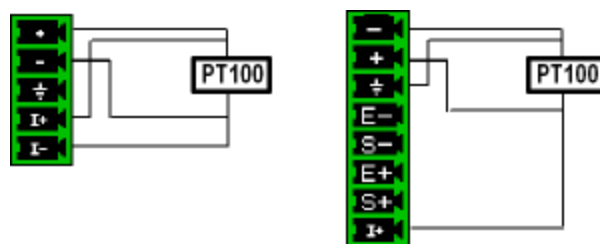

You have to choose the input channel type 2, 3 or 4 wires in the « Channel set up » function. (3 wires is unavailable with the isolated measurement bridge module).

3.4.5. Measure of intensity

Isolated input module: it is possible to measure intensities with a **shunt** between the red and black terminals of the considered input.

Non-isolated differential input module: it is possible to measure intensities with a **shunt** between the "+" and "-" terminals of the considered input.

In this case, choose the "**Current**" type among the parameters of the considered channel.

Connect the measure cables to the terminals of the shunt.

Collected results are directly displayed in Amperes or milli-Amperes according to the range of the considered channel.

3.4.6. Connection of the grounding

For measuring very small voltages, problems of spurious voltages from electromagnetic fields or common mode voltages become all the more important than the selected sensibility is higher. Thus, it is important that the outer wiring is made correctly.

Causes for such difficulties are various:

- uncertainty about the true origins of the perturbing voltages and impedances when they are generated
- uncertainty about the spurious capacitances of the circuits and wiring
- no access to the injection point of the common mode voltage of the network that provides the signal to register
- non-conformity of some appliances with the current norms
- sometimes even ignorance of the source impedances of the signal to register



YOU SHOULD ABIDE BY THE FOLLOWING INSTRUCTIONS

1/ The **mechanical ground** of every appliances should be linked to the **earth**.
The mechanical ground of the recorder is linked to the earth through the mains cable.

However, if the other appliances in the system are not equipped the same way, you'd better gather their mechanical ground with the ground of the recorder: you can access it through a union liner at the rear of the appliance.

2/ If the source of the signal to record has a **low internal impedance**, you will have to use **twisted cables**. If the **impedance is high**, you will have to use **screened cables**.

3/ When gathering the grounding from the various elements to the measure chain, you'd better check that there is no difference of potential in order to avoid any short-circuit. If there is any doubt, make a measure with a voltmeter with a low charge (1k Ω for example) between the terminals.

3.5. Routine maintenance

The ordinary maintenance is only a cleaning of the outside of the appliance. Any other operation requires qualified personnel.



Unplug the appliance before any intervention.

Do not let water flow into the appliance, in order to avoid any electrical discharge.

Regularly clean the recorder in respect with these instructions:

- use water and soap to clean the front and rear beards
- never use any product including benzine or alcohol that would damage the screen printings
- wipe with a soft non-plushy cloth
- use an anti-static product to clean the screen.

3.6. Calibration of the offsets

You can easily calibrate the inputs of the recorder for the offsets of the voltages and of the thermocouples.

To do so:

- make the instrument work for 20 minutes (outside temperature: 20 to 25°C)
- for EVERY inputs, link the "+" terminal to the "-" terminal (respectively red socket and black socket for the isolated inputs)
- validate every channels "ON"
- press the key  and select the line “ **Electronic Calibration**” and then the menu key “**Calibration Offset**”

When pressing the “**Confirm**” menu key, you will launch the calibration procedure that will last about 10 minutes.

3.7. Factory ajustement

You can easily recall the ajustement made at the factory, to repair a possible error of the calibration coefficients :

- press the key  and select the line “ **Electronic Calibration**” and then the menu key “**Reload Factory Coeff.**”

When pressing the “**Confirm**” menu key, you will reload the calibration coefficients stored at the factory.

4. USE

This chapter describes in details the actions of every keys of the front-side keyboard.

These actions are also available with a mouse or an external keyboard type PC (see chapter **Presentation**)

The details of keys and their uses are the same for all recorders.
If this is not true, the kind of recorder concerned will be written in the text.

4.1. « Mode » key



Choice of the functioning mode of the recorder:

- ➔ **DIRECT** mode: real-time paper-printing of the measured signals (**chart recorder only**)
 - use: immediate writing on paper, long-term slow acquisition
 - possibilities: complex triggering of the writing, action after the end of the writing, simultaneous recording in internal memory or on a file
- ➔ **MEMORY** mode: fast acquisition in internal memory of the measured signals
 - use: short-term fast acquisition (transitory)
 - possibilities: complex triggering of the writing, action after the end of the writing, simultaneous recording on file
- ➔ **GO-NOGO** mode: fast acquisition in internal memory of the measured signals
 - use: short-term fast acquisition (transitory) for capture of non repetitive events
 - possibilities: complex triggering, particularly on overrun of a pre-recorded frame 12from a channel, action after the end of the writing, simultaneous recording on file
- ➔ **FILE** mode: fast record on internal hard disk or USB key of the measured signals
 - use: long-term fast acquisition (only limited by the size of the memory)
 - possibilities: complex triggering, action after the end of the writing, very big amount of data of acquisition
- ➔ **POWER ANALYSER** mode : It makes it possible to measure powers and harmonics. Measured values can be tracked in real time or recorded.

4.2. « Help » key



Displays a help window or the user's notice.

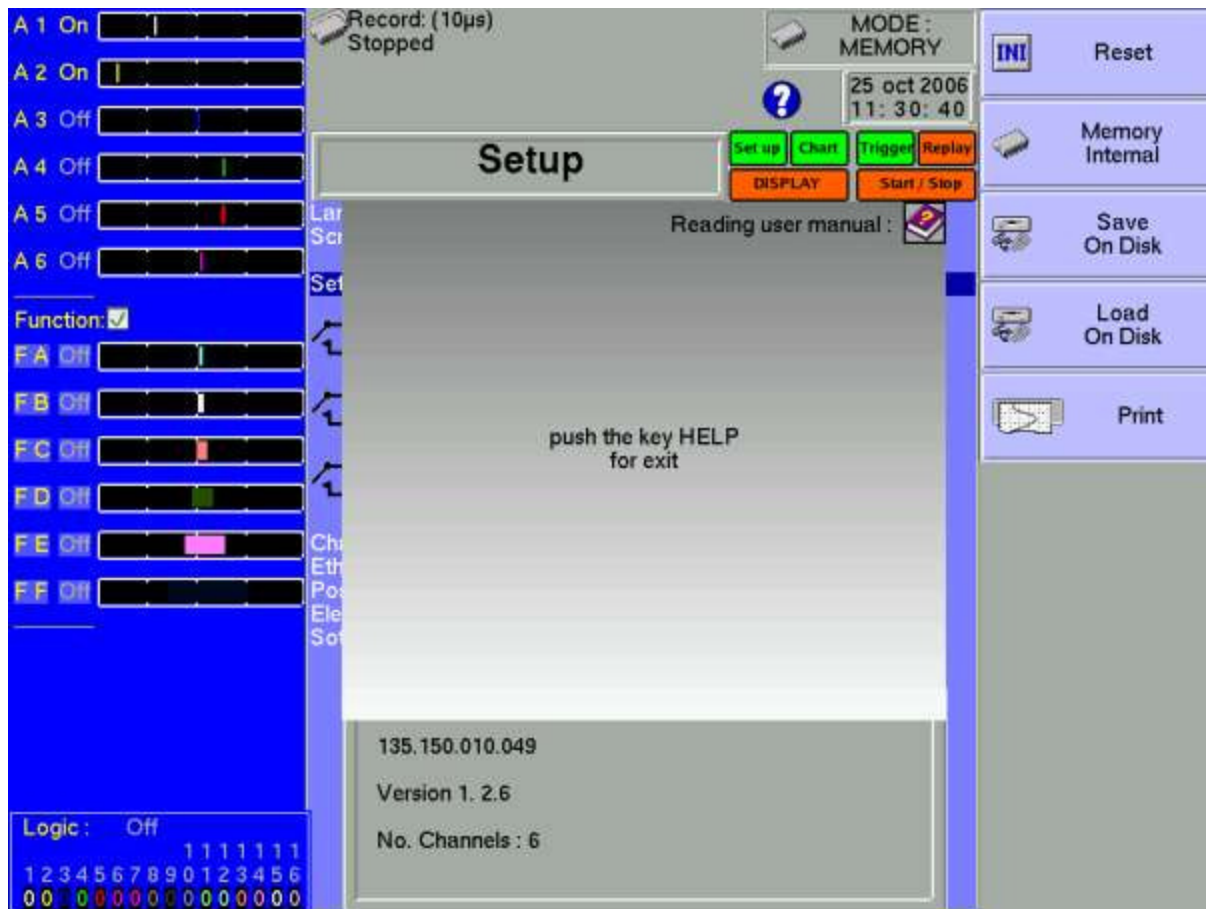

After pressing « **Help** », pressing any other key will display the help associated with it.

Press the « **Help** » key again to exit.

If a mouse is connected to the recorder, you can also display the user's notice (requires an integrated PDF-reader, cannot be used without a mouse).

4.3. « Set up » key



General configuration of the appliance, control of the alarm outputs, TCP/IP network address, calibration of the channels, updating of the internal software.

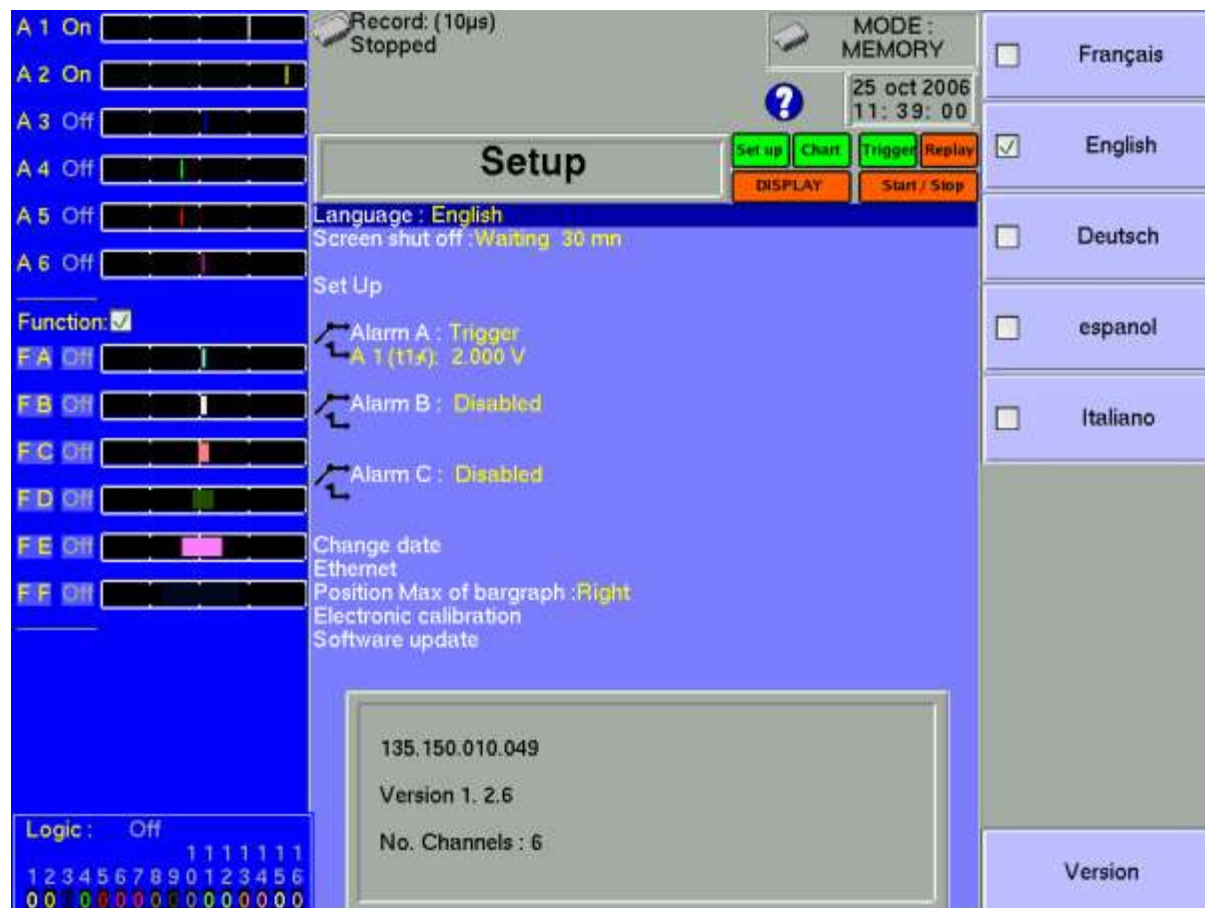

- **Language:** choice of the language used by the appliance
- **Screen shut-off:** turns off the back-lighting of the LCD screen, adjustment of the delay
- **Configuration:** initialisation of the appliance in its default configuration, saving / loading in internal ROM memory, on internal hard disk or USB key, thermal paper printing

ATTENTION: you will loose the current configuration

- **Alarm A:** use of the A alarm output (relay contact)
 - **Without:** no condition is controlling the contact; it remains always open
 - **Trigger:** control by association of the analogical or logical channels on several thresholds (cf. chapter Triggering)
 - **Paper error:** control by lack of paper or opening of the door of the printing block (**chart recorder only**)

In any case, the contact is **open** if the condition is **true**.

- **Alarm B:** use of the B alarm output (logical 0-5V output)

4 – Use

- **Without:** no condition is controlling the output; it remains always low (0V)
- **Trigger:** control by association of the analogical or logical channels on several thresholds (cf. chapter Triggering)
- **Paper error:** control by lack of paper or opening of the door of the printing block (**chart recorder only**)

In any case, the output is **low (0V)** if the condition is **true**.

- ➔ **Alarm C:** id. Alarm B
- ➔ **Date modification:** setting the hour and date for the appliance (for NTP see 16.1.2)
- ➔ **Ethernet/Option:** modification of the TCP/IP address , validity of USB2 (option).
- ➔ **Position Max of bargraph :** moving direction of the bargraph of each channel on the screen
 - **Right :** maximum value of the channel on the right
 - **Left :** maximum value of the channel on the left
- ➔ **Electrical adjustment:** calibration of the offsets of the channels, return to the factory adjustments
- ➔ **Software update:** updating of the internal software (see chapter Presentation)

The window at the bottom of the screen shows:

- The current TCP/IP address
- The number of the current version of the internal software
- The number of detected channels

4.4. « Chart » key

Chart recorder only.

Definition of every characteristics of the paper printing.

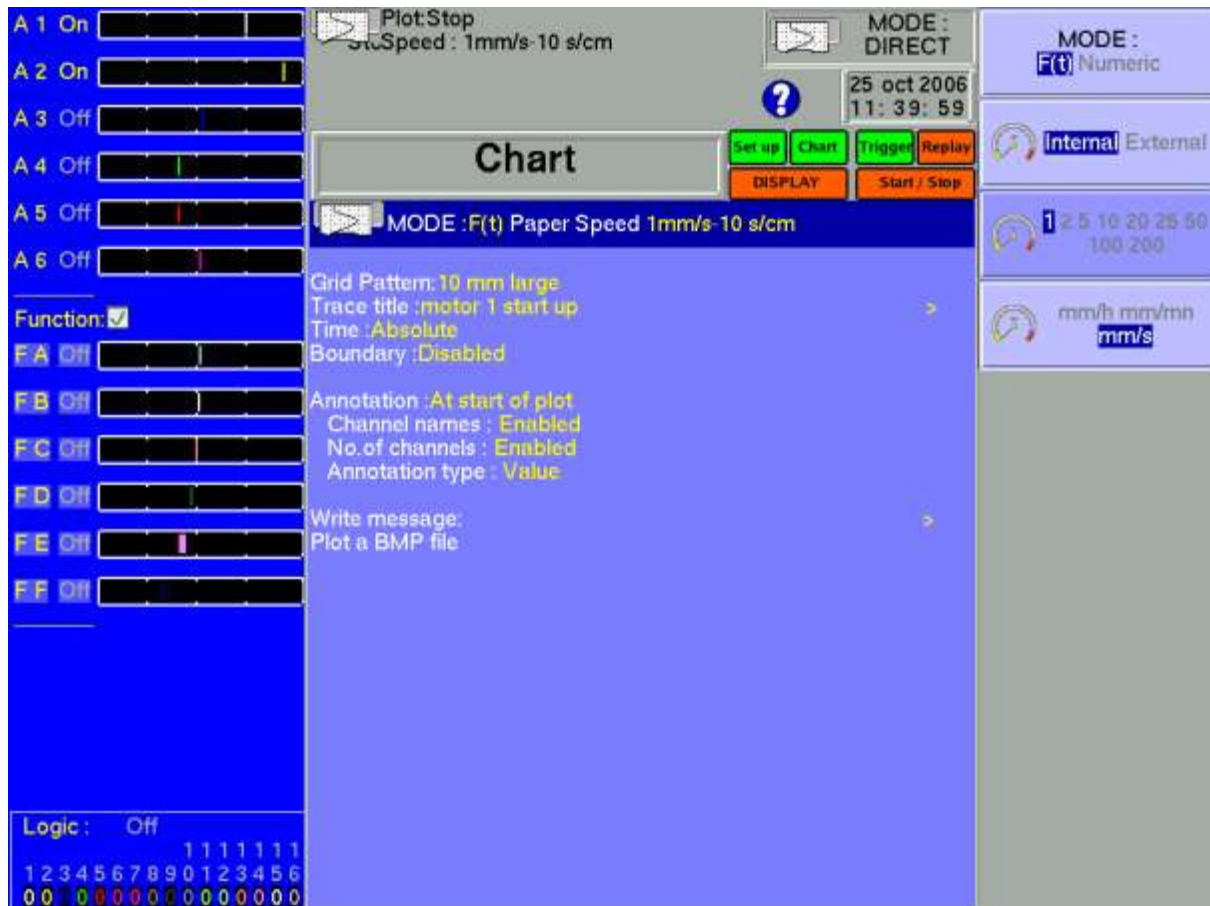

See chapter **Direct mode** for a description in details of the parameters on this page.

4.5. « Channels set up» key

Channel
set up

Configuration of the channels. After pressing this key, select a module, then select a channel to access its parameters.

4.5.1. Analogical channels

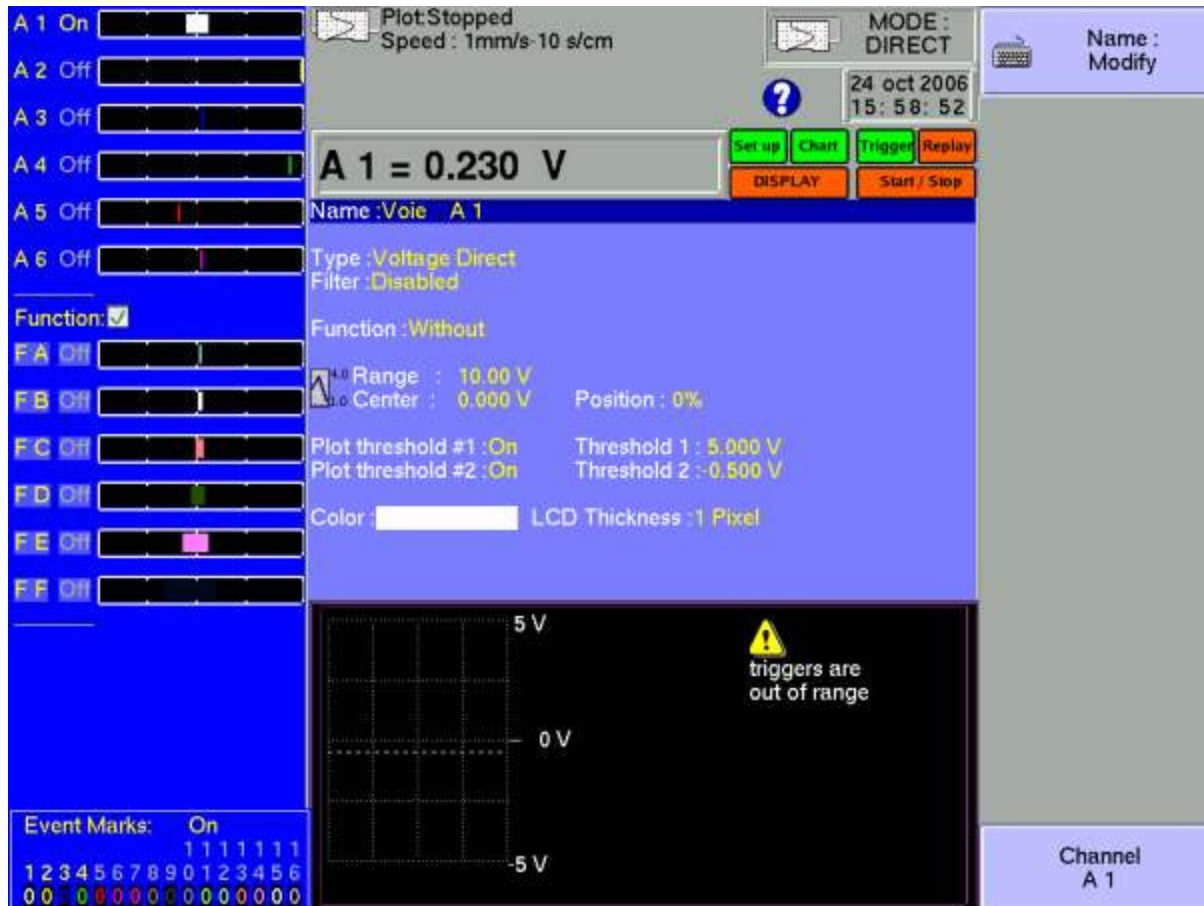

→ **Name:** give a name to the channel (max. 26 characters)

→ **Type:** choice of the type of measure made on this input

For an isolated measurement module

- tension, intensity, thermocouple, Frequency, Counter
- direct, RMS, derived or integral
- value of the shunt, in current measurement
- selection of the type in thermocouple, compensation, unit

For an multiplexed module

- tension, intensity, thermocouple, PT100
- direct, RMS, derived or integral
- value of the shunt, in current measurement
- selection of the type in thermocouple, compensation, unit
- PT100 4,3 or 2 wires.

For an isolated measurement bridge module

- tension, intensity, thermocouple, Gauge
 - direct, RMS, derived or integral
 - PT100 /PT1000 2 or 4 wires.
 - value of the shunt, in current measurement
 - selection of the type in thermocouple, compensation, unit
 - tension of the measurement bridge 2V or 5V
 - complete bridge or half-bridge
 - reset of the measurement bridge (zeroing)
 - coefficient of the gauge
- Derived or integral input: The user shall select an integration time according to the filtered signal (this integration time will be the same for every channels) and a filter for the signal. In integral mode, a reset enables the zeroing of every channel.

→ **Filter:** positioning a filter at the inlet

- 10 kHz, 1 kHz, 100 Hz, 10 Hz for analogical filters
- 1 Hz, 10 s, 100 s or 1000 s for digital filters

→ **Function:** makes it possible to assign a mathematical calculation function to the considered channel

- **Without:** no function.
- **Change unit:** modifies the unit of the measures on the channel; you can then program a couple of dots X1, Y1 and X2, Y2 to achieve a scaling
- **Calculation:** available mathematical functions, associated parameters and unit

→ **Range and Zero:** setting the range and the zero of the channel

The range is the measure that corresponds with the total width of the screen on which the channel is printed.

The zero (or centre, or offset) is the central value of the measure.

You can settle precisely the value of the range and of the zero, so that you can take full benefit of the whole width of the screen or paper output.

The « **Reset Zero** » key allows you to fix the zero in the middle of the range (analogical zero).

NOTE: When using a mathematical function or a scaling, the zero matches the zero in the requested unit.

→ **Position:** position of the zero in the screen or on the paper, from 0 up to 100%

The lower part of the LCD screen shows you the min. and max. possible values (limits) of the measure, and the position of the zero.

A warning message is displayed on the right when the programmed analogical thresholds are out the possible measurement range.

→ **Threshold 1:** visualisation of the position of the triggering threshold #1 on screen or on paper

→ **Threshold 2:** id. for threshold #2

4 – Use

- **Colour:** allows you to modify the colour of the printing on screen
- **LCD Thickness:** settles the thickness of the printing of the measure on the LCD screen and on the thermal paper, from 1 up to 8 pixels

4.5.2. Function between channels

It is possible to add until 6 news channels . These new functions channels are calculated between two channels or 2 functions . The operators are +,-,*,/.

All the possibility of channels (range , colour etc...) are available for these channels

4.5.3. Logic channels



- **Change logic channels:** choice of the colour and of the name of the channel on screen
- **Valid Event Markers:** validation of the acquisition and of the printing of the logical channels
- **Number of markers:** choice of the number of logical channels, from 1 up to 16
- **Height Mark.:** size of the display and printing zone of the channels on the paper
- **Position Mark.:** position of the logical channels on the screen and on the paper

4.6. « Channel on/off» key



Choice of the channels displayed on screen, printed on paper or recorded in memory or on file.



After pressing this key, choose the inlet card (module) concerned with F1 (1st key on the right of the screen) and select the channels you want to display on the screen, print on paper or record in internal memory or on file.

Proceed the same way to validate the functions between channels (they are considered as supplementary channels).

4.7. « Display » key



Real-time visualisation of the measures on the LCD screen in 1000 dots.

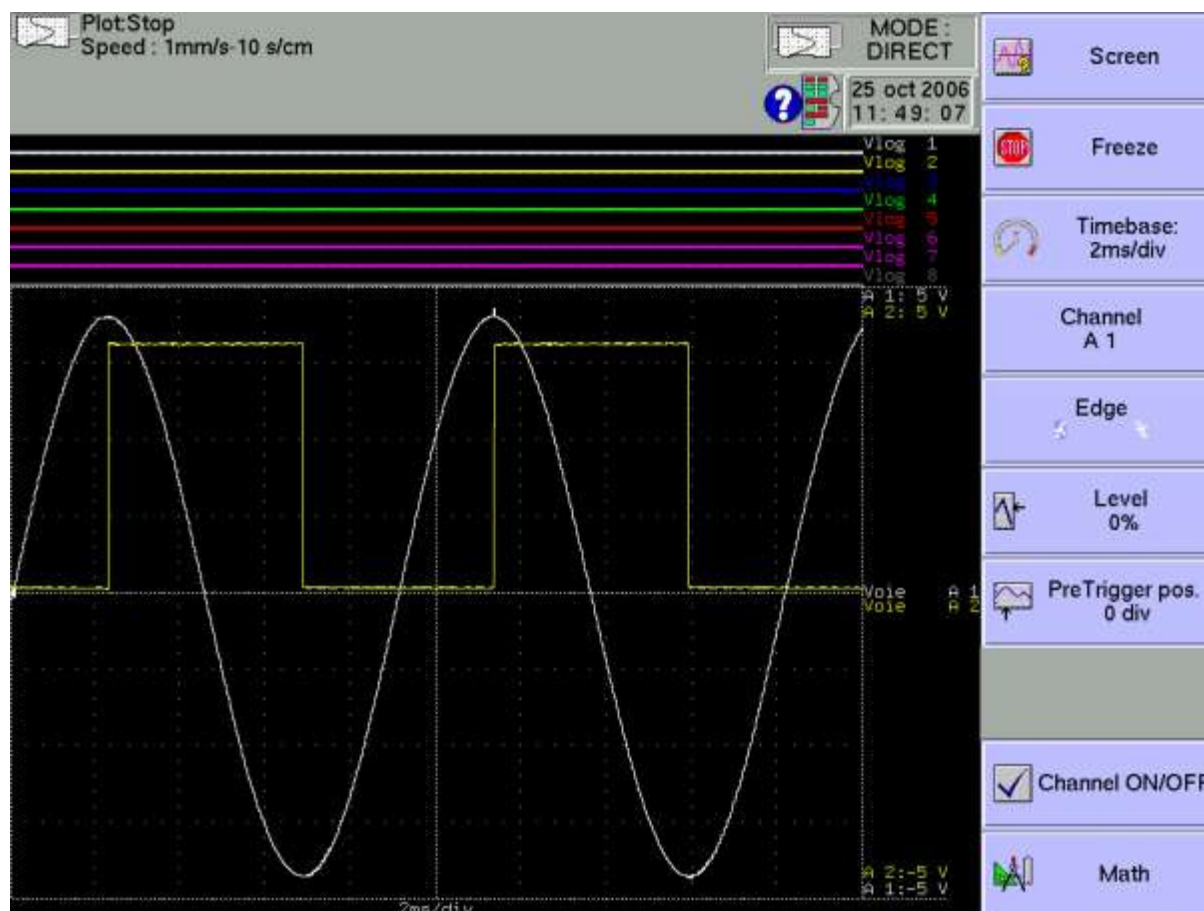

- ➔ **Screen:** configuration of the display of measures on screen
 - graphics **F(t)**, graphics **XY** or **digital** display of the measures
 - **Full screen** display of the measures only
 - **Modifications diagrams** to organise the display on screen (see chapter **Diagrams**)
 - **Colour** to customize the colours on the screen
 - **vertical** or **horizontal** sweep on screen
 - display of the **nouns** and **limits** (min-max) of each channel.

4.7.1. Display F(t) (oscilloscope mode)

The **F(t)** display mode allows real-time visualisation of the validated channels on screen, measures with cursors, adding automatic amplitude and time measurements, then saving into files or printing on paper of the acquisition after stop.

- ➔ **Stop:** freezes the measures on screen in order to achieve measurements with cursors, calculations, savings or printings of the measures on screen (1000 dots) in **F(t)** mode.

You will then have access to:

- **Restart** – to restart the sweep

- **Time cursors** – to display the vertical cursors (2) in order to make measures in the display; move the cursors by selecting 1 or 2 then turning the thumb wheel, or click on the cursor with the mouse if it is connected
- **Voltage cursors** – to display the horizontal cursors (2) to make amplitude measures on the display; proceed as for the time cursors to move them. You can also change the range / zero to expand and move your measure on the screen.

→ **Time base:** changes the base of the sweeping time of the F(t) display, from 100 μ s/div up to 10ms/div; each division includes 100 dots, i.e. a sampling frequency from 1 Msample/s (1 μ s) up to 0.16 sample/s (6 s).

For the chart recorder (direct mode) you can use the same time base for screen then for chart. The full screen (1000 samples) correspond to 62.5 mm of paper.



In F(t) mode (oscilloscope mode), the sweeping is in « triggered » mode for time bases < 100 ms/div, and in « scrolling » mode above.

In « triggered » mode, the 4 following parameters set the trigger of the displayed acquisition. These parameters are not available in « scrolling » mode:

- **Choice:** choice of the triggering channel
- **Front:** active front of triggering
- **Level:** vertical position of the trigger between -100% and +100%
- **Position Decl.:** horizontal position of the trigger between 0 and 10 divisions

In « triggered » mode, the position of the trigger is marked with a small triangle on the selected channel.

- **Validation:** choice of the displayed channels on screen; identical as the main key « Valid. channels »
- **Calculation Math.:** adding automatic measurements on screen; click « **Add** » to add a measure on the screen and « **Delete** » to delete one; see chapter « **Mathematical calculations** ».
 - # **Param:** choice of the measure for modification
 - **Channel:** choice of the channel on which you will assign the measurement
 - **Type of function:** **Amplitude** for amplitude measurements, **Time** for time measurements or **Calculation** for measurements of average values and effective values RMS

4.7.2. Display XY

The **XY** display mode allows you to display the validated channels in real time on screen, one versus the others.

One of the channels defines the extension on the horizontal axis; the other channels define the dots on the vertical axis.

→ **Grid pattern:** to customise the grid pattern of the XY display

You can select, either a predefined grid pattern with selection of the colour, either a customised grid pattern (copied from an USB key or ftp to the hard disk)

This BMP file size is 640*640 pixels with 24 colours, the predefined grid (gridxy.bmp) is in the base directory of the hard disk.



You can use “paint” (from Microsoft) or a free software (paint.NET, gimp word etc..) to create the BMP file.

With paint software, to create a line you must give the two points coordinates. These coordinates are displayed on bottom left corner of the window.

→ **Point or vector:** display the point or the line between successive points .If the channel frequency is higher than the display point frequency (0.1Hz) you can have a false display

→ **X channel:** choice of the channel on the horizontal axis (sweep)

→ **Y channel:**

→ **One:** only one channel on the vertical axis; the choice of this channel is made on the next soft key

→ **Several:** Several channel on the vertical axis; the choice of these several channels is made on the next soft key

4.7.3. Digital display

The **Digital** display mode allows you to display the digital values of the validated channels in real time on the screen.

No action is possible in this mode.

4.8. Direction keys



They move the reverse video zone on to the parameter to modify.

You can modify the parameters with the thumb wheel, with a mouse if it is connected, or with an external keyboard.

4.9. « Trigger » key



Programming the start and stop conditions of the paper printing in chart recorder Direct mode, the acquisition of the channels in Memory, File and GoNogo modes.

Choice of the actions after acquisition or printing and validation of the saving in real time.



The programming of the triggers is different according to the current mode (Direct, Memory, GoNogo or File).

See the chapter corresponding with the current mode for a more detailed description.

4.10. « Replay » key



Display on screen of the acquisitions available in internal memory or in files on hard disk or USB key.

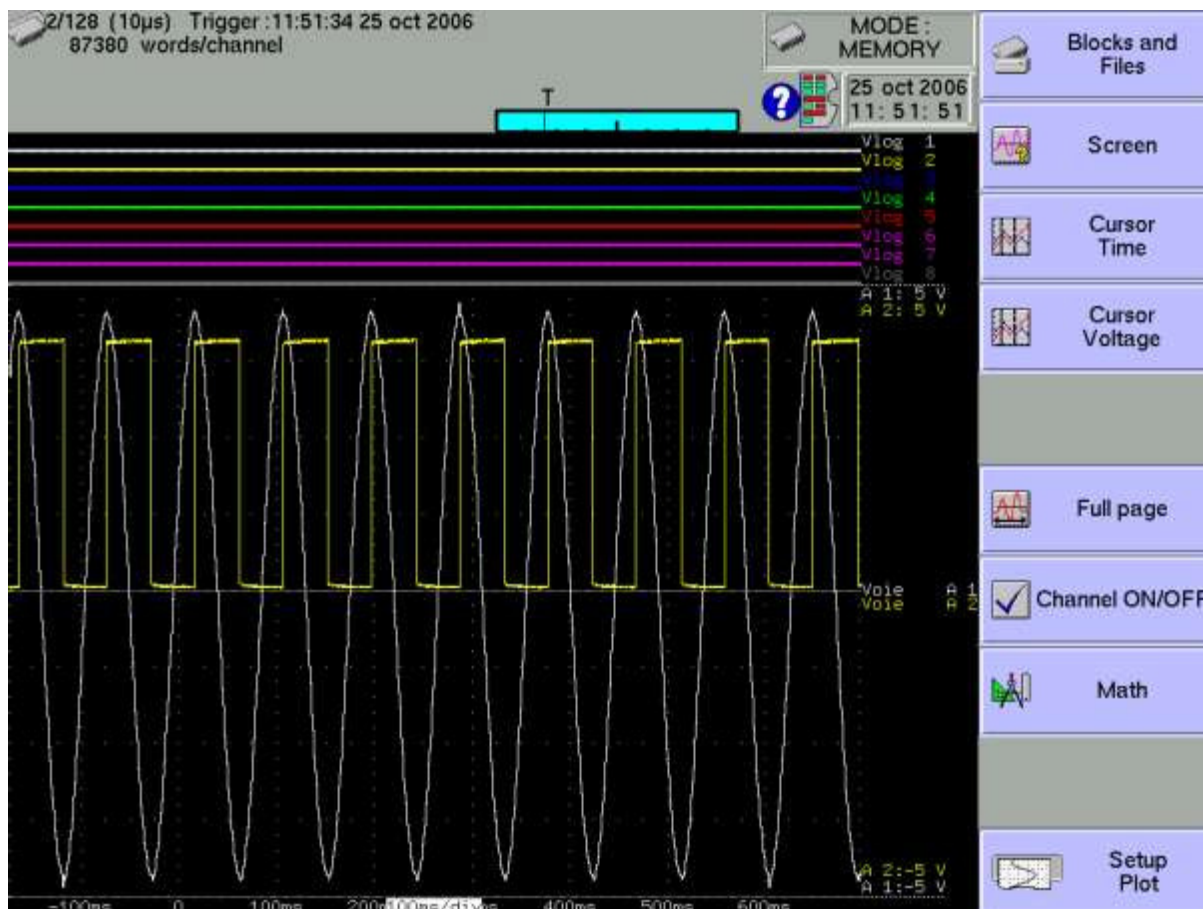

This function has the same commands as the « **Display** » function.

The only difference is the « **Blocks and Files** » command that allows you to select the memory block (zone in the internal memory divided in blocks) or the file to display.

→ **Blocks and Files:**

- **Number block:** number of the memory block to display
- **Load file:** choice of the file to display
- **Load configuration:** copy of the configuration of the acquisition being displayed into the current configuration (validated channels, ranges...)
- **Save Disk:** saving the current display into a file
- **Reference:** comparison of blocks versus a reference block (Memory mode); the traces of the reference block are shown in dots



When the size of the acquisition to display is big, collecting and displaying the dots may be long.

4 – Use

Displaying is then achieved in 2 phases:

- a quick phase that displays the envelope of the acquisition: some dots may not appear
- a phase where all the dots of the acquisition are displayed: an assessment of the percentage of advance is displayed at the bottom of the screen.

4.11. « Start/Stop » key



Start / Stop

This key has various effects according to the current mode of the appliance.

- ➔ **Chart recorder Direct** mode: launches the printing on paper if its triggering is in manual start; else, sets the appliance in wait mode for the triggering **Start** condition.
- ➔ **Memory** mode: launches the acquisition in internal memory and sets the appliance in wait mode for the triggering **Start** condition.
- ➔ **GoNogo** mode: launches the acquisition in internal memory and sets the appliance in wait mode for the triggering **Start** condition.
- ➔ **File** mode: launches the acquisition on file and sets the appliance in wait mode for the triggering **Start** condition.

In any case, to stop recording before the triggering **Stop** condition, you only have to press the same key « **Start/Stop** » once again.



In **Memory**, **GoNogo** or **File** modes, the appliances switches automatically to display of the current acquisition.

At the top left of the screen, it will then appear:

- the number of the current block if required
- the current sampling rate
- the status of the acquisition (waiting triggering start, proceed xx%, ...)
- the opening of a saving file if required
- a bargraph where you can recognise the percentage of achieved acquisition and the percentage of displayed acquisition.

4.12. Paper-feed key

Chart recorder paper-feed as long as you press the key.

4.13. Screen copy

You can copy the screen in a bmp file : press simultaneously keys



A BMP file will be create on the USB key (if available) or on the hard disk.

The name of files will be BMPxxxxxx.bmp and will be saved in the folder DD/FolderBMP.

You can copy this folder on a USB key or delete it.

You can also copy and delete this folder with your pc with ftp.

5. DIAGRAMS

Diagrams are the partition of the screen or of the width of the paper sheets in zones of printing or displaying in order to gather or separate channels and improve the legibility of the acquisitions.

You can access this configuration with the « **Modification Diagrams** » key from:

- « **Paper** » key, parameter « **Reticule** »
- « **Direct visualisation** » key, parameter « **Screen** »
- « **Memory output** », parameter « **Screen** »

The appliance switches automatically to « **Direct visualisation** » to show you your organisation:

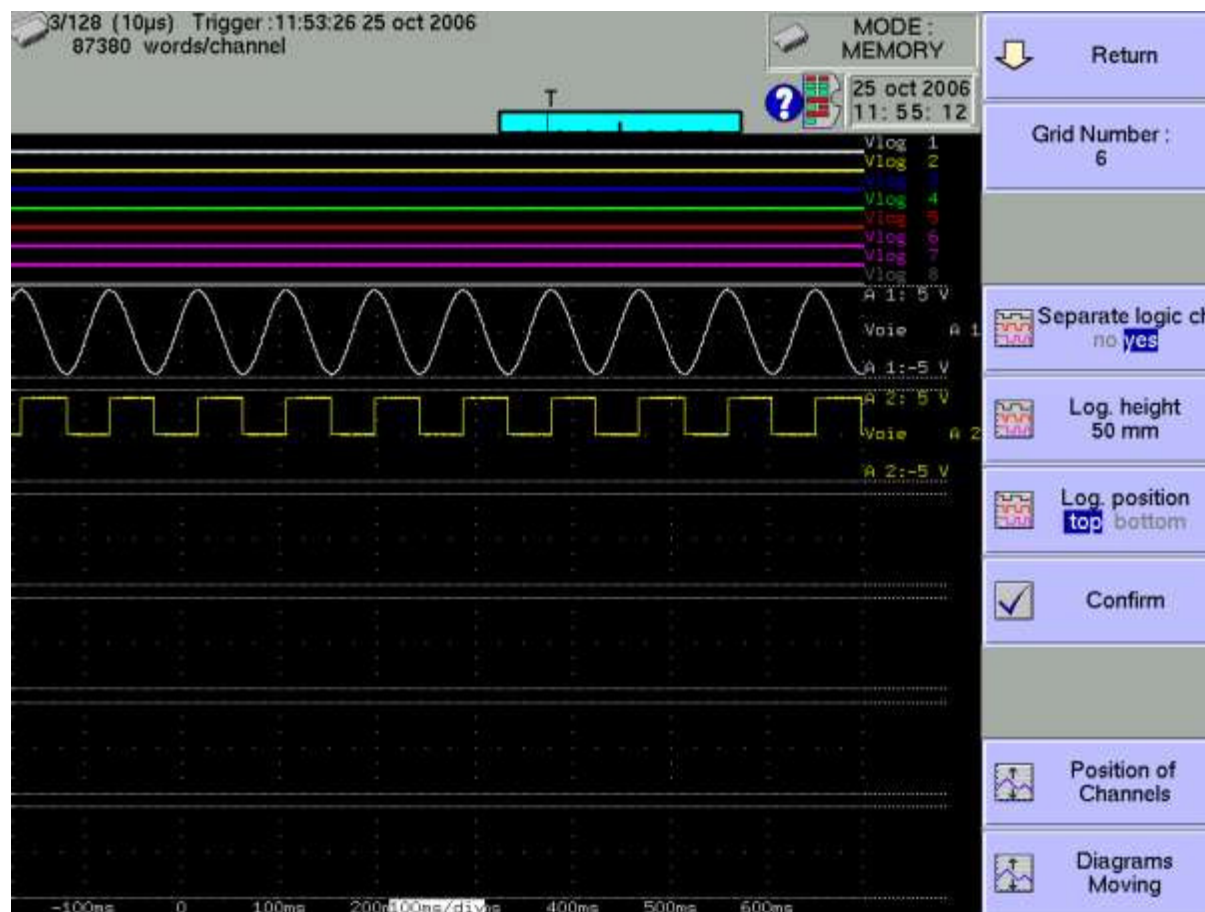

- ➔ **Number Diagram:** number of divisions of the screen or of the paper up to maximum 12
- ➔ **V.Log separated:** prints or displays of the logical channels superimposed to the diagrams or in a separate diagram
- ➔ **Height V.Log:** size for displaying the logical channels, from 3 up to 250 mm
- ➔ **Position V.Log:** position of the display of the logical channels above or below the diagrams of the analogical channels

5 – Diagrams

- ➔ **Validate:** validation of the previous parameters (Number diagrams, height and position of the logical channels) in order to take the modifications into account
- ➔ **Position of the channels:** place of the channels in the diagrams; select the channel you want and press the arrows to move it
- ➔ **Change Diagrams:** modification of the size of each diagram; select the channel you want and enter its start and height in mm.



Don't forget to validate your modifications to have them taken into account



After selection of the number of diagrams or validation of the logical channels, press « **Validate** »; the appliance dispatches the diagrams on the screen (and also on the paper) automatically in equal sizes

5.1. Positions of the channels

Press the « **Position of the channels** » key to dispatch the channels in the diagrams.

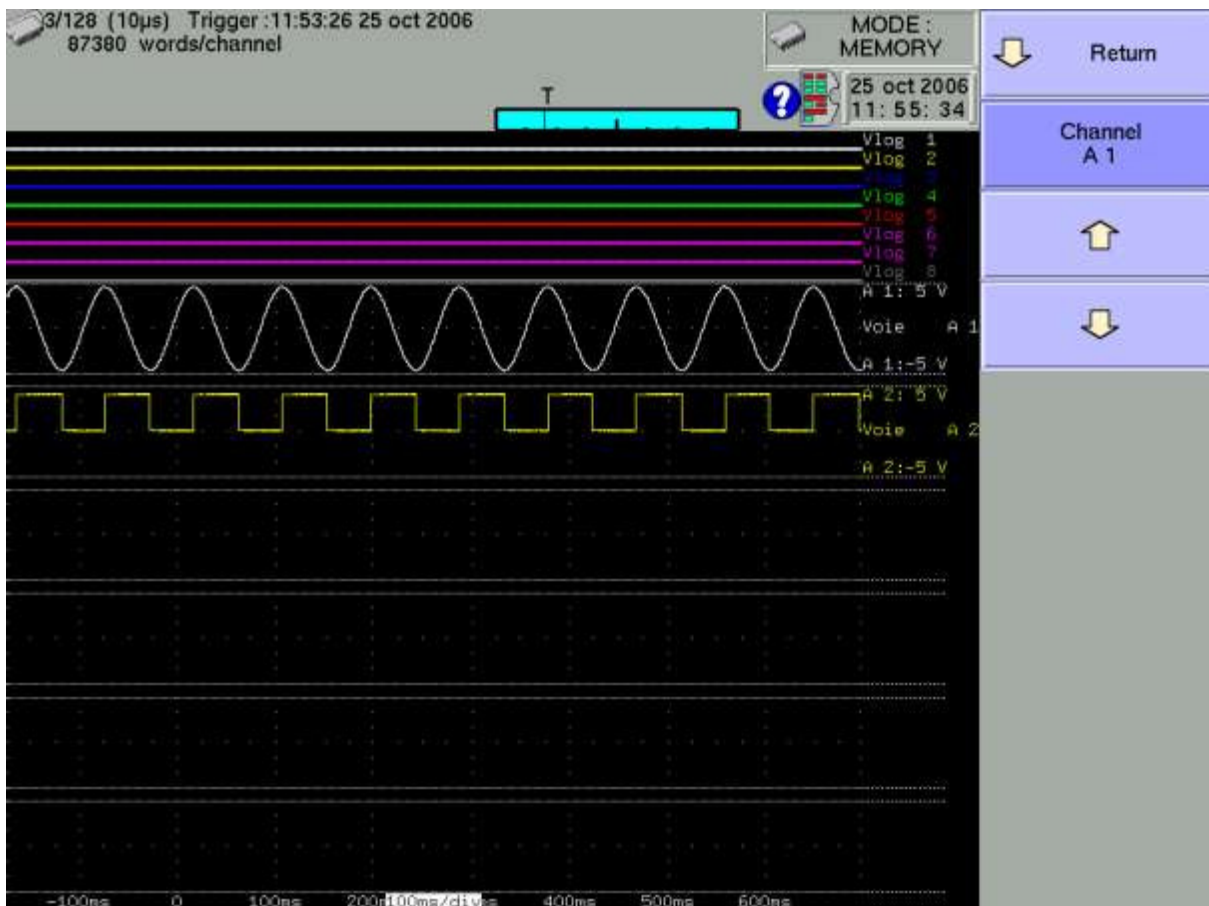

Select the channel to move, then use the 2 arrows to move it upward or downward.

5.2. Change diagrams

Press the « **Change Diagrams** » key to change the size of each diagram.

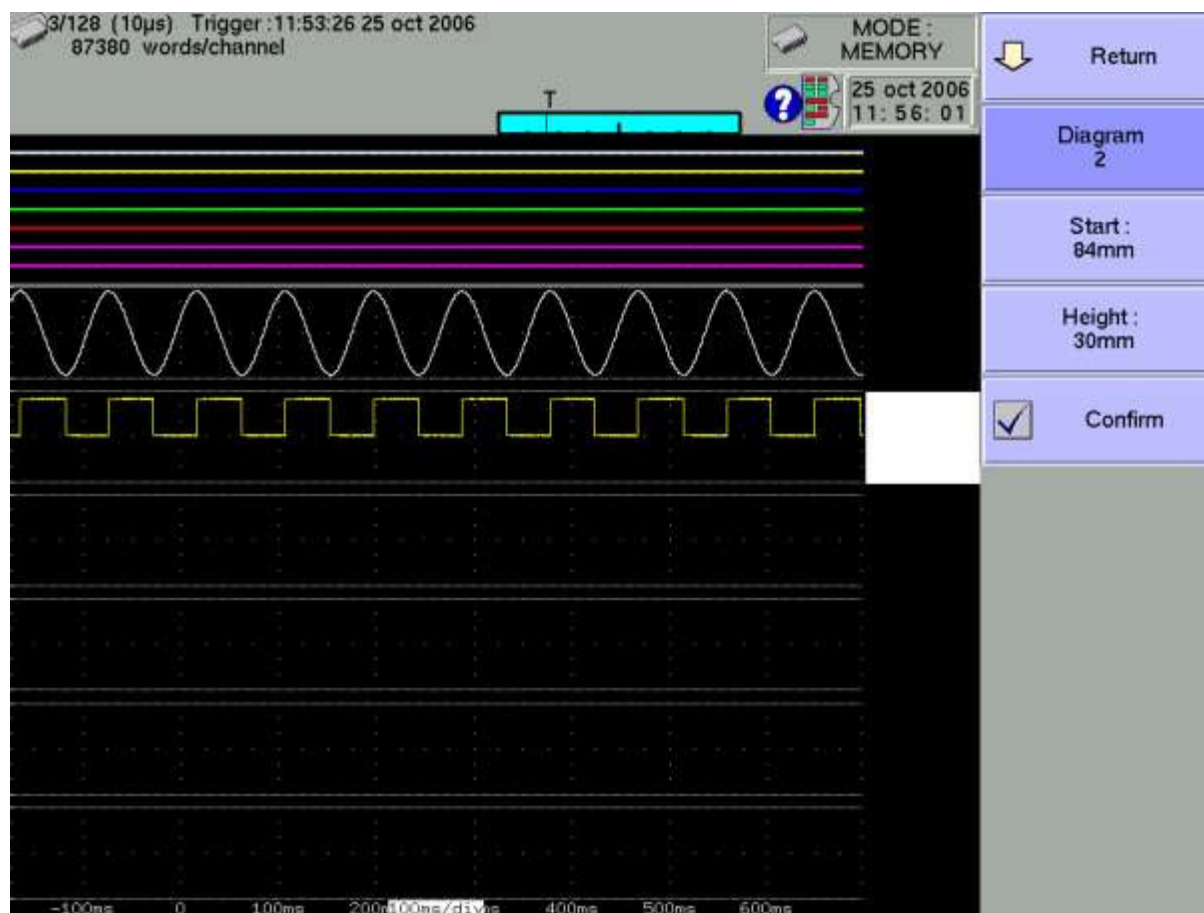

Select the diagram to change, then adjust its position with « **Start** » and its size with « **Height** ».



Don't forget to validate your modifications to have them taken into account

6. TRIGGERS

This chapter describes the triggers available in this appliance.

They are used by:

- « **Set up** » key, parameters « **Alarm A, B and C** »
- « **Trigger** » key, parameters « **Start** » and « **Stop** »

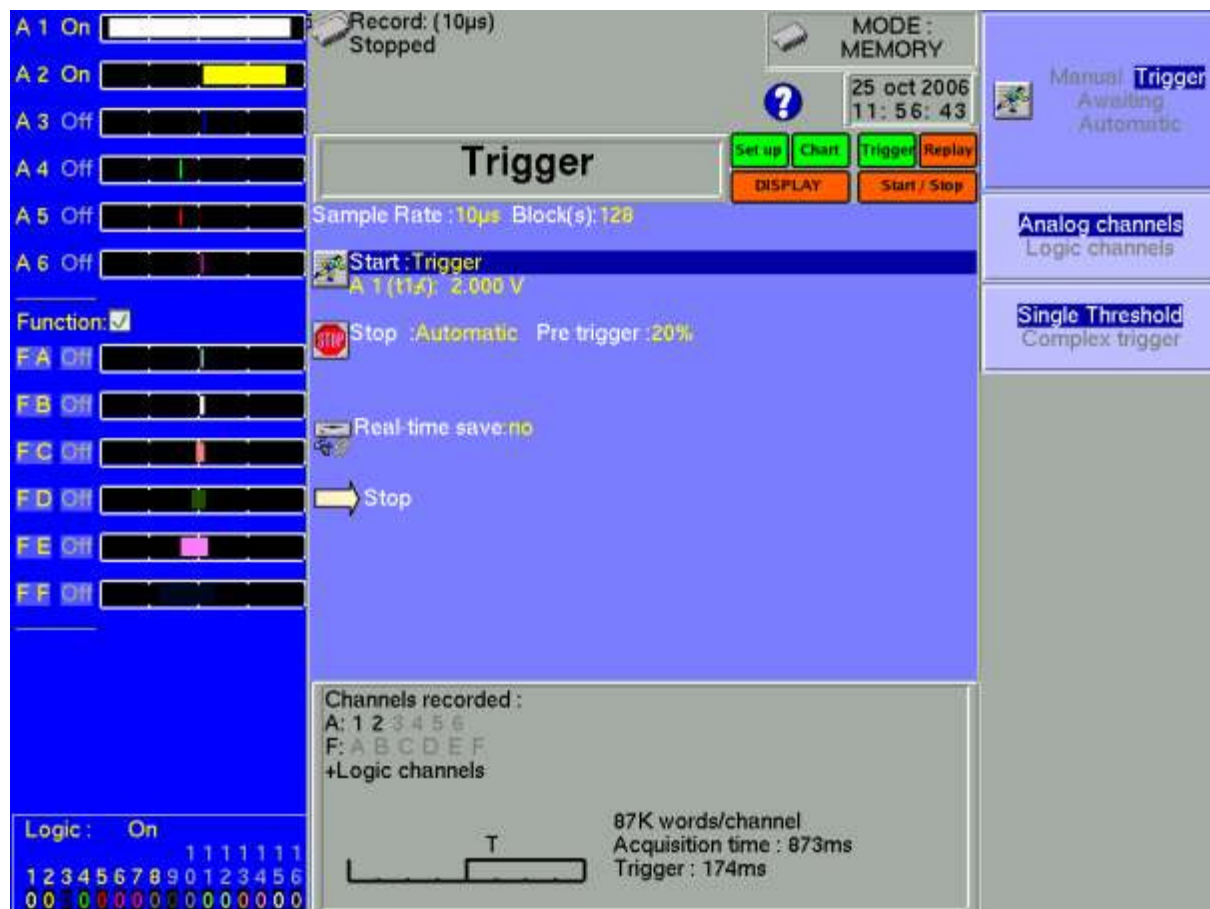

➔ **Trigger Edge/Level** : Edge :you must have the real transition of the threshold

➔ **Analogical / Logical channels**: triggering from analogical or logical channels (event marks)

➔ **Single / Several thresholds**:

- triggering from only one channel and only one threshold
- or complex triggering from several channels and several thresholds; see description below.

This complex triggering is only possible with analogical channels.

6.1. Triggering with analogical channels

After selection of the triggering with analogical channels, the following line on screen will allow you to set parameters for the triggering start condition. It will depend on the selection of only one threshold or of several thresholds.

6.1.1. Single threshold

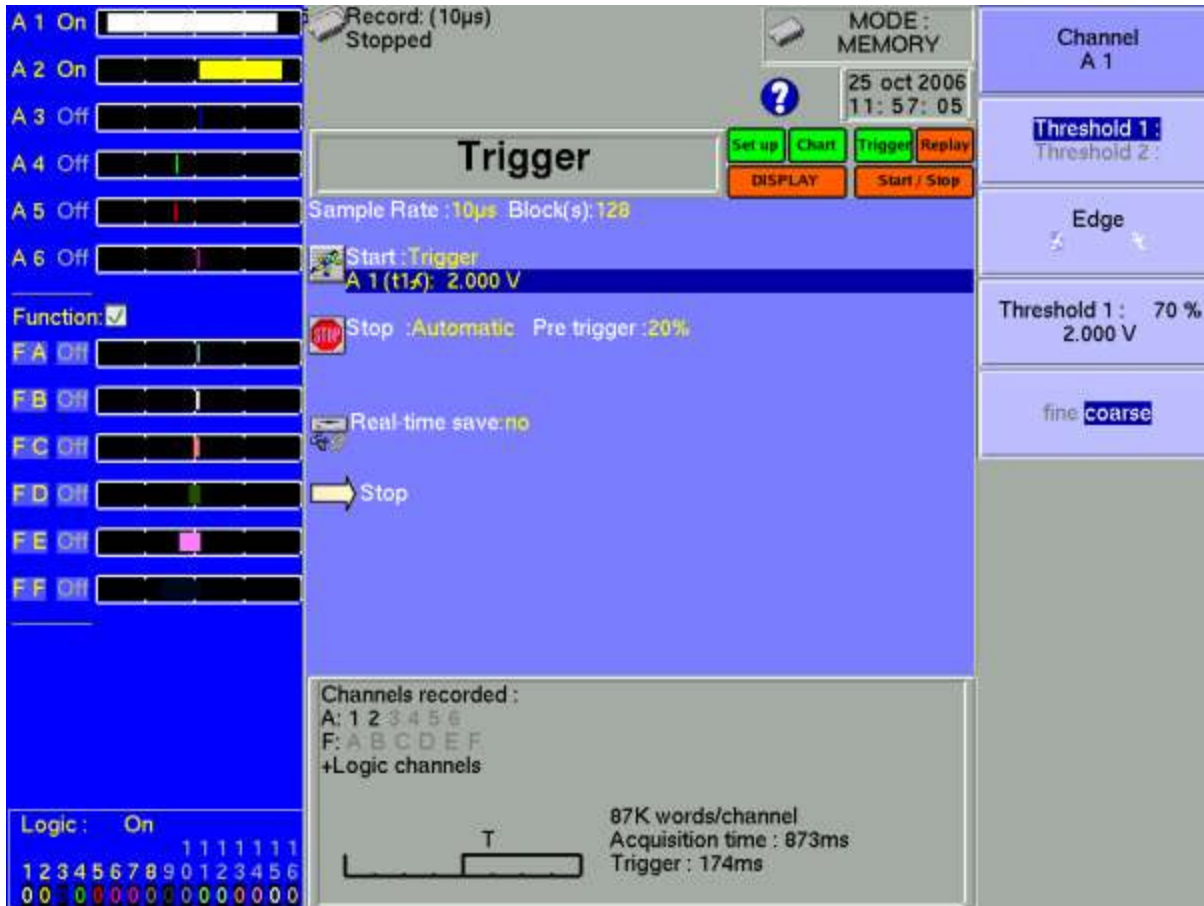

- ➔ **Channel:** selection of the channel on which the triggering start threshold is assigned
- ➔ **Threshold 1 / Threshold 2:** selection of the threshold to parameter; each channel is tested with two thresholds. You can, for example, program a start condition on the channel A1 and the Threshold 1, and a stop condition on the same channel A1 and the Threshold 2.
- ➔ **Front:** selection of the active front for the threshold
For example, the condition A1 (s1 ▲): 0.000 V becomes TRUE when the channel A1 turns higher than 0V.
- ➔ **Threshold value:** value of the selected threshold in percentage and true value (taking into account the current unit and scale in the configuration of the selected channel)
- ➔ **Fine / Coarse:** selection of the fine or coarse setting of the selected threshold

6.1.2. Several thresholds

After selection of a trigger on several channels and thresholds, a « Call » key allows you to program the condition for a complex trigger.



- ➔ **One of Thresholds (or):** the first conditions achieved validates the trigger
- ➔ **All Thresholds (and):** every conditions must be achieved simultaneously to validate the trigger
- ➔ **Slope (or):** triggering according to the slope of the signals; the first condition achieved validates the trigger

You will then be able to add, delete or modify any condition of the trigger by selecting one of the conditions.

6 – Triggers

6.1.3. Trigger according to thresholds

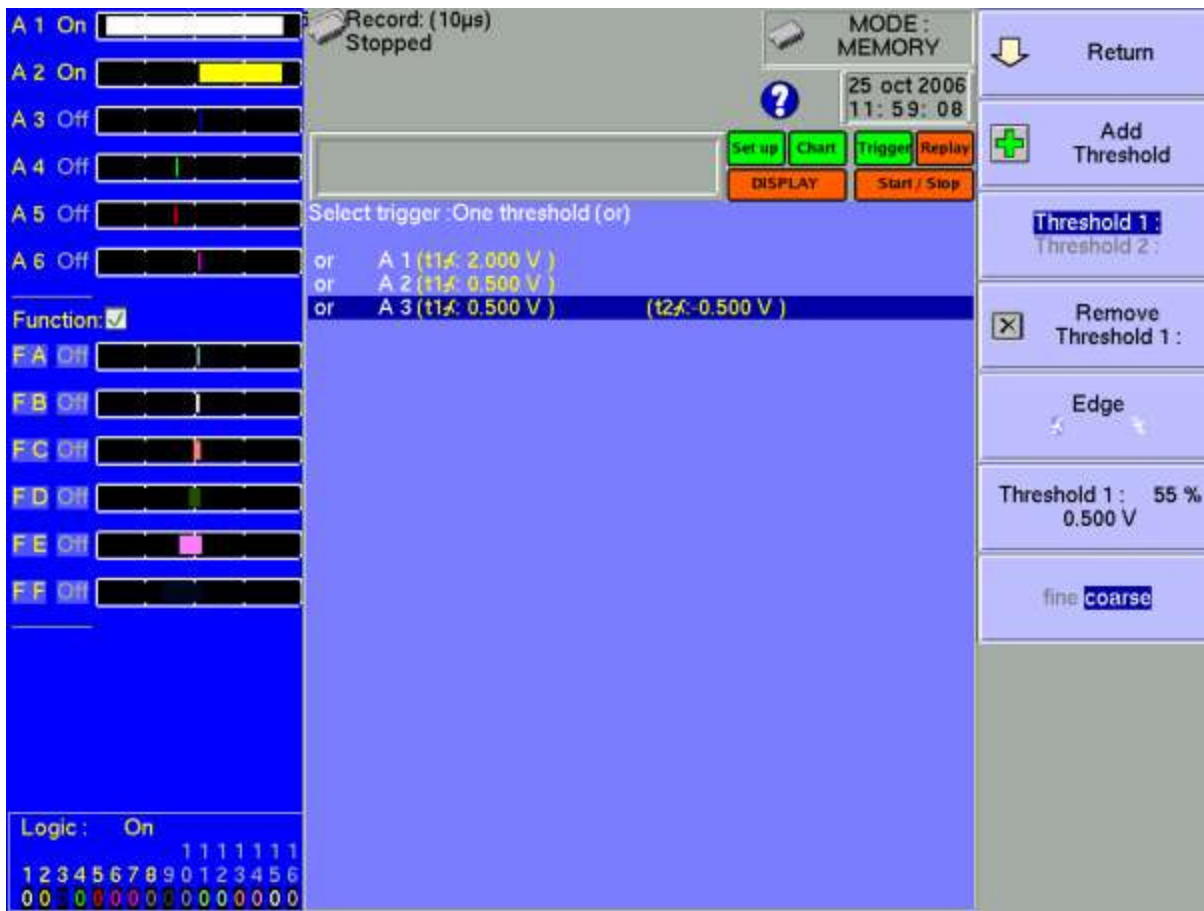

Example: the trigger above is

Triggering if

- Channel A1 increasing and equal to the threshold S1, value 2.000V OR
- Channel A2 increasing and equal to the threshold S1, value 0.500V OR
- Channel A3 increasing and equal to the threshold S1, value 0.500V

The same analysis is worth for the AND trigger (every thresholds).

6.1.4. Trigger according to the slope

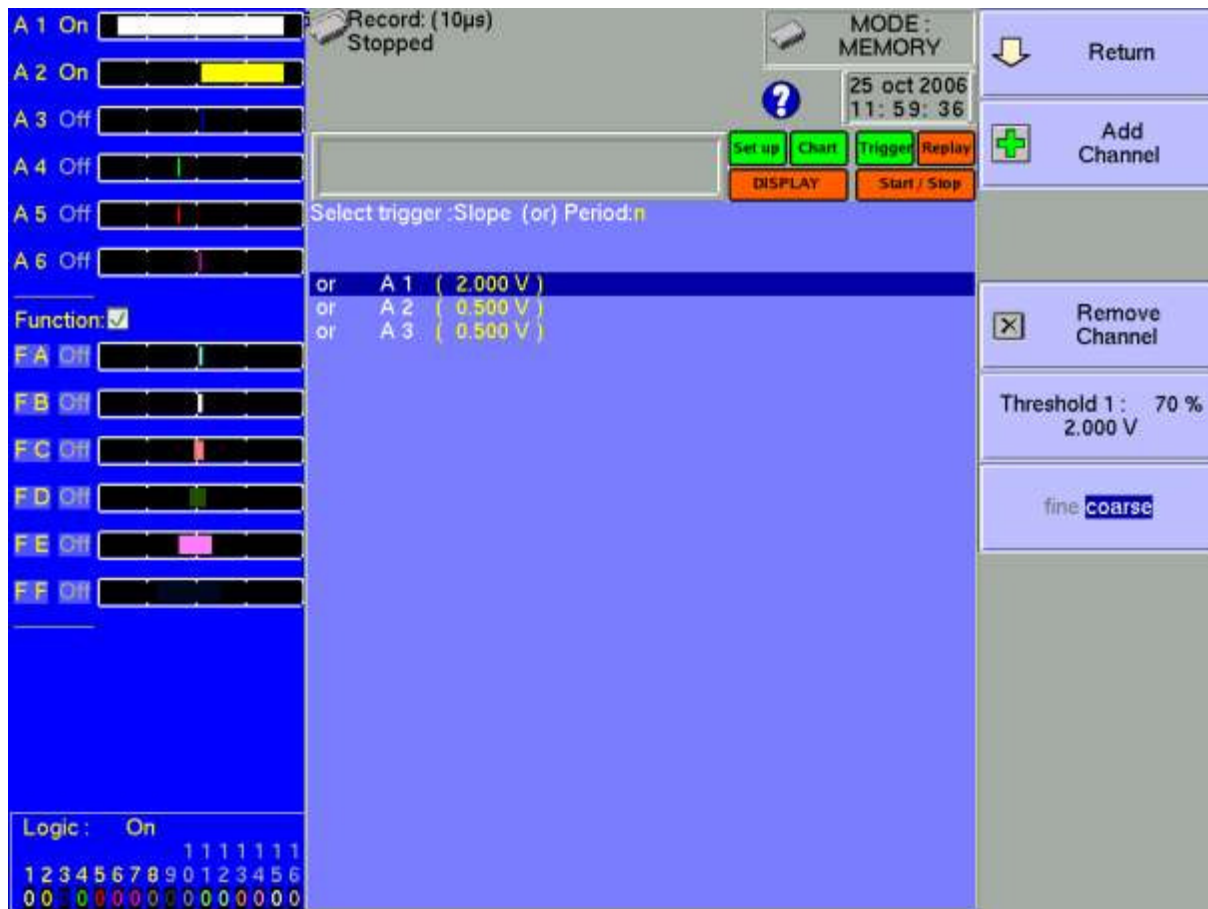

Example: the trigger above is

Triggering if

- | | | |
|------------|---|----|
| Channel A1 | increasing with a positive slope: 2.000V on a 1s period | OR |
| Channel A2 | increasing with a positive slope: 0.500V on a 1s period | OR |
| Channel A3 | increasing with a positive slope: 0.500V on a 1s period | |

The slope is not available for alarms.

6.2. Triggering with logical channels

After selection of the triggering with analogical channels, the following line on screen will allow you to parameter the triggering condition.

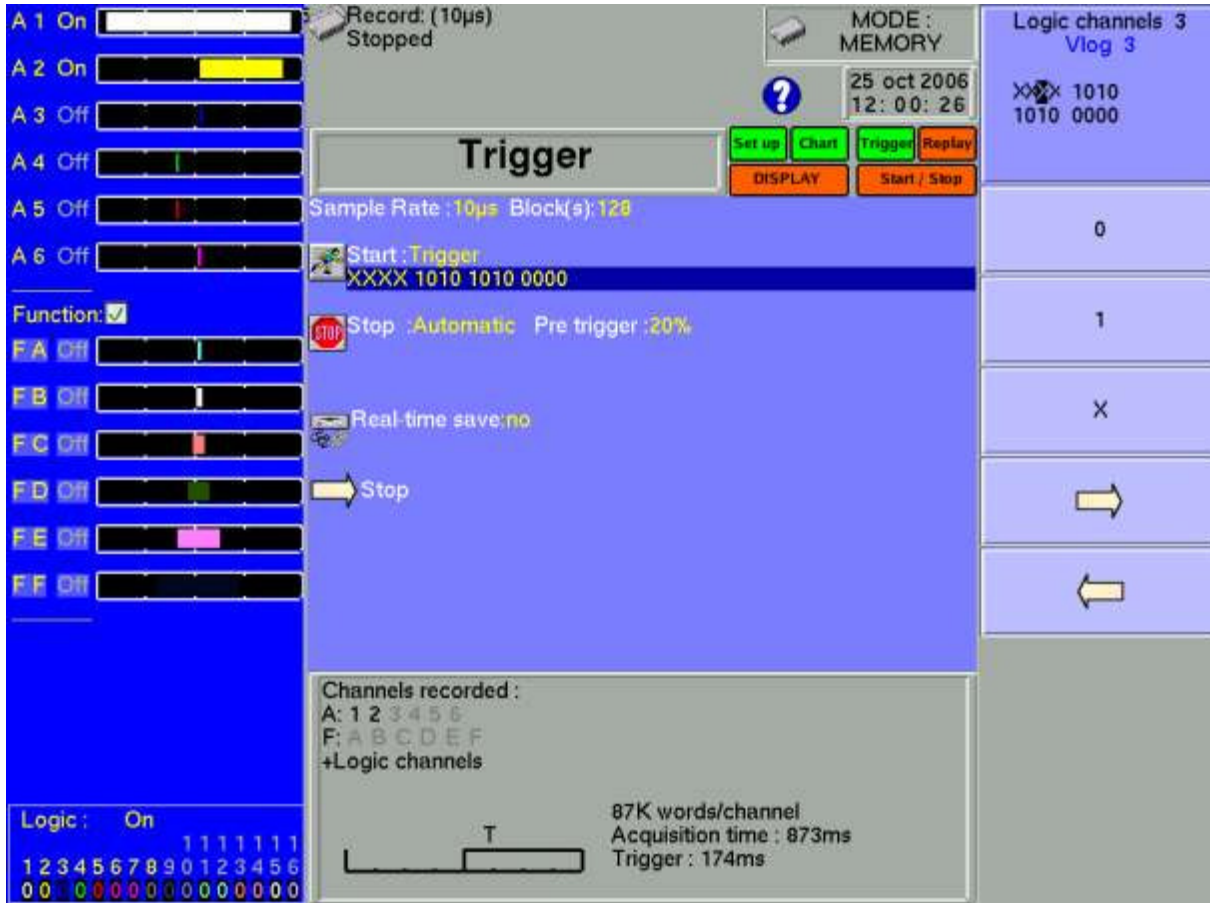

The 16 logical channels can be used in the triggering instruction:

- either active in state 0 (lower than 1.6 volt)
- or active in state 1 (higher than 4.0 volts)
- or not used

AND /OR : using this mathematics functions between each channels.

7. MATHEMATICAL CALCULATIONS

You can make mathematical calculations on achieved acquisitions.

You can access them with the « **Display** » function and the « **Replay** » function if an acquisition is displayed on screen.

7.1. Definitions

Press the « **Math** » key.

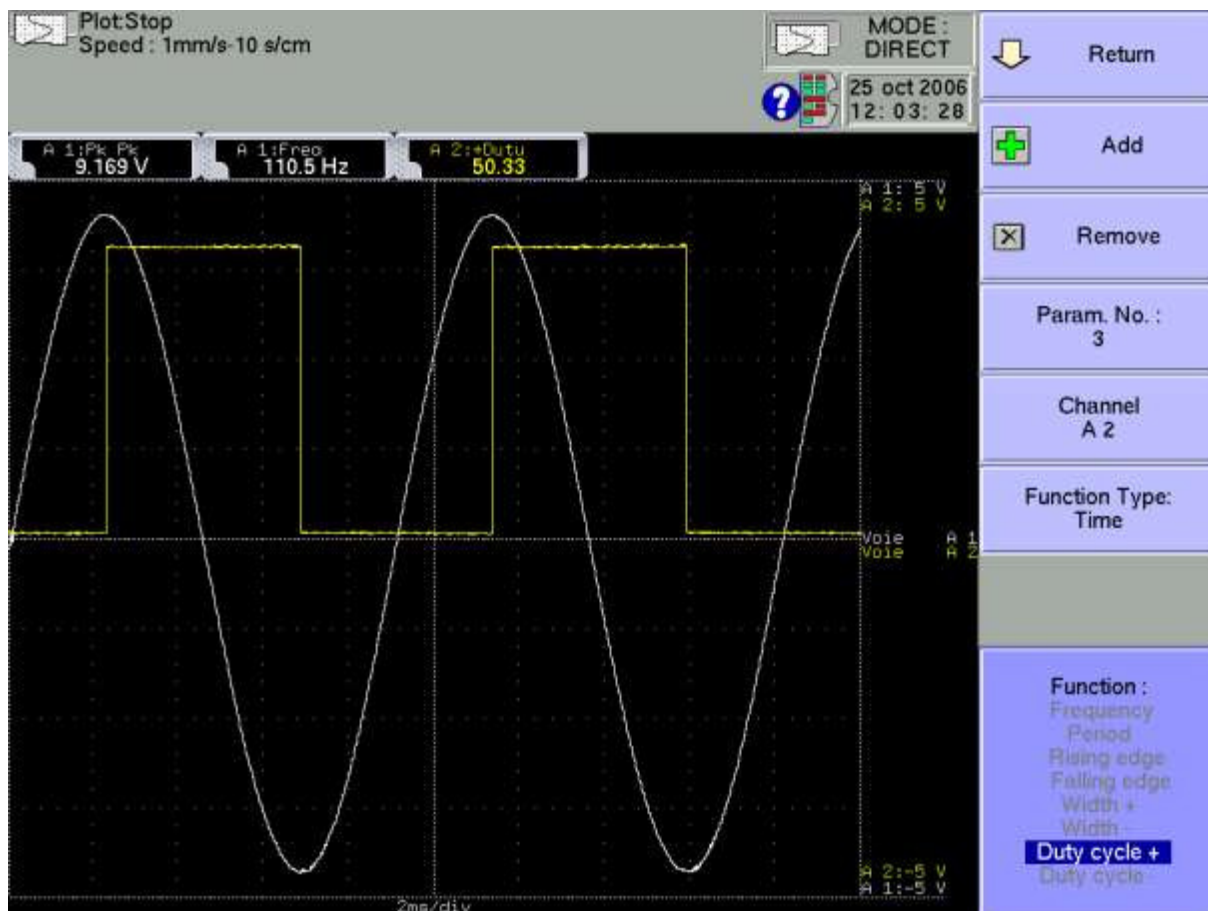

- ➔ **Add:** add a mathematical calculation
- ➔ **Remove:** delete one of the displayed mathematical calculations
- ➔ **#Param:** selection of the number of the displayed calculation for modification
- ➔ **Channel:** selection of the channel on which the selected calculation of « # param » will be made
- ➔ **Function Type:** type of calculation made in the selected calculation of « # param »
- ➔ **Function:** selection of the calculation function made in the selected calculation of « #Param »

7 – Mathematical calculations

You can choose among 20 different mathematical calculations in 3 categories:

- **Amplitude:** min values, max values, peak to peak, base, highest, amplitude, overshoots
- **Time:** frequency, period, increasing time, decreasing time, positive widths, negative widths, positive and negative duty factors
- **Calculation:** average values, cyclic average, cyclic RMS and effective RMS

You can display up to **5 simultaneous calculations** on screen.

The display is made in rectangles above the diagrams where are also specified:

- the number of the channel (with its colour)
- the type of calculation
- the value of the calculation

In « **Display** » function, the calculations are made in real time and the display is updated every 300 ms.

The calculation is made on the 1000 dots displayed on screen. Thus, the time resolution is 0.1 %.









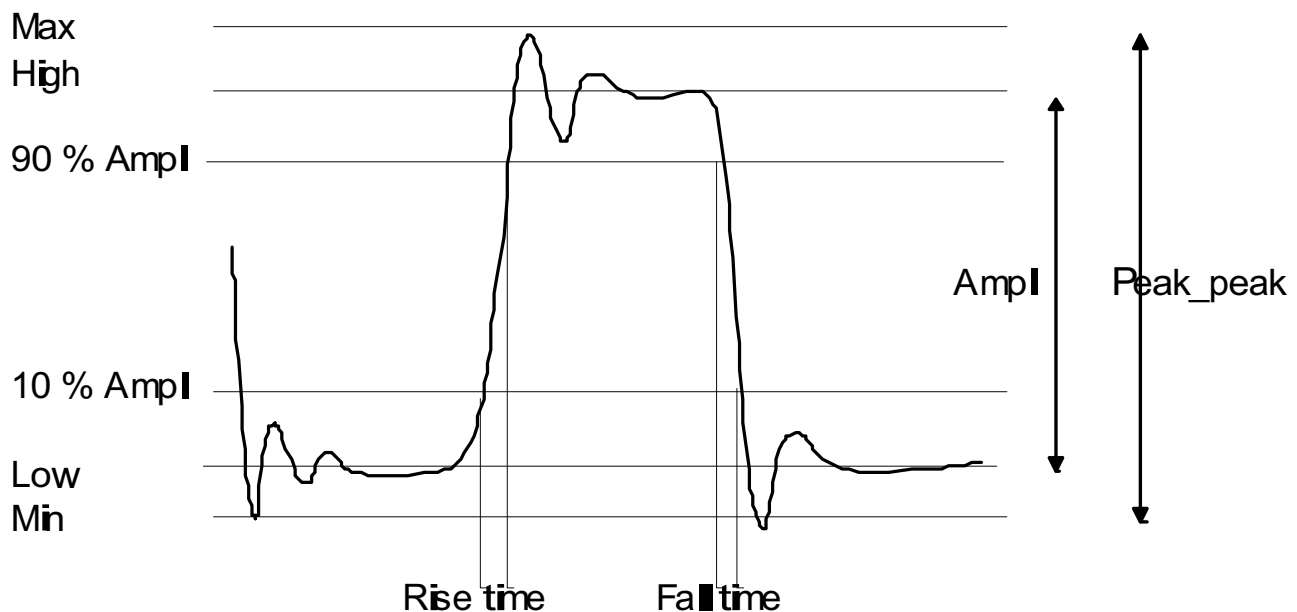

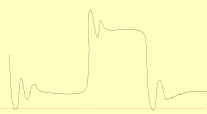
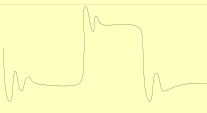
The calculations can concern every channels. However, you cannot assign calculations:

- on the supplementary channels that are functions of other channels (example $F3=A1+B2$)
- if the channels have been recorded (validation ON/OFF)

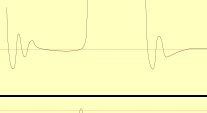
7.2. Types of calculations

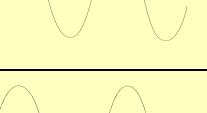

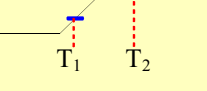
Explicative scheme	Math. Functions	Calculation	Remarks
	Minimum		The lowest negative voltage
	Maximum		The highest positive voltage
	Peak_Peak	Max – Min	
	Low		The most frequent value below the centre
	High		The most frequent value above the centre
	Amplitude	High – Low	
	Positive overshoot	$\frac{Max-High}{Amplitude} \times 100$	
	Negative overshoot	$\frac{Low-Min}{Amplitude} \times 100$	
	Frequency	$\frac{1}{Period}$	Average frequency
	Period	$\frac{Duration\ of\ N\ full\ period}{N}$	Average duration of a total cycle, calculated on as many periods as possible
	Rise time	T ₁ = 10% Amplitude T ₂ = 90% Amplitude Increasing time = T ₂ – T ₁	

7 – Mathematical calculations

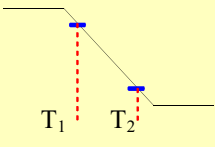
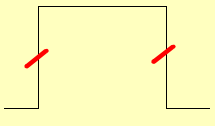
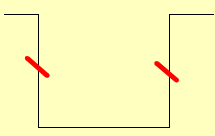
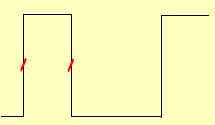
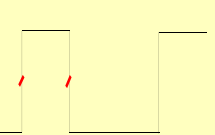
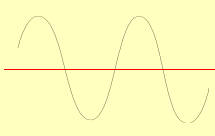
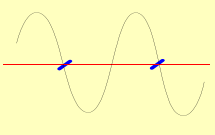
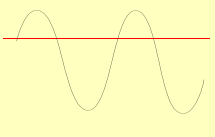
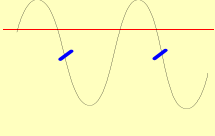
	Fall time	$T_1 = 90\%$ Amplitude $T_2 = 10\%$ Amplitude Decreasing time = $T_2 - T_1$	
	Positive pulse width	Measure of the duration of the <u>1st positive impulsion</u> . Made at 50% of the amplitude	
	Negative pulse width	Measure of the duration of the <u>1st negative impulsion</u> . Made at 50% of the amplitude	
	Positive cycle time	$\frac{\text{duration of positive impulsion}}{\text{period}}$	
	Negative cycle time	$\frac{\text{duration of negative impulsion}}{\text{période}}$	
	Average	$Moy = \frac{1}{N} \times \sum_{i=1}^N V_i$ N: total number of dots	Calculation on the whole graphic window
	Cyclic average	$Moy = \frac{1}{N_2 - N_1} \times \sum_{i=N_1}^{N_2} V_i$ N ₂ -N ₁ : number of dots between complete periods	Calculation on as many periods as possible
	RMS	$RMS = \sqrt{\frac{1}{N} \sum_{i=1}^N V_i^2}$	Calculation on the whole graphic window
	Cyclical RMS	$RMS = \sqrt{\frac{1}{(N_2 - N_1)} \sum_{i=N_1}^{N_2} V_i^2}$	

8. DIRECT MODE

This chapter describes the **Direct** mode of the chart recorder recorder, designed to plot in real time on thermal paper the measures achieved on the channels.



This mode does not exist on paperless recorders.

You can trigger the start and stop of the plotting under various conditions.

You can activate a simultaneous saving of the measurements in an internal memory or in a file.

8.1. Configuration of the plotting

Press the « **Chart** » key.

Definition of every characteristics of the paper plotting.

The screenshot shows the 'Chart' configuration screen. On the left, there are channel status indicators (A1 to A6) and function keys (FA to FF). The main area displays the following settings:

- Plot Stop Speed : 1mm/s-10 s/cm
- MODE : DIRECT
- 25 oct 2006 12: 04: 23
- MODE : F(t) Paper Speed 1mm/s-10 s/cm
- Grid Pattern: 10 mm large
- Trace title : motor 1 start up
- Time : Absolute
- Boundary : Disabled
- Annotation : At start of plot
- Channel names : Enabled
- No. of channels : Enabled
- Annotation type : Min/Max
- Write message: Plot a BMP file
- Logic : Off

On the right side, there are additional settings for MODE (F(t) Numeric), Internal/External storage, and speed units (mm/h, mm/min, mm/s).

- ➔ **Mode:** choice of the printing mode
 - **F(t):** printing a graph versus the time
 - **Numeric:** printing digital values of the measures in a table

- ➔ **Paper speed:** printing speed
 - internally rated feed from 1 mm/h up to 200 mm/s
 - externally rated feed through the logical channel 16

- ➔ **Grid Pattern:** definition of the grid pattern plotted on the paper
 - none, every 5 mm, 10 mm or with an integer number of divisions
 - fine or wide, i.e. with or without subdivisions
 - access to the « Change Diagrams » to organise the presentation of the channels on the paper (see chapter **Diagrams**)

- ➔ **Title:** giving a title (max. 124 characters) for printing. It will appear at the top of the paper sheet.

- ➔ **Time:** type of time reference, printed at the beginning of the plotting and with every annotation
 - absolute: real-time hour and date
 - relative: setting to zero at the beginning of the plotting, printing the elapsed time after each new annotation.

- ➔ **Boundary:** possibility to write the limits of each channel (min-max) and the position of zero at the end of the plotting

- ➔ **Annotation:** possibility to have annotations while printing
 - no, at the beginning of the plotting, on an alarm or on a length of paper
 - made of the name, the number, the current value or the range of the channels

- ➔ **Write Message:** you can also write a text directly on the paper
 - after entering your text, press the « Write » key: the text will be immediately plotted on the paper
 - if the plotting has begun, it will be paused and will start again when the line is written.

- ➔ **Plot a BMP file:** you can write a file under BMP format (bitmap windows). The BMP file must be single colour (height 2000 pixels maximum). The must be on the hard disk, and can be copied with an USB key or via ftp link

8.2. Triggering plotting

Press the « **Trigger** » key.

Trigger

Programming the start and stop conditions of the plotting.

Selection of the actions after the plotting and validation of the saving in real time.

- **Mode:** selection of the printing mode
 - **F(t):** printing a graph versus the time
 - **Numeric:** printing digital values of the measurements in a table
- **Paper speed:** printing speed
 - **internally** rated feed **from 1 mm/h up to 200 mm/s**
 - **externally** rated feed through the **logical channel 16**
- **Speed before Trigger:** printing speed **before** the start trigger; possible if the start trigger is not Manual
- **Start:** condition for starting the plotting
 - **Manual:** with the « Record » key
 - **Trigger:** with an association of the analogical or logical channels see Chapter 6 **Trigger**
 - **Wait for:** after a delay or at a precise date and time
- **Stop:** condition for stopping the plotting

- **Manual:** with the « Record » key
 - **Trigger:** with an association of the analogical or logical channels see Chapter 6 **Trigger**
 - **Wait for :** after a delay or at a precise date and time
 - **Paper length:** after writing a programmed length of paper
- ➔ **After end of plot:** action after the end of the plotting; only possible if the start and stop triggers are not Manual
- **Stop:** no action
 - **Rearm:** waiting for the start trigger
 - **Change Setup.:** loading a configuration and waiting for the start trigger
- ➔ **Save Data:** simultaneous saving of the measurements in internal memory or on a file
- **No save:** no simultaneous saving
 - **Memory:** recording in internal memory
 - **Acquisition period:** sampling speed of the channels
 - **Blocks:** dividing the internal memory into blocks
 - **File:** recording on a file
 - **File name:** place and name of the saving file
 - **Acquisition period:** sampling speed of the channels



See chapter **File mode** to know the limitations of the file recording

- ➔ **Trigger:** condition for stopping the simultaneous saving in internal memory only
- **Direct:** the same as for paper printing
 - **Manual:** with the « Record » key
 - **Trigger:** with an association of the analogical or logical channels see Chapter “ **Trigger** ”
 - **Pre-triggering:** position of the trigger in the memory (in the block)
- ➔ **Following:** actions after the end of the simultaneous acquisition into the **memory**
- **Save on file:** saving the acquisition into a file
 - **Plot:** writing the simultaneous acquisition into the memory
 - **Rearm.:** reloading the writing; waiting for the start condition again



- If a speed before start has been programmed, the paper will be fed at this rate while waiting the trigger.
- The user can urge the trigger at any time by pressing the "**Start/Stop**" key again while waiting for the start
- While plotting, pressing this key will stop the plotting
- In case of power failure while plotting, the recorder will start again in the same status (waiting or writing)

8.3. Rearmament of the plotting

In rearm. mode, waiting for the start of the plotting is automatically reloaded when the stop conditions arouse.

To interrupt the cycle, you only have to urge the stop of the plotting by pressing the "Start/Stop" key while plotting.

8.4. Writing data

At the beginning of each plotting are written the date, the hour, the programmed title at the top of the paper sheet.

The number of each channel is written on the plotting.

8.5. Example of plotting program

We would like to trigger the plotting of the channel 1 when the channels 3 and 4 are both above 50% of the full scale.

Before triggering, the plotting will be made at low rate (5 mm/s).

After triggering, the recorder will draw 50 cm paper at 50 mm/s, then the configuration "Config 3" will be loaded.

Program:

→ in « **DIRECT** » mode with the « **MODE** » key

→ « **Chart** » key:

Here, you can define all that concerns the plotting on paper

In our case, only 1 diagram on 250 mm

Here, you could give the plotting a name and call the writing of annotations.

→ « **Trigger** » key

→ « **Paper speed** »: 50 mm/s

→ « **Start** »: Trigger

- « **Speed before trigger** »: 5 mm/s

- « **Analogic channels** »

- « **Several thresholds** »

→ Definition of the start condition on the following line:

→ « **Call** »:

- « **Every thresholds (AND)** »

- following line: « **add a threshold** »

- channel A3, threshold 1, increasing front, Add

- adjust the threshold 1 at 50%

- « **add a threshold** »

- channel A4, threshold 1, increasing front, Add

- adjust the threshold 1 at 50%

→ « **Stop** »: Paper length

- paper length: 500 mm

→ « **After end of plot** »: Change Config.

- « **Configuration** »: in our case: "3"

→ « **Save Data** »: in our example, we will leave « **no** »

→ « **Channels on/off** » key

8 – Direct mode

- module A
- Channel A1 « ON »

➔ « Channels set up » key

- select the range and the zero so that the channel is centred on the paper

Recording:

Press the "**Start/Stop**" key.

The writing begins at a 5mm/s rate and waits for the trigger start condition.

When both channels A3 and A4 have reached the programmed threshold on increasing, the trigger start is validated.

The writing turns to a 50mm/s rate and keeps on 50 cm, thus 10 s.

After these 10 seconds, it turns directly to the configuration 3.

When the new configuration is ready, the recorder proceeds as if the user had pressed the "**Start/Stop**" key.

9. MEMORY MODE

This chapter describes the **Memory** mode designed to record in real time into the internal memory the measures achieved on the channels.

You can trigger the start and stop of the plotting under various conditions.

You can activate a simultaneous saving of the measurements in an internal memory or in a file.

9.1. Configuration and triggering of the acquisition

Press the « **Trigger** » key.



Definition of the acquisition into internal memory.

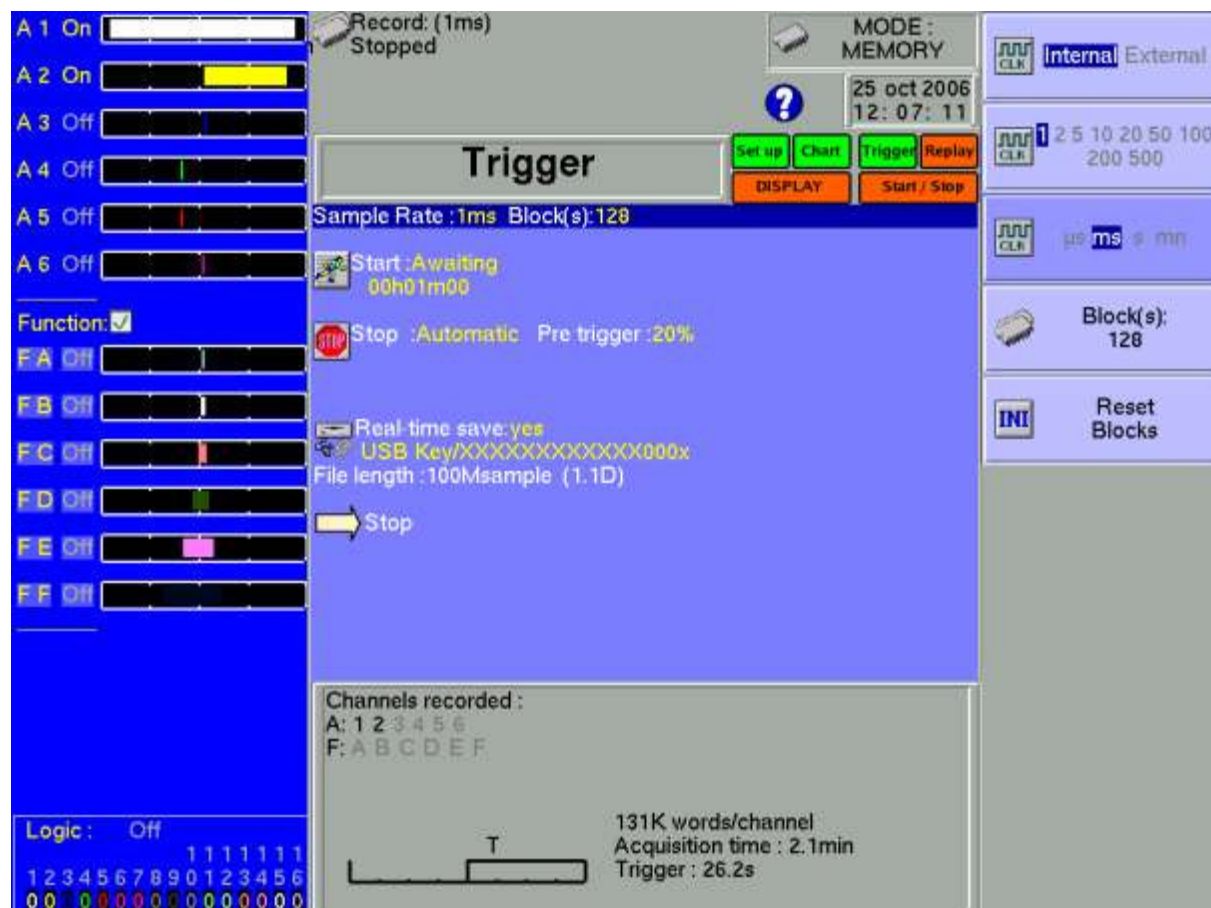

→ **Sample Rate:** sampling rate of the channels

- **internally** rated from **1 μ s to 20 min**
- **externally** rated through the **logical channel 16**

→ **Blocks:** division of the internal memory into blocks

- 1, 2, 4, 8, 16, 32, 64 or 128
- **Reset Blocks:** deleting all the blocks: the current block is the #1 block

- ➔ **Start:** start condition of the acquisition
 - **Manual:** with the F2 key « **Urge triggering** »
 - **Trigger:** with an association of the analogical or logical channels - see Chapter 6 **Trigger**
 - **Waiting for:** after a delay or at a precise date and time
 - **Automatic:** immediate; automatic stop when the block is full

- ➔ **Pre-triggering:** definition of the position of the start trigger in the acquisition
 - pre-trigger and post-trigger of the acquisition (before or after Start); and if the trigger is allowed during pre triggering time

- ➔ **Stop:** stop condition of the acquisition
 - **Automatic:** when the block is full
 - **Trigger:** with an association of the analogical or logical channels - see Chapter 6 **Trigger**

Trigger mode **Double Trigger:** see below

- ➔ **Real-time Saving:** simultaneous recording of the acquisition into a file
 - place and name of the saving file
 - maximum length of the file



« **Impossible** » is displayed when the saving capabilities are overrun: reduce the sampling rate or the number of channels



See chapter **File mode** to know the limitations of the file recording

- ➔ **Following:** actions after the end of the acquisition
 - **Save on file:** saving the acquisition into a file if the real-time saving is not validated (or is impossible)
 - **Plot:** plotting the acquisition
 - **Stop:** no action
 - **Rearm:** waiting for the start condition
 - **Change setup:** loading a configuration and waiting for the start trigger

9.2. Sampling period

When the frequency of the input signals is too high to record them in Direct mode, you must put the measured signals into memory at a high acquisition rate: this is the **Memory mode**

Sampling consists in reading the instant value of a signal at regular time intervals: each of these values is stored in a memory.

So that the acquisition of a periodic signal is convenient, you should select a sampling period that is compatible with the frequency of the signals at the input terminals of the recorder.



10-dot-per-signal-period accuracy is a minimum for a convenient plotting

9.3. Internal memory, blocks

You can divide the available memory of the recorder into blocks that will be filled one after the other at each acquisition.

The amount of data of acquisition is worth $N / (B * V)$

N = total memory

B = number of blocks

V = number of channels to collect

Example: memory: 32 Mbytes, 16 blocks and 3 channels "ON"; you will have

$$N = 32,554,432 / (16 * 3) = 699,050 \text{ bytes/channel}$$

Any new acquisition will be placed automatically into the first free block available (in increasing sense).

When every blocks are full, a new acquisition will shift the previous block N into the block N-1; the 1st block will be lost.

The new acquisition will then take the place of the last block.

9.4. Triggering position

The acquisition into a memory block is based on the system of the « rotary memory »:

- the memory starts filling from the start condition
- the memory keeps on filling as long as the stop condition is not valid; if the memory is full, the filling restarts from the beginning of the memory zone (block)

Thus, the memory block always contains the N last samples.

The user can choose the moment when the samples in the memory will be frozen: to do so, he will define a delay between the triggering moment and the beginning of the effective transfer into memory.

9 – Memory mode

This delay can be positive or negative. The samples in memory can thus be either before or after or on both sides of the triggering moment.

We can also not inhibit the trigger during the pre trigger phase : this allow to test the trigger condition during the pre trigger phase and make the trigger function even if the pre trigger time isn't passed.

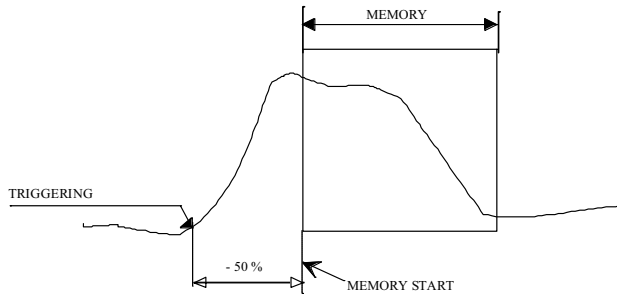

Transfer to memory with a -50% delay relatively to the beginning of the memory

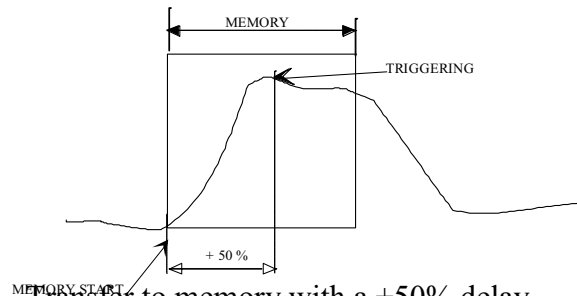

Transfer to memory with a +50% delay relatively to the beginning of the memory

9.5. Double Trigger mode

In this mode, you will use a start trigger and a stop trigger.

You will thus record the measurements between those two triggers.

The acquisition will automatically stop:

- when the stop condition is valid
- or when the memory block is full

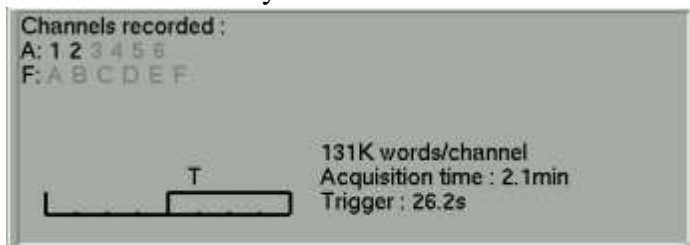

An information window will summarise the general configuration of the acquisition :

- channels and functions between the channels validated for the acquisition
 - number of dots per channel (according to the number of blocks)
- total acquisition time (according to the acquisition rate)
- position of the trigger (according to the pre-triggering)

9.6. Recording

You launch the data acquisition by pressing the « **Start/Stop** » key.

It will appear at the top left of the screen:

- the number of the current block if required
- the current sampling rate
- the status of the acquisition (waiting for triggering, filling xx%...)
- the opening of a saving file if required
- a bargraph where you can recognise the percentage of achieved acquisition and the percentage of displayed acquisition.

The menu key F1 « **Stop** » allows you to stop the current acquisition.



If the acquisition time of the record is less than 2 minutes, the whole acquisition will be displayed. You won't be able to exit this page then: the acquisition must be stopped before you can change of menu.

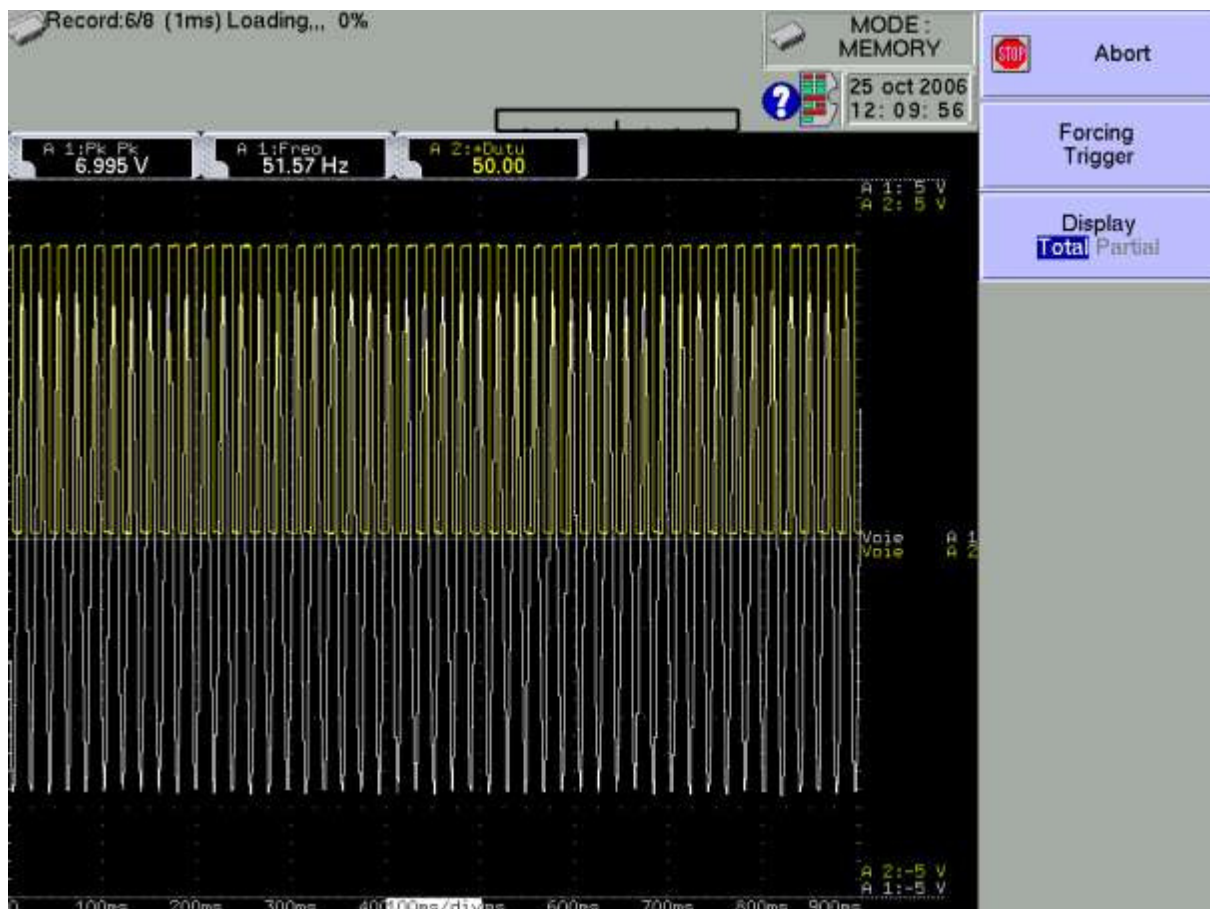

9 – Memory mode



For longer acquisition times, you can zoom on a portion of the data or change the page. After changing the menu page, you can go back to the acquisition by pressing the "Start/Stop" key.

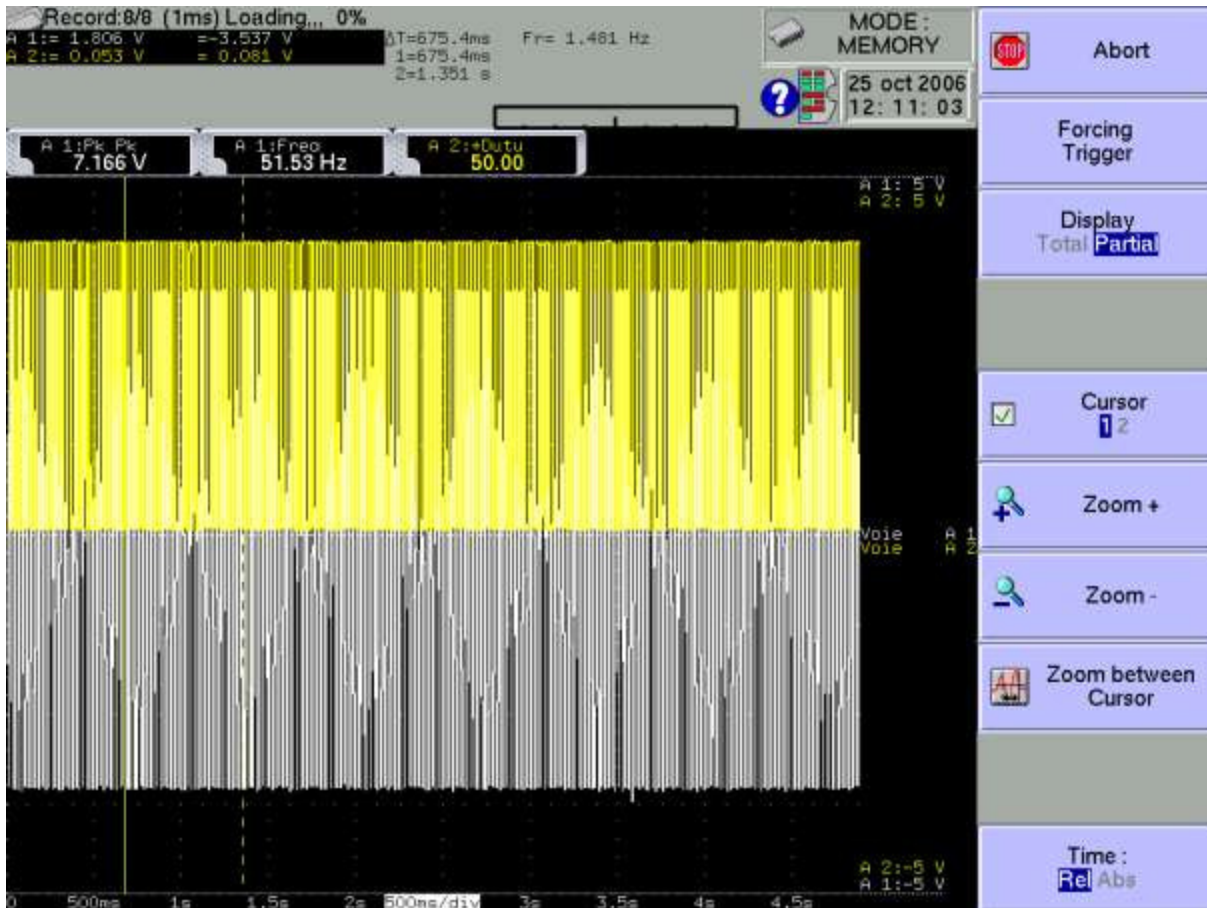

Supplementary menu keys:

→ Display:

- Total: the whole data memory is displayed and updated during the acquisition.
- Partial: only a part of the data memory is displayed; the display is frozen; only the bargraph and the percentage of achieved acquisition let you know the status of the acquisition; you have then access to the time and zoom cursors.



You cannot display another block than the current one. You cannot plot or save to file the acquisition as long as it is not over.

At the end of the acquisition process, the appliance switches automatically to memory display function « **Replay** ».

9.7. Memory output

Display of the acquisitions available in the internal memory or in files.
Possibility to launch the paper printing of the acquisitions.

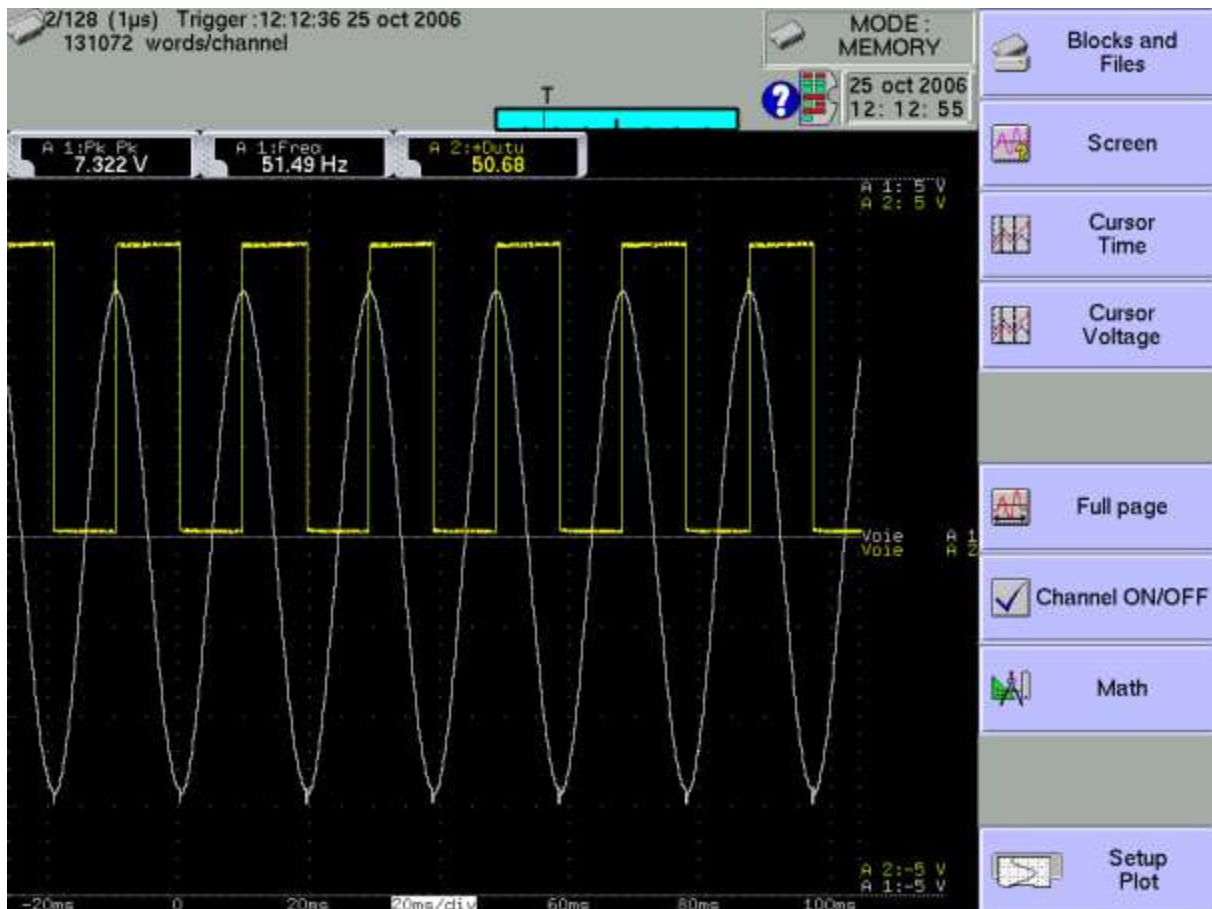

- **Blocks and files:** choice of the memory block or of the file to display; if there is no valid block, the only existing menu key is « **Load file** ».
- **Screen:** type of display, diagrams; see chapter **Use**
- **Time cursor:** vertical cursors, zoom; see chapter **Use**
- **Voltage cursor:** horizontal cursors; see chapter **Use**
- **Full page:** display of the whole data memory
- **Channel On/Off:** validation of the channels ON/OFF
- **Math. calculation:** adding automatic measurements on the screen; see chapter **Use**
- **Setup plotting:** configuration of the plotting of the acquisition; « **Launch plotting** » key

At the top left of the screen, it will then appear:

- the number of the displayed block
- the sampling rate
- the date of the trigger
- the number of dots per channel in this block
- a bargraph where the filling percentage of the block and the position of the trigger are displayed.

10. GO/NOGO MODE

This chapter describes the **Go/Nogo Mode** designed for the real-time recording into the internal memory the measures achieved on the channels.

You can trigger the acquisition under various conditions. You can **stop** it when measures exceed a previous acquisition defined as a **Frame**.

You can activate a simultaneous saving of the measures on a file.

10.1. Configuration and triggering of the acquisition

Press the « **Trigger** » key.



Definition of the acquisition into internal memory with frame.

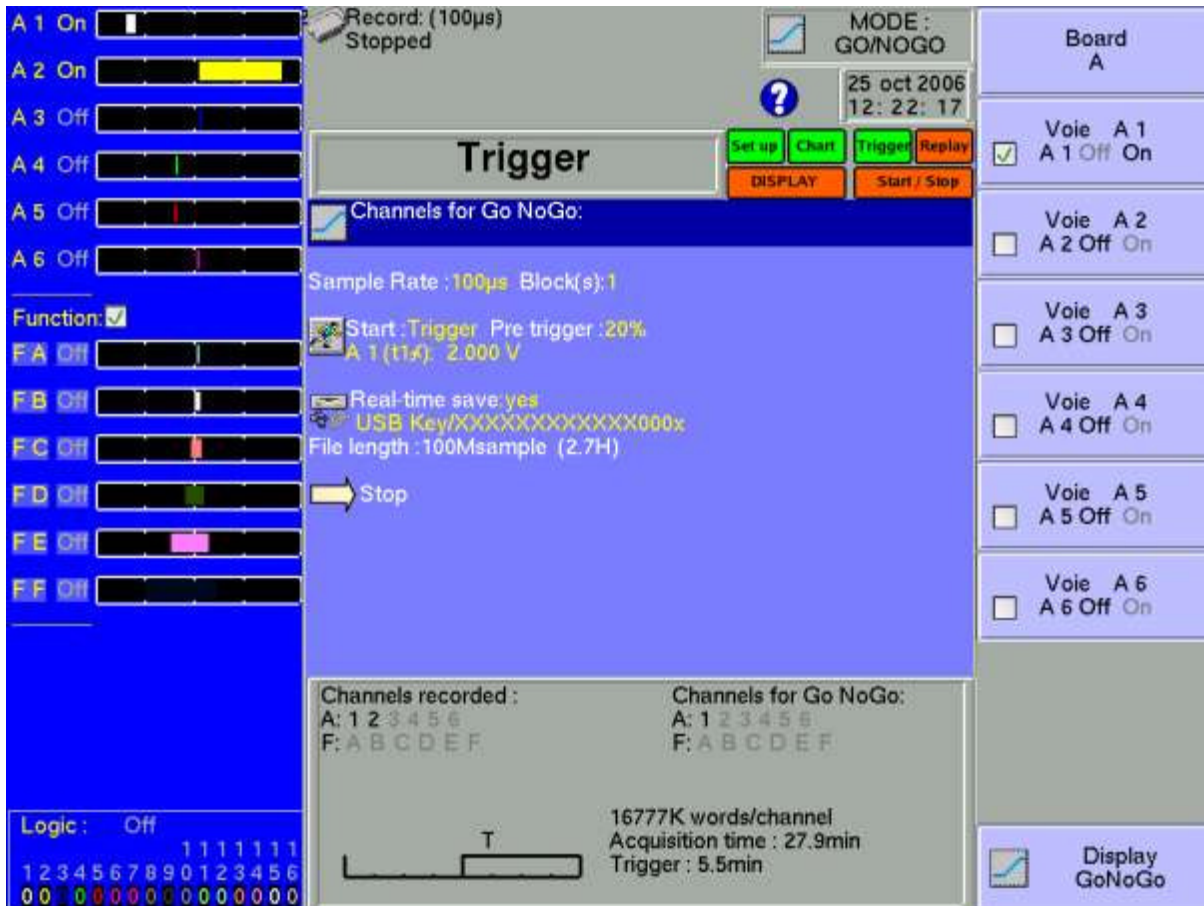

10 – Go/Nogo mode

- **Channels for Go/Nogo:** channels to compare to the frame; access to the definition of the frame
- **Sample rate:** sampling rate of the channels
 - **internally** rated from **1 μ s to 20 min**
 - **externally** rated through the **logical channel 16**
- **Blocks:** division of the internal memory into blocks
 - 1, 2, 4, 8, 16, 32, 64 or 128
 - **Raz Blocks:** deleting all the blocks: the current block is the #1 block
- **Start:** start condition of the acquisition
 - **Manual:** with the F2 key « **Urge triggering** »
 - **Trigger:** with an association of the analogical or logical channels - see Chapter 6
Trigger
 - **Waiting for:** after a delay or at a precise date and time
 - **Automatic:** immediate; automatic stop when the block is full
- **Pre-triggering:** definition of the position of the start trigger in the acquisition
 - pre-trigger and post-trigger of the acquisition (before or after Start); see chapter **Memory Mode**
- **Real-time Saving:** simultaneous recording of the acquisition into a file
 - place and name of the saving file
 - maximum length of the file



« **Impossible** » is displayed when the saving capabilities are overrun: reduce the sampling rate or the number of channels



See chapter **File mode** to know the limitations of the file recording

- **Following:** actions after the end of the acquisition
 - **Save on file:** saving the acquisition into a file if the real-time saving is not validated (or is impossible)
 - **Plot:** plotting the acquisition
 - **Stop:** no action
 - **Rearm.:** waiting for the start condition
 - **Change Setup:** loading a configuration and waiting for the start trigger

10.2. Creation of the frame

Make a normal acquisition or display a previously recorded file with the function « Memory output ».

In the page « **Trigger** », select the parameter « **Channels for Go/Nogo** » then « **Visualize the frame** » then « **Modify** ».

The appliance will then display the current frame. It appears as 2 curves (a min and a max curve) around the channel selected as a reference for the frame.

Both curves have been saved in non-volatile RAM internal memory.

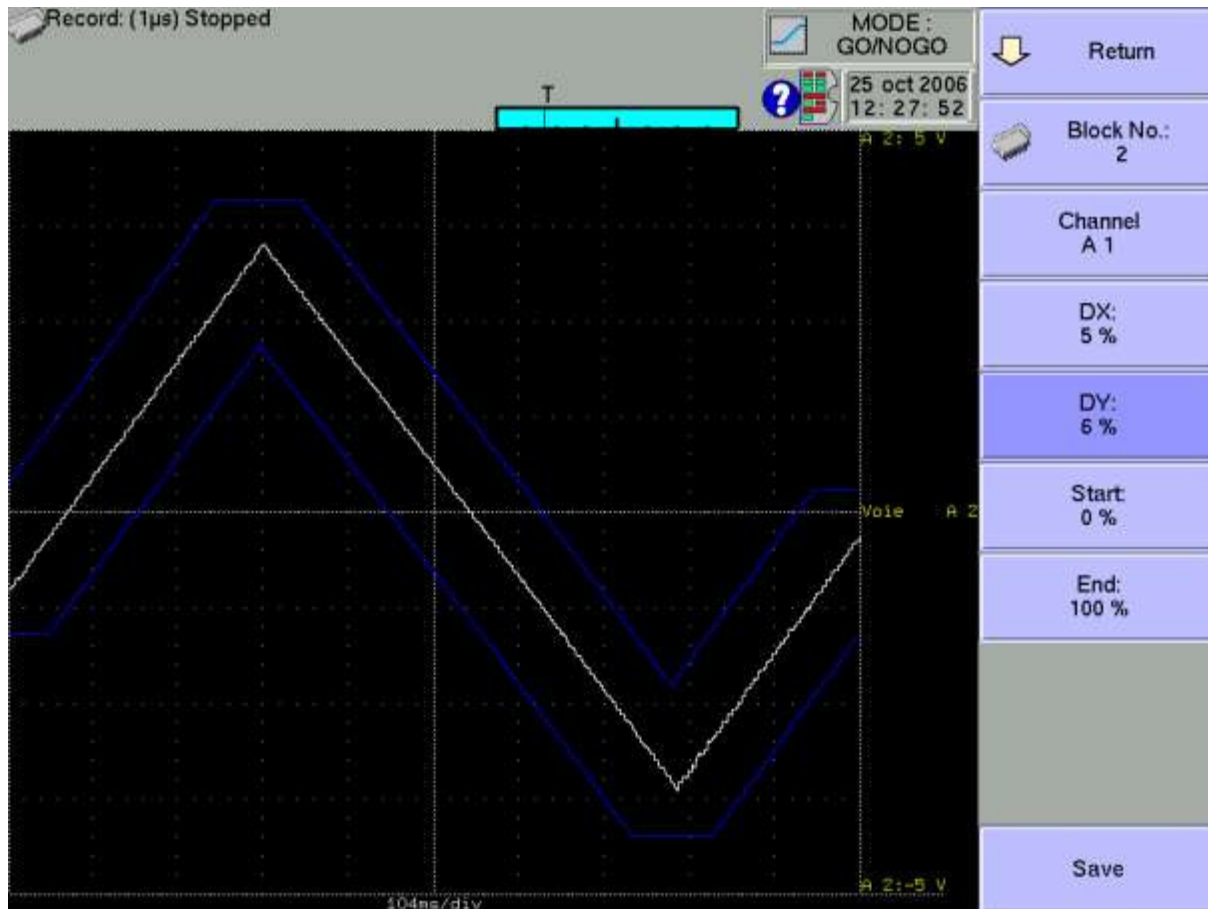

- **Return:** returns to the previous page, the frame won't be changed
- **Block number:** allows you to select the reference block
- **Channel:** allows you to select the reference channel
- **DX and DY:** allow you to plot the 2 curves min and max
- **Begin and End:** limits of the memory space used for the trigger stop test
- **Save:** as soon as the frame is correct, you can save it into ROM internal memory.



You cannot save a frame on a **file**. To keep a frame on a file, save the block and the channel that will allow you to recreate the frame for a new use.

10.3. Use of the frame

The comparison with the frame is used to stop the acquisition. This comparison will be made on the « **Channels for Go/Nogo** » selected in the « **Trigger** » page.

The information window at the bottom of the « **Trigger** » page summarises the general configuration of the acquisition:

- channels and functions between channels validated for the acquisition
- channels and functions between channels compared with the frame
- number of dots per channel (according to the number of blocks)
- total acquisition time (according to the acquisition rate)
- position of the trigger (according to the pre-triggering)

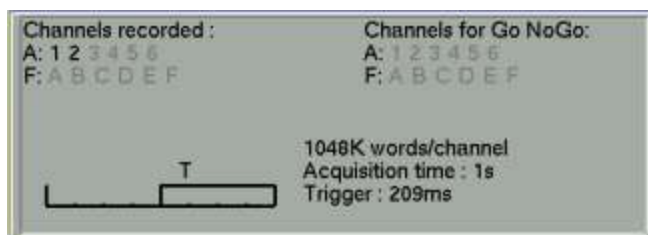

The comparison with the frame can only be made when the channels have been validated for the acquisition. An error message will display when you have selected « **Channels for Go/Nogo** » that have not been validated (ON).

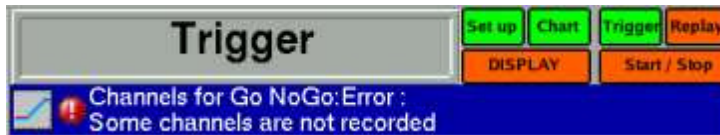

The acquisition is made as previously (see chapter **Memory mode**).

When the memory block is full, the appliance will check that every collected dots on the frame channels are the 2 min and max reference curves of the frame.

If every dots are within the frame, the acquisition will start again (in the same block). Else, the acquisition will stop.

11. FILE MODE

This chapter describes the **File** mode designed for real-time record on a file of the measures achieved on the channels.

You can trigger the start and stop of the plotting under various conditions.

11.1. Configuration and start of the acquisition

Press the « **Trigger** » key.

Trigger

Definition of the acquisition into a file.

- **File name:** place and name of the acquisition file
- directory (place) of the acquisition file
 - name of the acquisition file
 - type of the acquisition file: binary or text

- ➔ **Sample rate:** sampling rate of the channels
 - **internally** rated from **1 μs to 20 min**
 - **externally** rated through the **logical channel 16**

- ➔ **Start:** start condition of the acquisition
 - **Manual:** with the F2 key « **Urge triggering** »
 - **Trigger:** with an association of the analogical or logical channels - see Chapter 6
Trigger
 - **Waiting for:** after a delay or at a precise date and time
 - **Automatic:** immediate; automatic stop when the block is full

- ➔ **Stop:** stop condition of the acquisition
 - **Automatic:** when the block is full
 - **Trigger:** with an association of the analogical or logical channels - see Chapter 6
Trigger

Trigger mode **Double Trigger:** see below **Memory mode**

- ➔ **Record:** You can choose the maximum length of file and a pre_trigger time (number of sample).
- ➔ **Following:** actions after the end of the acquisition
 - **Stop:** no action
 - **Ream:** waiting for the start condition
 - **Change Setup:** loading a configuration and waiting for the start trigger

Secondary file :

A secondary file can be create if the sample rate of the first file is <200μsec .

The valid channels can be different . The sample rate of this file is >10milliseconde.

So it's possible to record somme channels very fast in a file , and record others channels (temperature for example) in the slow file in the same time.

11.2. Annotation

While recording, you can annotated the file, a vertical line will be associated with a message (choose texte with key F8 :and will be add to the file when you press the key F9 (Launch Annotation).

The software SeframViewer allow you to visualize this annotations on a PC.

11.3. Limits

Real-time acquisitions on file are limited by the transfer rate between the inputs and the saving hardware like an internal hard disk or a USB key.

This limit depends on the type of the acquisition file: binary or ascii.

It is advised not to use big files. For example you need 5mn to open a “rec” file of 170Mbytes with Flexpro software.

11.3.1.Binary file

The maximum transfer rate is 1,200,000 sample/s (1.2 Msample/s).

In order to know the number of channels that you can record for a given acquisition period, you have to calculate:

$$\text{number of channels} = 1,200,000 \times \text{acquisition period}$$

example: acquisition period: 10 μ s
 number of channels = 1,200,000 x 10 μ s = maximum 12 channels

11.3.2.Ascii file

The maximum transfer rate is 1,000 sample/s (1.0 Ksample/s).

The minimum sample rate is 1ms.

In order to know the number of channels that you can record for a given acquisition period, you have to calculate:

$$\text{number of channels} = 1\ 000 \times \text{acquisition period}$$

example: acquisition period: 10 ms
 number of channels = 1 000 x 10ms = maximum 10 channels



« **Impossible** » is displayed when the saving capabilities are overrun: reduce the sampling rate or the number of channels

12. POWER ANALYSER

12.1. PRESENTATION

The recorder may have a Power analyser option. It makes it possible to measure powers and harmonics. Measured values can be tracked in real time or recorded.

The channels that are not dedicated to the power and work normally. For example, in three-phase current mode, it may be interesting to record the neutral current on other channels.

It is also possible to record logical channels.



THIS FUNCTION IS NOT AVAILABLE WITH APPLIANCES THAT DO NOT HAVE A 6-CHANNEL ISOLATED INPUT CARD

The set-up of the PowerAnalyser includes:

- Launching : thanks to the "Mode" key. Then, you select "PowerAnalyser".
- Description of the network and the wiring: Menu "Channel"
- Selection of the type of analysis and of the desired values: Menu "Trigger"
- Viewing (oscilloscope, digital, harmonics): Menu "Direct Visual."
- Acquisition: "Record" key.



Attention:

The connection of the inputs on the tested installation should be made by an authorised personal
Connect the grounding before connecting live lines

12.1.1. Installation: Menu " SET UP. Channel"

In the MODE page, change the mode by pressing the "Power Analyser" key. You directly access the page of channel configuration.

In this page, you choose the type of network and the parameters of the inputs.

The first line allows the automatic selection of the fundamental configuration of the network to use (one-phase, two-phase or three-phase network – star or delta mode)

A RESET key returns to the default configuration of the channels.

- Tension measurement: "Direct" or "Converter". If the tension of the network is to be watched through a converter, you should select this configuration. Then, you have to input the conversion rate.
- The appliance will select automatically the right rating: you only have to specify the nominal tension of the network. Beware: if this value is too different from the true tension, this could lead to rating overruns or to some inaccuracy of the measures.
- Current measurement: The same is worth as for tension. You choose the current input type (clamp, converter, shunt). In each configuration, you'll have to select associated parameters.
- For "Clamp": primary current, secondary tension (these are current/tension clamps)
- For "Converter" (converter + shunt): primary and secondary currents and value of the shunt
- For "Shunt": value of the shunt, in ohms
- You also have to define the nominal current like the nominal tension.

- In three-phase mode, if the network is symmetrical, you may have only 2 current inputs used: the third will then be calculated
- Default frequency: in case where the appliance would not have automatically detected the fundamental frequency, the calculations would take into account the value that you will input here.
- The acquisitions are synchronised with the calculation of the frequency of the channel 1.

Wiring and controls :

The wiring of the network is directly visualised. Any error in the wiring may lead to false results. The colour of the channels matches the colour of each input.

You can see that the tensions U1, U2 and U3 are connected to the odd-numbered inputs A1, A3 and A5.

The currents I1, I2 and I3 are connected to the even-numbered inputs A2, A4 and A6.

For instance, in two-phase mode, the available channels are A5 and A6.

Fresnel diagram:

You can also check the accuracy of the wiring by visualising the Fresnel diagram. The size of the arrows is not proportional to the RMS value of the intensities. It's the responsibility of the user to check the coherence of what is displayed.

The position of the tension arrows is calculated in relation with the tension V1. So, it is possible to find out whether the wiring is direct or reverse: the current vectors are calculated in relation with the corresponding tensions.



Attention: Even though nothing odd may appear, mistakes may have been committed. Anyway, the wiring must be achieved carefully by qualified people.

Warning messages:

At any moment, such messages may appear in red on top of the screen:

- **Impossibility to synchronise the signal** - the frequency is too high, the signal is too weak or too noisy.
- **Rating overrun** - The tension or the intensity is too high in comparison with the input nominal value: you must change this value or use another probe.

12.1.2. Visualisation of the signal

By pressing the "Direct Visualisation" key, you access the following windows:

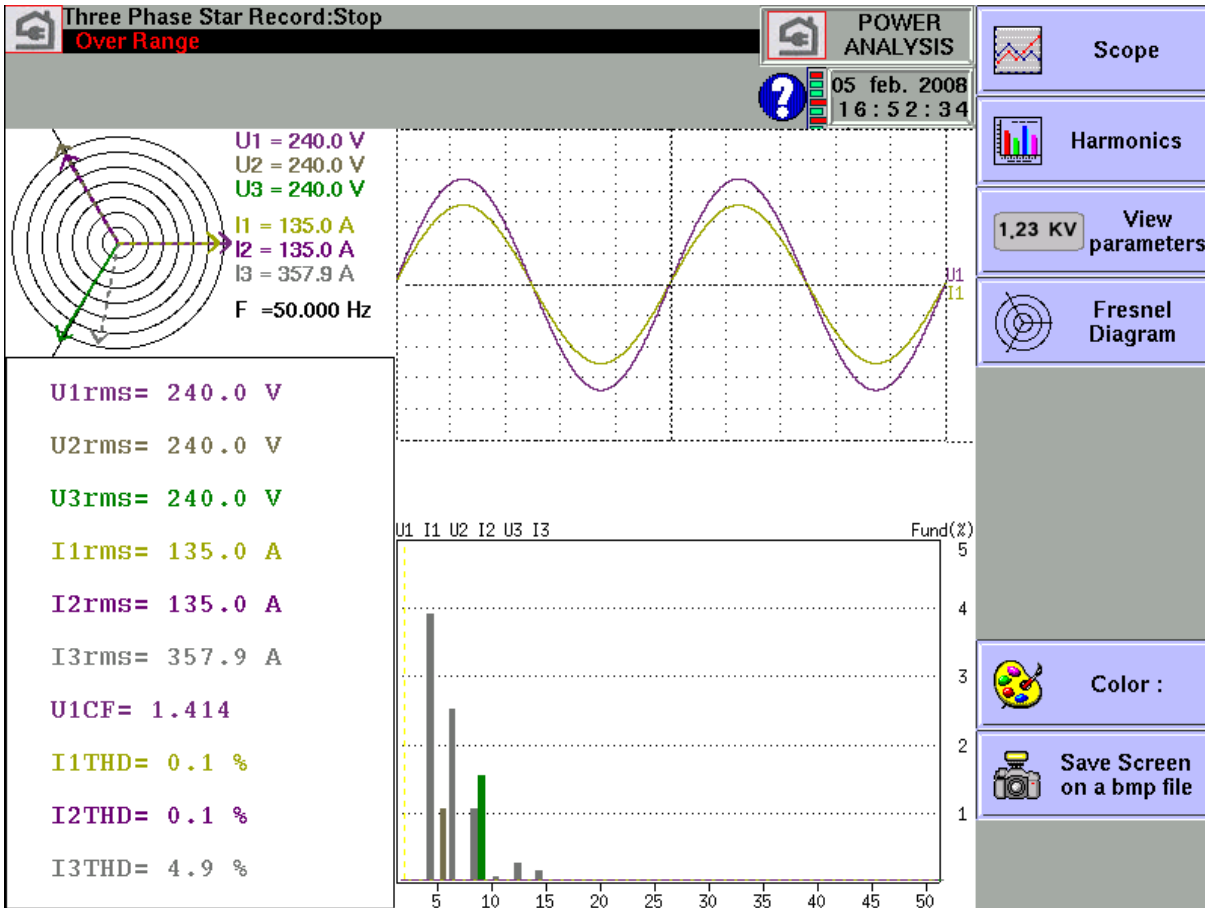

You can access this page even during acquisition.
Each of these windows can be disabled.

- ➔ **Fresnel Diagram:** display of the signal and of the RMS values of the various inputs and of the frequency (see the previous paragraph)
- ➔ **Oscilloscope:** This oscilloscope mode allows you to know the true shape of the signals, and this way helps you detect wiring mistakes.
 - The time basis is always the same: 4 ms/div
 - You can change the reticules and the position of the channels displayed
 - You can add other channels
 - The ratings that are used are indicative and do not meet the true values of the inputs.

- Harmonic Visualisation: This window is updated about 4 times per second.
- Selection of the channels: you select either every tension channels (U1,U2,U3) or every current channels (I1,I2,I3) or every network channels (U1,U2,U3 + I1,I2,I3), or only one channel
 - The sampling rate is 200 μ s
 - Number of points: 1024
 - In the case of only one channel, a cursor allows you to display the value of the selected harmonic.
 - A file can be record with each harmonics .
- Parameters: Display of the values of each defined parameter (see next paragraph)

At any moment, you can either copy the display into a bmp file, or print the page (only with a recorder without an internal printer).

12.1.3. Selection of the acquisition parameters: Menu "TRIGGER"

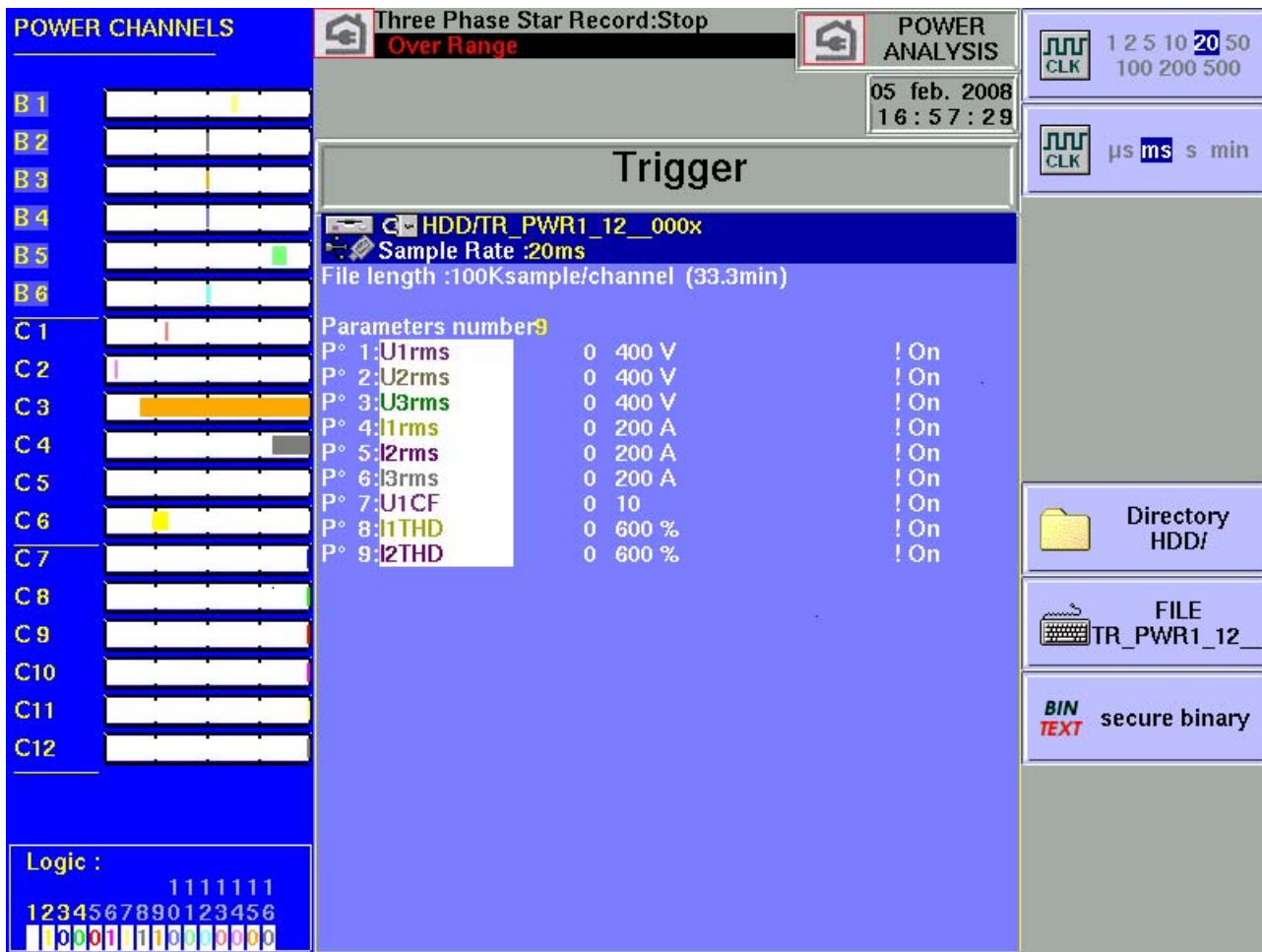

First, you specify the sampling period and the name of the file.

Contrary to the Memory mode, there is no trigger: as soon as you launch the record, the values of the parameters are recorded. You stop the data acquisition by pressing the F1 key in the acquisition page, or it stops automatically when the limit size of the file is reached.

- ➔ Number of observed values: You select it in "Number of parameters". The available values are between 1 and 24.
- ➔ Selection of the values: You can choose:
 - Tension and Current:

• RMS	rms:	RMS value
• Average	dc:	average value (DC shift)
• Peak	cr:	maximum value between the max and min peak values
 - Fond
 fond | fundamental value |
 - Peak factor
 fcf: | the peak factor is the ratio between the peak value and the RMS value (1.414 for a sinusoidal signal) |
 - Harmonic distortion rate THD:
 - characterises the total presence of harmonics in comparison with the fundamental component of the signal
 - Distortion factor DF:
 - characterises the total presence of harmonics in comparison with the true RMS value of the signal.

- Power:
 - P: Active
 - Q: Reactive
 - S: Apparent
- Energy
- FP: power factor ($\cos \phi$)
- Frequency: the calculation of the frequency is made at the U1 input
- Standard acquisition channel: you can select any available channel
- Logical input: only the last parameter can be configured this way.

In tension, current or power mode, you can choose each line (example U1,P2,I2) or the global value of the network (Ut,It,Pt)

For each parameter, you can change the following values:

- ➔ Validity: ON/OFF: allows to display a parameter as a graph, or not. The parameters will be recorded anyway: only the visualisation in graphical mode shall be affected
- ➔ Colour: it's the colour of the displayed parameter in the graph. For additional and logical channels, the colours are those already specified for each channel
- ➔ Rating: the rating is defined by the nominal values of tension and current, i.e. for a nominal tension of 230V, the rating will be 400V, centred around 200V (thus, between 0 and 400V). You may change the minimum and maximum values for a more accurate display. For example, you could display the signal U1 between 220V and 240V.

12.1.4. Acquisition

You start the data acquisition by pressing the "Record" key. The acquisition is made at the rhythm of the integration period. Then, the data are registered in a file.

During the acquisition, you cannot change the acquisition parameters, but you can change the display parameters (zoom, colour, validity of display, etc.)

You can also display the signals in scope mode or display the parameters in digital mode.

To stop the acquisition, you must press the menu-key "Stop".

If a mains failure happens during the acquisition, the registered file is conveniently closed. At the following power-up, a new acquisition will be made with possible opening of a new file.

12.1.5. Measurement methods

RMS values:
$$X_{rms} = \sqrt{\frac{\sum_{k=1}^N x_k^2}{N}}$$

Average values:
$$X_{mean} = \frac{1}{N} \sum_{k=1}^N x_k$$

Active power:
$$P = \frac{1}{N} \sum_{k=1}^N v_k * i_k$$

Apparent power:
$$S = U * I$$

Reactive power: $Q = \sqrt{S^2 - P^2}$

Power factor: $FP = \frac{P}{S}$

Peak factor: $F_c = \frac{X_{crest}}{X_{rms}}$

Distortion rate: $THD = \sqrt{\frac{X_t^2 - X_{fond}^2}{X_{fond}^2}}$

Distortion factor: $DF = \sqrt{\frac{X_t^2 - X_{fond}^2}{X_t^2}}$

Total active power: $P_T = P_1 + P_2 + P_3$

Total reactive power: $Q_T = Q_1 + Q_2 + Q_3$

Total apparent power: $S_T = \sqrt{P_T^2 + Q_T^2}$

Total tension: $U_T = \sqrt{\frac{U_1^2 + U_2^2 + U_3^2}{3}}$

Total intensity: $I_T = I_1 + I_2 + I_3$

Power factor: $FP_T = \frac{P_t}{S_t}$

Energy : $E_i = \sum P_i * T$

!! the maximum value of energy is $P_n * H$ with P_n =nomimal Power , H =12 Hours

13. FILE MANAGEMENT

13.1. General

For all possible types of files, the appliance has an internal hard disk and can admit an USB key, which makes it possible to:

- save and load the total configuration of the recorder
- save and load an acquisition.

The names of the configuration files are identified with a « *.CNF » extension.
The names of the acquisition files are identified with a « *.REC » extension.

You can create directories and save files into them.

Press the « **Create Directory** » key when suggested.

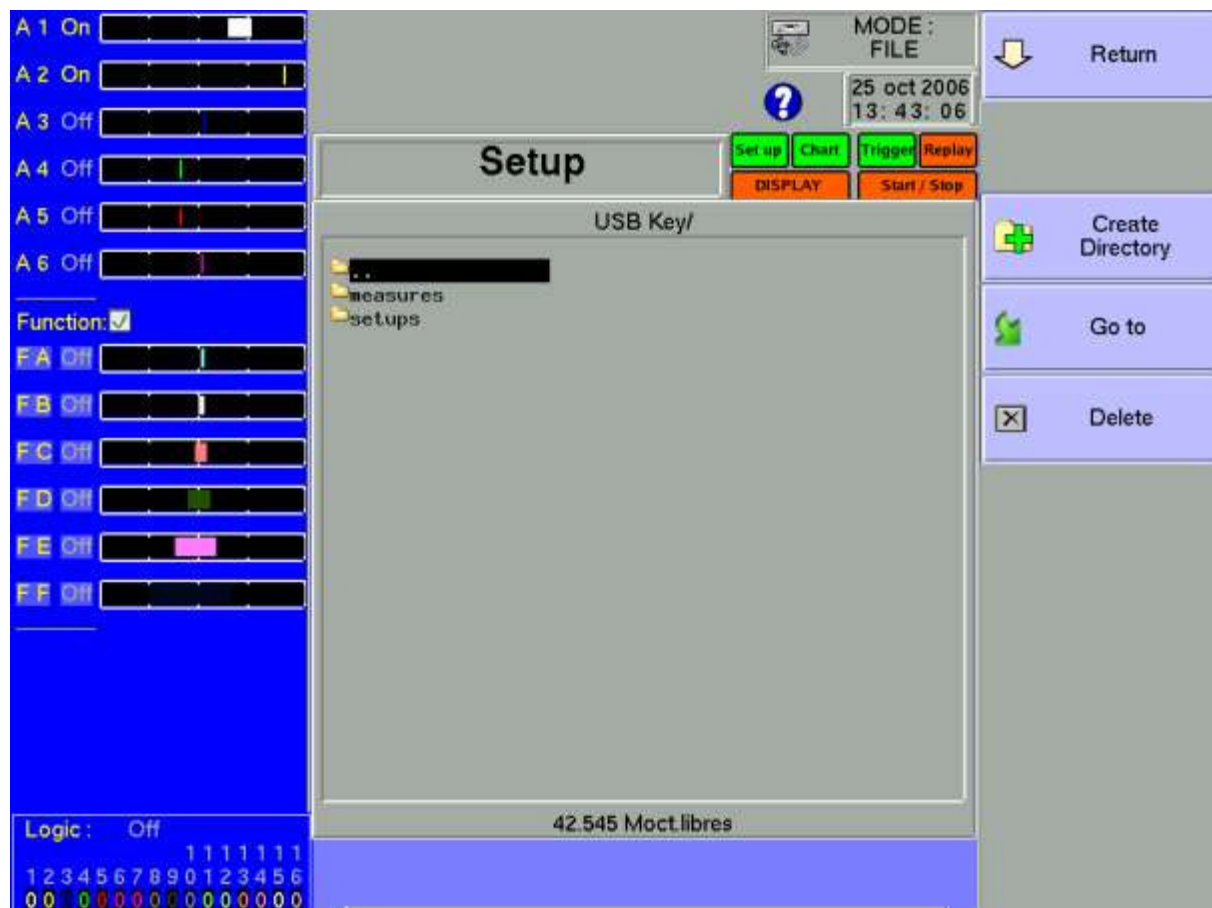

➔ **HD / USB key:** read / write on internal hard disk or USB key (if it has been connected at the power-up of the appliance)

➔ **Create directory:** creation of a directory; you can then enter its name thanks to an alphanumerical keyboard that is displayed on the screen

13 – File management

→ **Goto**: change of directory

→ **Delete**: deletes the selected directory



It is advised to work under a directory, and not on the root of the hard disk. It is easier for files organisation and for files deletion.
When you delete a directory, all file under this directory are deleted

13.2. Management of the configuration files

The management page for the configuration files is associated with the "Setup" key. Their name has a ".CNF" extension.

The screenshot shows the 'Setup' menu of a device. The interface is blue with white text. On the left side, there are six alarm status indicators (A1 to A6) and function keys (FA to FF). The main area displays 'Setup' with options for Language (English), Screen shut off (Waiting 30 mn), and Set Up (Alarm A: Trigger, Alarm B: Disabled, Alarm C: Disabled). At the bottom, it shows the IP address 135.150.010.049, Version 1.2.6, and No. Channels: 6. On the right, there are buttons for Reset, Memory Internal, Save On Disk, Load On Disk, and Print. The top right shows the date and time: 25 oct 2006 13:41:22.

→ **Reset**: initialisation of the appliance under standard configuration

→ **Internal memory**: saving / loading a configuration in internal non volatile RAM memory

→ **Save to disk**: saving a configuration into a file on the hard disk or an USB key

→ **Load from disk**: loading a configuration from a file on the hard disk or an USB key

13.2.1. Saving the configuration files

Press the « Save to disk » key

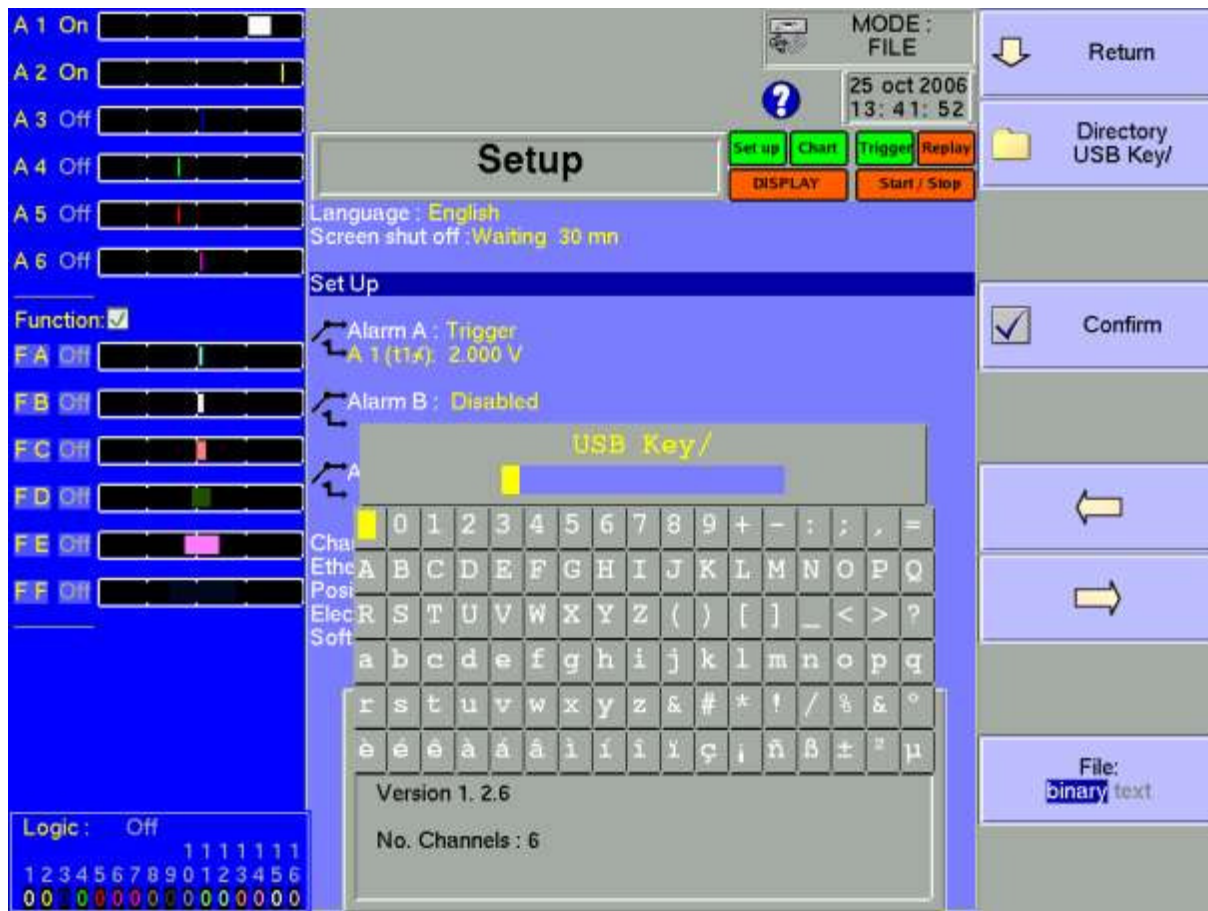

You can then enter the name of the file thanks to an alphanumerical keyboard that is displayed on the screen or thanks to an external PC-type keyboard if connected.

13 – File management

13.2.2. Loading the configuration files

Press the « **Load from disk** » key

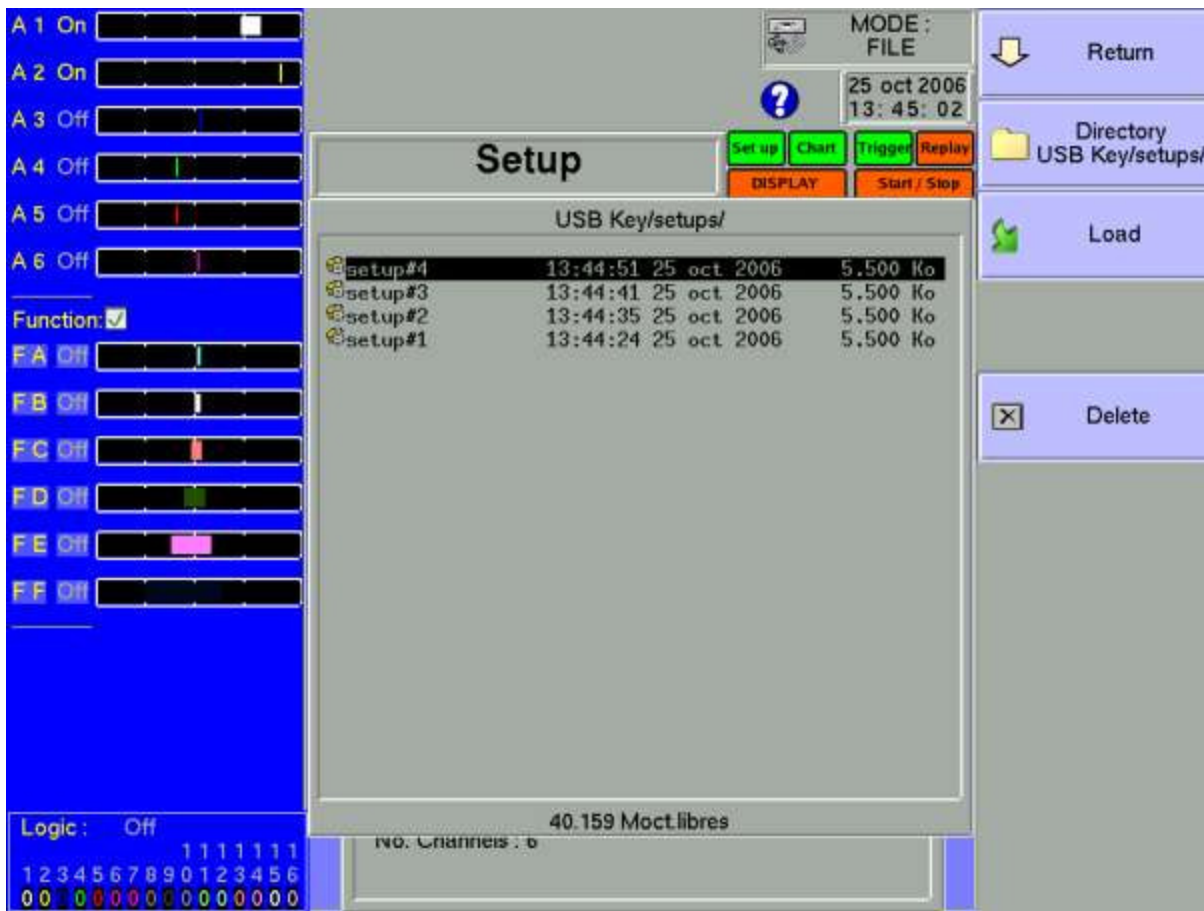

Select a directory then the file to load and click « **Load** ».



Attention: the current configuration will be lost

13.3. Management of the acquisition files

13.3.1. Saving the acquisitions

There are 2 ways for saving acquisitions into the appliance:

- in **Manual** mode after an acquisition
- in **Real time** mode during an acquisition.

Manual:

Available in any mode; you can access it with the « **Display** » functions after stopping the sweep and « **Memory output** » after pressing the « **Blocks and Files** » key.

Press then the « **Save to disk** » key , then write a name for the file and the destination directory.

Real time:

Available in **Direct**, **Memory** and **Go/Nogo** modes after validation of « **Saving Real time** » (the **File** mode is based on this real-time saving).

As soon as the recording is launched, the appliance saves the samples into the file. The file will be closed as soon as the acquisition is over.



If the acquisition is waiting for a start trigger, the appliance records into the file every dots before this trigger. After stopping the acquisition, this file will thus include more dots than the memory block that has been used for the acquisition.

In both cases, Manual or Real-time recording, the date of the file will be the closing date of the file.

Name of the files: the name of each file is made of 12 characters and a number made of 4 digits. The appliance will automatically increment this digit at each recording.

Only the validated channels (i.e. in **ON** position; see chapter **Use**) will be recorded into the file.

Before writing the file, an information window will remind you of the channels that will be saved and of the number of dots per channel.

The file is made of:

- a heading including the data required for later correctly loading the file (the configuration of each channel, the sampling rate, etc.)
- the N samples (1 sample = 2 bytes per channel).

13 – File management

13.3.2. Loading the acquisition files

Press the « **Load file** » key from the « **Replay** » function, then « **Blocks and files** ».



Select the place and the name of the file to load to display it on screen.

13.4. PC Software for analysis

Acquisition files can be transferred to a PC computer for analysis.

Viewer software is provided on a CD-ROM together with the appliance. It makes it possible to display the recorded files.

It works under WINDOWS XP, 2000, VISTA (with Framework 2.0)

Using the files on a PC is made in two times:

- transfer of the files to the PC thanks to the FTP protocol with your Internet navigator, for example
- display of the files thanks to the Viewer software.

13.4.1. File transfer with FTP

- Use of window explorer

This software is recommended because it is faster and the data are conserved..

Click tools then select connect a network

Click open a storage session or a network server

In internet network address put “ftp://address IP of my recorder”

address IP of my recorder can be for example: “135.150.12.2”

You can give a name to this network connection in “network favourite”

- Use of a navigator (internet explorer, firefox, opera etc..)

Launch your Internet navigator and write the connection address (see chapter **Setup**):

« **ftp://** » followed with the IP address of your recorder

then press « Enter » on your computer.

You can then access the directories of your recorder that include the acquisition files:

-HD: main directory on the internal hard disk of your appliance

After selection of the directory where you have recorded your acquisitions, you can rename, move, copy or delete them.

Transfer your files to your computer to use them with the provided Viewer software or FLEXPLO

13.4.2. Display with VIEWER software

Launch the VIEWER software.

Then open a .REC file

You can choose:

Channels to be displayed

The $f(t)$ or XY mode

Auto ranging of the channels

Your acquisition file will then be displayed on screen.

You will then take advantage of the functions of VIEWER.

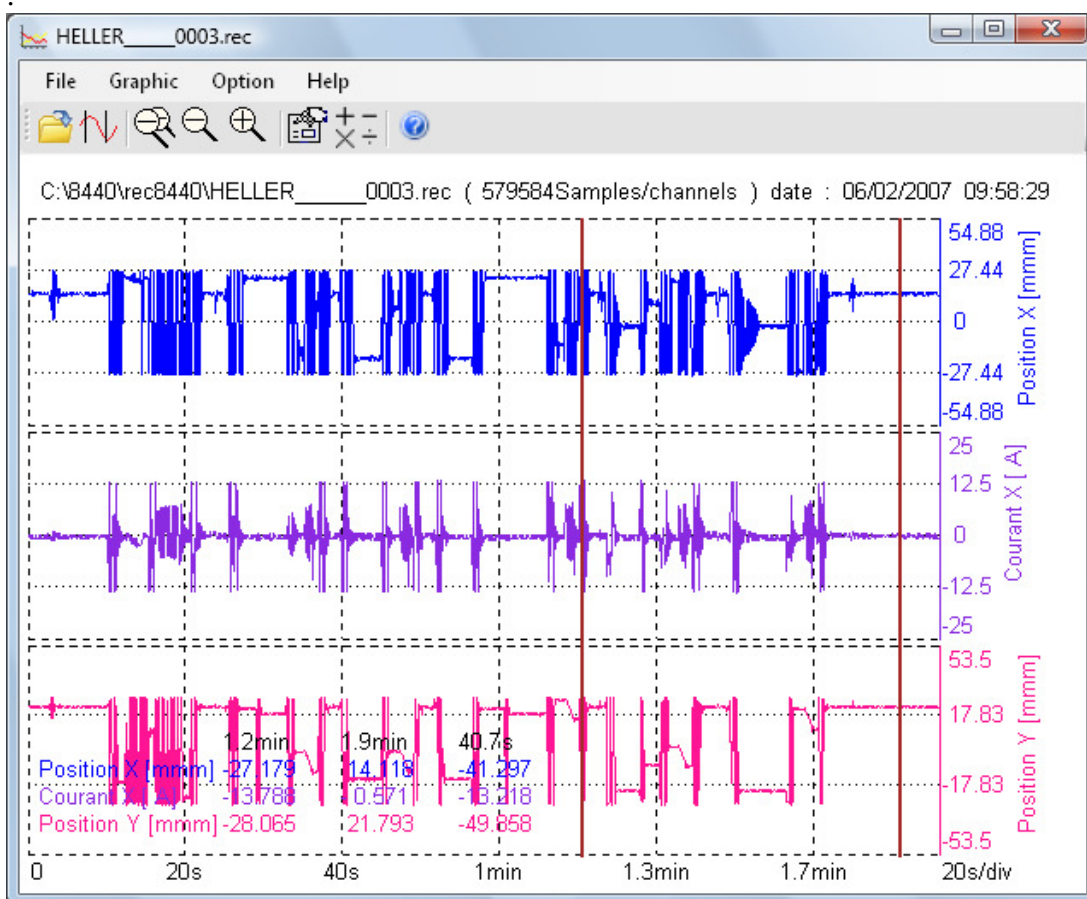

Use the user's manual included in the software to discover all the functions of VIEW by clicking the last icon « **Help** ».

You can directly create a result file (text or excel) by entering (in mode command of window: see help option) this command:

Viewer Myfile.rec /x

14. PRINTING WITH PAPERLESS RECORDER

This chapter details the direct printing function of the measurements on a local printer, connected to a paperless recorder.

You must connect your printer to one of the USB connectors.

You can print with the key « **Plot** » available from functions :

- « **Display** », key « **Setup Plot** » (scanning freeze)
- « **Replay** », key « **Setup Plot** »

14.1. Plot set up and launch

Press the key « **Setup Plot** », from « **Display** » ou « **Replay** » functions.

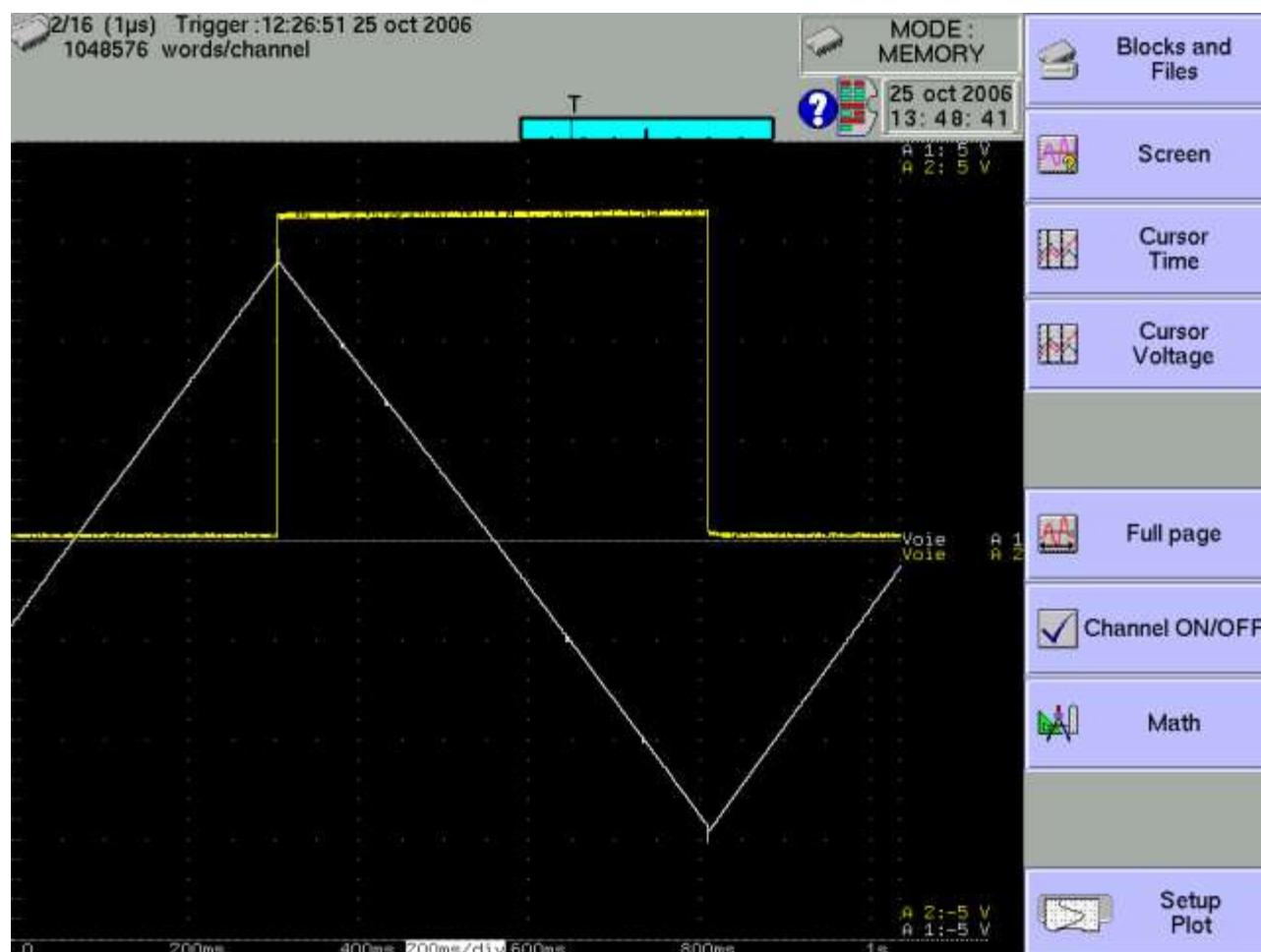

In « **Display** » function, the scanning must be freezed (key « **Freeze** ») to see this key.

In « **Replay** » function, a memory block or a file must be displayed on the screen to see this key.

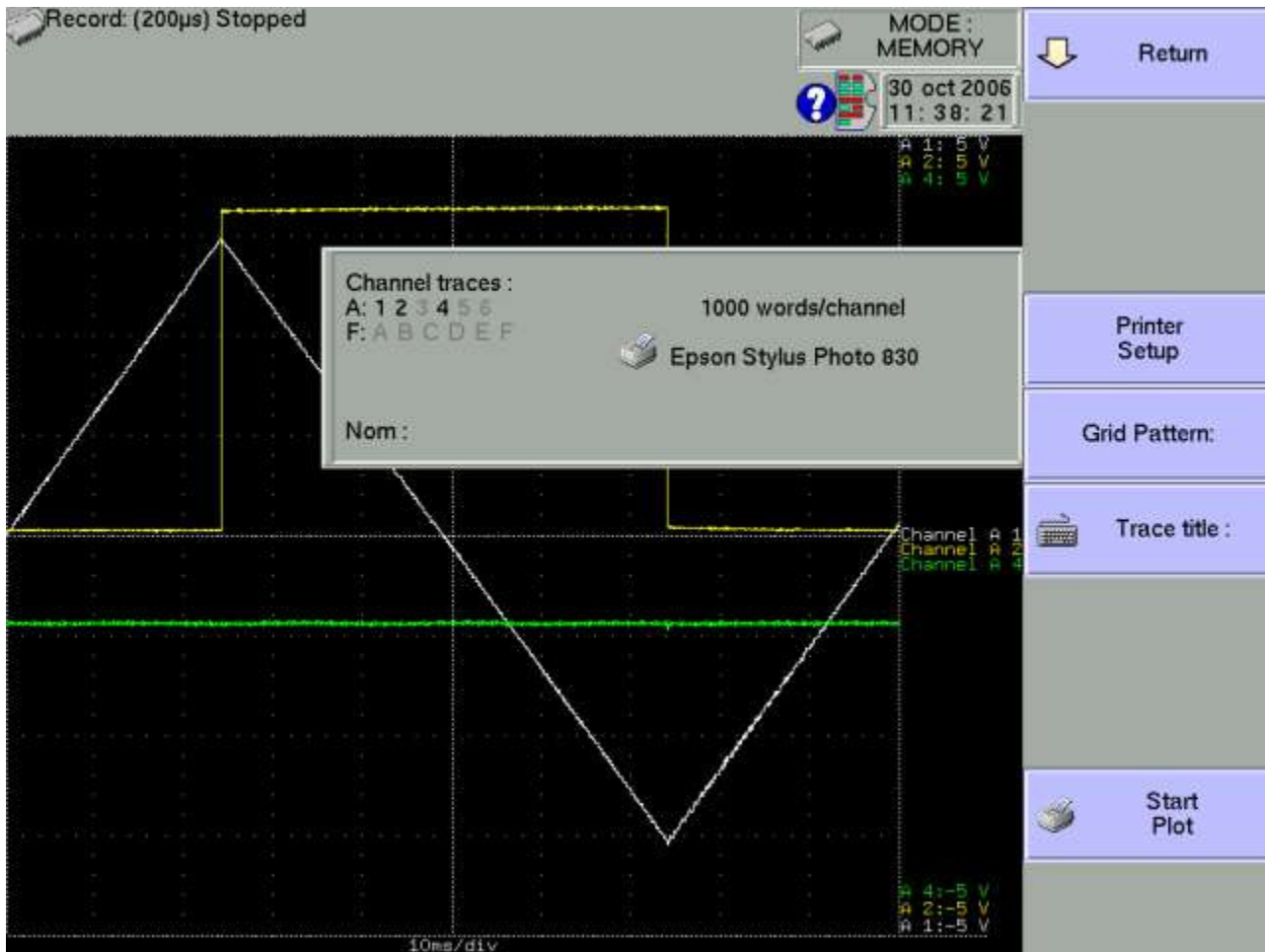

- ➔ **Printer Setup:** choose your printer into the list; see chapter « **Printer Setup** ».
- ➔ **Grid Pattern:** definition of the grid pattern plotted on the paper
 - none, every 5 mm, 10 mm or with an integer number of divisions
 - fine or wide, i.e. with or without subdivisions
- ➔ **Title:** giving a title (max. 124 characters) for printing. It will appear at the top of the paper sheet.
- ➔ **Colour :** choice of background and curves plotted colours
 - reverse or normal
- ➔ **Start Plot :** launch the printing

In **XY mode** the printed graphic is a screen copy

14.2. Printer Setup

The key « **Printer Setup** » launch an utility software to choose your printer inside the list of all the printers available in your recorder.

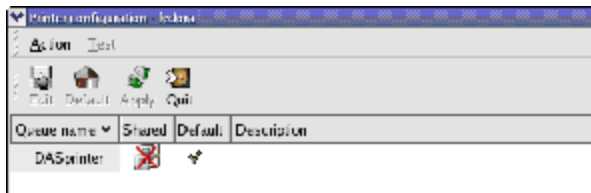

Highlight the default printer « **printer** » and hit « **Edit** ».

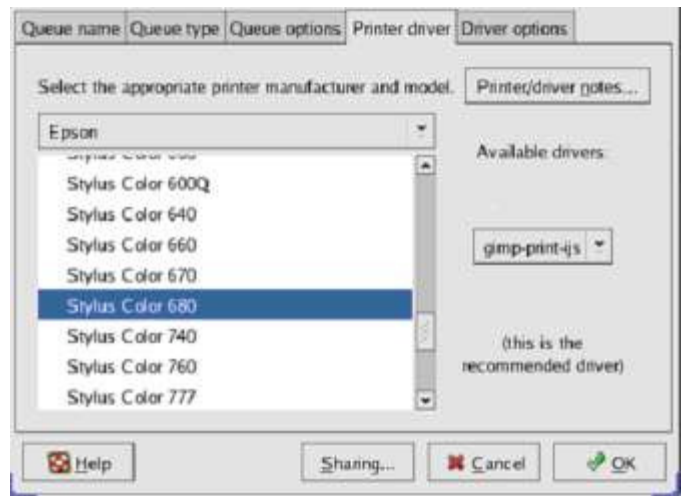

The software display several tabs for setting up the printer :

Hit the tab « **Printer driver** » for choosing your printer inside the list of all the printers available on your recorder .

Choose first the manufacturer and then, the type of your printer, and then hit the button « **OK** ».

You only need to hit the buttons « **Apply** » and then « **Quit** » to validate your modifications. So, your printer is installed and available for your printings.

If your printer don't appears in this list, you can choose another printer from the same manufacturer. The driver is very often the same.

(see http://openprinting.org/printer_list.cgi to verified if your printer is linux compatible)

For example , for the EPSON Stylus D68 you can choose the printer Stylus Color 680 (you can see than both use driver gim-print-ij)



You can reinit the printer queue in the page “setup”

15. INPUTS / OUTPUTS

15.1. Additionnal input / output connector

The connector is located at the rear (or at the top) of the appliance (male SUB-D 25-pin connector).

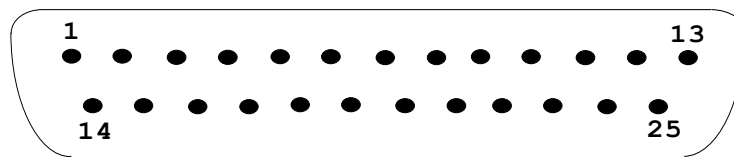

Pin no	Input or Ouput	Signal names
1	E	LOGIC CHANNEL 1
14	E	LOGIC CHANNEL 2
2	E	LOGIC CHANNEL 3
15	E	LOGIC CHANNEL 4
3	E	LOGIC CHANNEL 5
16	E	LOGIC CHANNEL 6
4	E	LOGIC CHANNEL 7
17	E	LOGIC CHANNEL 8
5	E	LOGIC CHANNEL 9
18	E	LOGIC CHANNEL 10
6	E	LOGIC CHANNEL 11
19	E	LOGIC CHANNEL 12
7	E	LOGIC CHANNEL 13
20	E	LOGIC CHANNEL 14
8	E	LOGIC CHANNEL 15
21	E	LOGIC CHANNEL 16
9		GROUND
10		GROUND
22		GROUND
23	S	POWER +12V, 0.1A
11		
24	S	CONTACT ALARM A1
12	S	CONTACT ALARM A2
25	S	ALARM B
13	S	ALARM C

The grounding of the power supply is the mechanical grounding of the housing of the SUB-D25.

15.2. Logical inputs

The non-connected inputs match the following circuit:

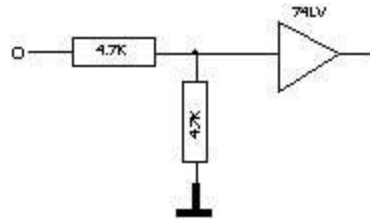

The non-connected inputs have a 0V-potential (level 0).

Number of logical channels: from 1 to 16

TTL level 3.3 V (protected until 24 V)

To create a rising edge, you only have to put a connection between the input and the 12 V power output of the connector.

Similarly, to create a falling edge, you only have to take away this connection.

You can also use a TTL 3.3 V output signal.

15.2.1. Use

Plotting and display:

These channels are plotted on the left or right side of the paper sheet according to the selected pattern.

They are displayed at the top or the bottom of the screen according to the selected position.

They are numbered from the right to the left.

Each of these channels are plotted between two dotted lines which represent the limits.

The height of the grid is minimum 2 mm for the plotting.

External clock:

You can use the channel 16 (pin #21 on the connector) for the paper feed in Direct mode or to synchronise the sampling of the channels in the other modes (Memory, GoNogo and File).

In Direct mode, The paper feed is made then with a 1/16mm step by the positive overrun of the TTL logical threshold of the channel 16.

The maximum frequency of the signal is 160 Hz, which corresponds with a 10mm/s paper advance.

In case of « Text » writing of the measures, the paper feed is made the same way. The transcription frequency is then limited to 1 Hz.

In the other modes, the acquisition can be made up to 500 kHz.

Triggering:

You can use the external channels to trigger the plotting and the acquisitions (begin or end).

See chapter « **Trigger** ».

15.3. Alarm outputs

Contacts and outputs are available on the rear side connector (A1 / A2), B and C.

The A1/A2 contact is a « dry contact » without any potential (24 V /100 mA).
The B and C outputs are TTL 5 V outputs.

When the appliance is voltage free, the A1/A2 contact is open and the B and C outputs have a 5 k Ω impedance.

15.3.1. Use

Indication of internal events to the outside and the recorder (triggers on the analogical or logical channels, status of the printing block...)

See chapter « Use », paragraph « Setup » key.

15.4. Power supply output

There is a +12 V power supply output limited to 0.2 A on the pin #23 of the connector.

The grounding of this power supply is the mechanical grounding.

So, you can use this output to provide power to a sensor or an electronic circuit in order to manage logical inputs.



The 12V supply may disappear in case of overload (> 0.2 A).
You should then turn off the appliance for a few minutes before turning it on again.

15.5. Keyboard input

Typical keyboard socket (mini DIN)



1	Data	+5V signal
2	NC	
3	Ground	0V
4	Power	+5V DC
5	Clock	+5V signal
6	NC	

15.6. Mouse input

Mouse socket (mini DIN)



1	Data	+5V signal
2	NC	
3	Ground	0V
4	Power	+5V DC
5	Clock	+5V signal
6	NC	

15.7. XGA screen output

XGA screen socket

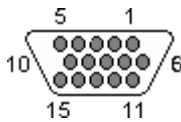

1	Red	
2	Green	
3	Blue	
4	Mon id (2) (IN)	
5	Ground	
6	Red ground	
7	Green ground	
8	Blue ground	
9	NC	
10	Sync ground	
11	Mon id (0) (IN)	
12	Mon id (1) (IN)	
13	H sync (OUT)	
14	V sync (OUT)	
15	NC	

15.8. RS232

Not used. Reserved to future applications.

15.9. USB Interface

USB interface socket



1	VCC	+5V power
2	Data-	Differential data-
3	Data+	Differential data+
4	GND	Ground

15.10. ETHERNET RJ45 interface

Ethernet RJ45 interface socket

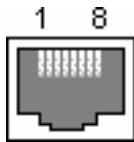

1	TX+	Tranceived data +
2	TX-	Tranceived data -
3	RX+	Received data +
4	NC	
5	NC	
6	RX-	Received data -
7	NC	
8	NC	

15.11. Extension box for digital input output

The extension box (PN 984405500) allow to :

Alternative voltage (example 230V 50Hz) conversion to digital signal 1

Easy connection of the 16 digital inputs

Isolation of the 16 digital inputs (250V \approx between channel, 250V \approx between channel and ground)

Easy connection of the alarm with screwed terminal

Supply of an external device with 3.3V or 5V or 12V with screwed terminal

Connection of digital input depending on the signal voltage :

0 to 250V \approx

black



connection 0 - 250V \approx digital input



red

With isolated banana plug black and red

Maximum voltage : 250V continuous or alternative

Frequency : 45 to 440Hz

Typical threshold (AC or DC): 48V

Non detected low level (AC or DC) : 0 to 10V

Detection high level (AC or DC) : 60V to 250V

Insulation : 250V \approx between channel and ground

15 – Inputs / Outputs

0 to 48V \approx

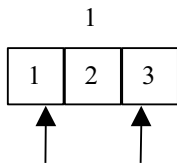

connection 0 - 48V digital input 1

With screwed terminal between pin 1 and 3

Maximum voltage: 48V continuous or alternative

Frequency: 45 to 440Hz

Typical threshold (AC or DC) : 9V

Non detected low level (AC or DC) : 2V

Detected high level (AC or DC) : 10V to 48V

Insulation : 50V \approx between channel and ground

0 to 10V \approx

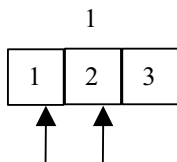

connection 0 - 10V digital input 1

With screwed terminal between pin 1 and 2

Maximum voltage: 10V continuous or alternative

Frequency : 45 to 440Hz

Typical threshold (AC or DC) : 2.2V

Non detected low level (AC or DC) : 1V

Detected high level (AC or DC) : 3V à 10V

Insulation : 50V \approx between channel and ground

Response time :

For alternative detection the signal of the digital channel is redressed and filtered: this introduce delay.

Typical delay time on rising edge : 10ms

Typical delay time o falling edge : 50ms

Operating :

Connect the box with the recorder using 25 wires cable delivered with the option

Connect the digital input with respect to the maximum allowed voltage

Supply / Alarms :

Ground	3.3V	5V	12V	Ground	Alarm A contact 1	Alarm A contact 2	Alarm B	Alarm C	Ground
1	2	3	4	5	6	7	8	9	10

3,3 V maximum current : 200mA

5 V maximum current : 200mA

12V maximum current : 200mA

Alarm A contact 1 et 2 : open contact when alarm, insulation 50Vmax with ground

Alarm B : digital output 0V / 5V non insulated

Alarme C : digital output 0V / 5V non insulated

16. ETHERNET INTERFACE

16.1. Interface Ethernet

16.1.1. Generality

You can use the recorder from remote thanks to its Ethernet interface and the TCP-IP protocol. Plug the recorder on your network with a straight cable on to the 10/100 BASE-T (RJ45) connector located at the rear of the appliance.

You can use the recorder on an Ethernet network 10 Mbyte/s or 100 Mbyte/s.

In case of a network using a BNC cable, you will have to use an external Hub to convert the BNC signal into RJ45 signal (use a straight cable).

If you only have a PC computer without a network, you can also use an ordinary-lay cable directly between the PC and the recorder.

Ordinary cable

Connecteur 1		Connecteur 2	
Pin	Signal	Pin	Signal
1	TX+	3	RX+
2	TX-	6	RX-
3	RX+	1	TX+
6	RX-	2	TX-

The recorder uses the TCP/IP protocol to dialog with the PC. You can then give an IP address with a sub-network mask.

Ask your network manager an IP address with the corresponding mask. After entry of the values, turn the appliance off and on to validate the new address.

If you don't have a network manager:

Check that the TCP/IP driver has been installed on your computer.

In the case of a PC with Win 95 or Win98:

Starting from the windows explorer, go to "Workstation", then "Configuration board", then "Network".

Check that the TCP/IP protocol has been installed, then check the IP address and the sub-network mask.

Make sure that your IP address and your mask are compatible with those of the distant computer. The recorder is using **Port 23**.

For example, in I mode, you could have:

PC	IP=192.135.20.00	mask = 255.255.255.0
Recorder	IP=192.135.20.01	mask = 255.255.255.0

See the definition of the classes of IP addresses.

Program:

You can create your own software under Visual Basic, Visual C++ or many other, for example by using the Winsock.dll driver by Microsoft.

You only have then to send to the appliance the orders as defined in the following paragraphs.

16.1.2.Using NTP

The use of NTP clock (network time protocol) permits to obtain an accuracy of the triggers better than 50 ms.

To install the recorder in your network it is necessary to define an IP address.

Display set up menu then choose Ethernet page.

Information are now available:

- IP address
- Gateway IP
- 2 IP DNS addresses (domain name system) . We are using OpenDNS address (208.67.222.222 et 208.67.220.220). but you can choose the DNS IP given by your IAP (Internet access provider)
- NTP server: use the universal NTP (default server is xx.pool.ntp.org) .

Visit the website to obtain more information: <http://www.ntp.org/> or <http://www.pool.ntp.org/>

It is possible to use an internal NTP server to your network or a close server.

Restarting the appliance permits to test if the appliance can communicate with the different systems.

Display the menu set up and choose Date.

2 choices are available: internal date or synchronised date (NTP). If you choose synchronisation, you may define the time zone and daylight .

For example Western Europe corresponds to GMT + 1 time zone. Great Britain is GMT+0

Restarting recorder permits a self-synchronisation on NTP server.

The date appears in red colour when the appliance is searching.

The date appears in blue colour when the synchronisation begins.

If the date remains in red colour, check the cables and the IP addresses in the Ethernet page.

Press the **TEST** key to test bonding.

16.2. Programming language

16.2.1. Format of the reception messages



In all the following examples, the <Space> character is represented by a blank space.

Exchanges from a captor to the recorder are made as messages made of a succession of ASCII characters (and possibly of binary bytes) with a termination sequence at the end of the message.

Syntax of a reception message

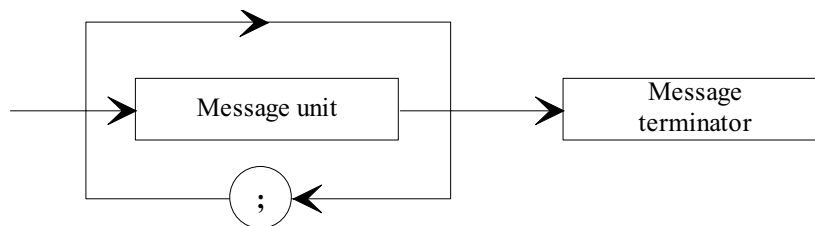

Message unit: is the message includes several message units, they are separated by a ";" and possibly preceded and/or followed by one or several "filling" characters in ASCII code (0 to 32, in decimal value except 10 and 13).

The message termination sequence (TERM) for the Ethernet link is :

- LF: Line Feed (10 in decimal)

The message termination sequence can be preceded by one or several "filling" characters in ASCII code (0 to 32, in decimal value except 10 and 13).

Example of messages made of 3 message units:

MESSAGE 1; MESSAGE 2 ; MESSAGE 3 TERM
CHANNEL 1; TYPE:VOLTAGE DC;:CALDEC ? TERM

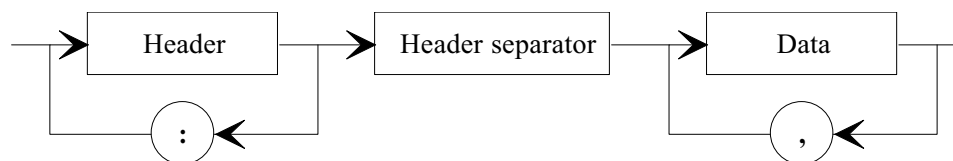

Syntax of a message unit

A message unit (for example: :REAR:SETUP 1) is made of several fields:

- Heading:

For the command messages (for example: **:REAR:SETUP 1**) or for the interrogation messages (for example: **:REAR ?**), it is made of a character chain (simple heading) or of several chains separated with ":" (composed heading).

A chain includes from 1 to 12 alphanumerical characters or the "_" character (code ASCII 95 in decimal). Advisable chain length: 4 characters.

A heading chain always begins with an alphabetic character. It may be preceded by ":" (composed heading) or end with an interrogation point "?" (interrogation message).



An interrogation message must always be followed by the termination sequence.

-Heading separator:

One or several ASCII characters (0 to 32, in decimal except 10 and 13).

-One or several pieces of data:

(for example: :SPEED 1,MM_S), alphanumerical, numerical or made of any characters or binary bytes.

-Data separator:

a comma ",", possibly followed and/or preceded by one or several "filling" characters in ASCII code (0 to 32, in decimal except 10 and 13).

Data:

There are several types of pieces of data:

-Alphanumerical data:

1 to 12-character ASCII-coded chains that can be alphabetical (lower or upper case), numerical or the "-" (95d).

The chain must begin with an alphabetical character.

For example, for a non-numerical parameter: SIM.

-Decimal digital data:

made of a mantissa and possibly of an exponent, and figured as a succession of ASCII-coded characters that begin with a digit or a sign (+ or -). It can be of NR1 (integer), NR2 (decimal) or NR3 type (with an exponent) or a combination of these three types.

- Text:

7-bit ASCII-coded character chain between quotation marks (") or apostrophes (').

For example: "Channel 1".

16.2.2.Format of the emission messages

The exchanges from the recorder to a control system are messages made of successions of ASCII characters (and possibly binary objects) ended with a termination sequence.

The format of the emission messages is identical with the format of the reception messages. However, its structure is more rigid.

The syntax of an emission message is: **Message unit + termination sequence**

Message unit:

If the message includes several message units, they will be separated by ";".

Termination sequence:

- RS232 link (selection in the Config menu):
 - CR: Carriage Return (13 in decimal)
 - LF: Line Feed (10 in decimal)
 - CR and LF.
- Ethernet link:
 - LF: Line Feed (10 in decimal)

Syntax of a message unit:

A message unit (for example: :TYP:THE J,COMP) is made of several fields

- *Heading:*

(for example :**TYP:THE**) made of one (simple heading) or several (composed heading) chains of 1 to 12 alphabetical characters (upper case only or digital or "_" (coded ASCII 95 in decimal)).

A heading chain always begins with an alphabetical character.

In a composed heading, character chains are separated with the ":" character (for example :TYP:THE).

- *Heading separator:*

"space" character (32d) only

- *One or several pieces of data:*

(for example: **J,COMP**) alphanumerical, digital or made of various characters or binary octets.

- *Data separator:*

A comma ",".

Data:

There are several types of pieces of data:

-*Alphanumerical data:*

1 to 12-character ASCII-coded chains that can be alphabetical (upper case only), digital or "_" (95d) (example **J**).

- *Decimal digital data:*

Made of a succession of ASCII-coded characters beginning with a digit or a sign (+ or -) It can be of NR1 (integer), NR2 (decimal) or NR3 type (with an exponent).

For example for a digital character: -25.02.

- *Text data:*

7-bit ASCII-coded character chain between quotation marks (") or apostrophes (').

For example: "A".

- *Any succession ASCII characters:* ends with the termination sequence.

16.3. Standard instructions

All these instructions begin with "*".

***IDN ?** REQUEST FOR IDENTIFICATION OF AN APPLIANCE

answer by the appliance: 4 pieces of data separated by ';':

- the trademark of the appliance
- the name of the appliance, followed by _nn where nn is the number of inputs of the recorder
- the serial number of the appliance (0 if unknown)
- the version number of the software: x.xx x

***OPT ?** REQUEST FOR IDENTIFICATION OF THE OPTIONS OF AN APPLIANCE

answer by the appliance: n pieces of data separated by ';':

- number of input modules
- number of channels per module

***RST** RESET OF AN APPLIANCE

action: initialisation of the recorder in a fixed configuration (voltage inputs, 10V range, 0V centre...)

***REM** SWITCHING TO PROGRAMMATION (REMOTE)

required in RS232C before sending any other programming command.

***LOC** SWITCHING TO LOCAL MODE

***CLS** DELETING THE STATUS REGISTERS

action: the appliance resets the status registers to zero.

***ESE** VALIDATION OF THE STANDART EVENT BITS OF AN APPLIANCE

*ESE is followed with a digit, from 0 up to 255

action: changes the validation register of the standard events and updates the ESB bit in the status register of the service request (see the following paragraph).

***ESE ?** INTERROGATION OF THE CONTENT OF THE VALIDATION REGISTER OF THE STANDARD EVENTS OF AN APPLIANCE

answer by the appliance: NR1 number between 0 and 255 (see the following paragraph).

***ESR ?** INTERROGATION OF THE CONTENT OF THE STATUS REGISTER OF THE STANDARD EVENTS OF AN APPLIANCE

answer by the appliance: NR1 number between 0 and 255.

All the events are deleted and the register is reset to zero (see the following paragraph).

***SRE** VALIDATION OF THE SERVICE REQUEST OF AN APPLIANCE

*SRE is followed by a number between 0 and 63 or between 128 and 191.

action: the appliance modifies the validation register of the service requests (see the following paragraph).

***SRE ?** INTERROGATION OF THE VALIDATION REGISTER OF THE SERVICE REQUEST OF AN APPLIANCE

answer by the appliance: NR1 number between 0 and 63 or between 128 and 191 (see the following paragraph).

***STB ?** READING THE REGISTER OF THE SERVICE REQUESTS OF AN APPLIANCE

answer by the appliance: NR1 number between 0 and 255: status byte with bit 6 MSS (Master Summary Status) (see the following paragraph).

16.4. Indication of the status of the appliance

16.4.1. Structure of the status data

This is the model of structure of the status data that allows you to learn the changes of status that occur in the appliance (power-up, starts of printing...).

Overall view of the structures of the status data of the recorder:

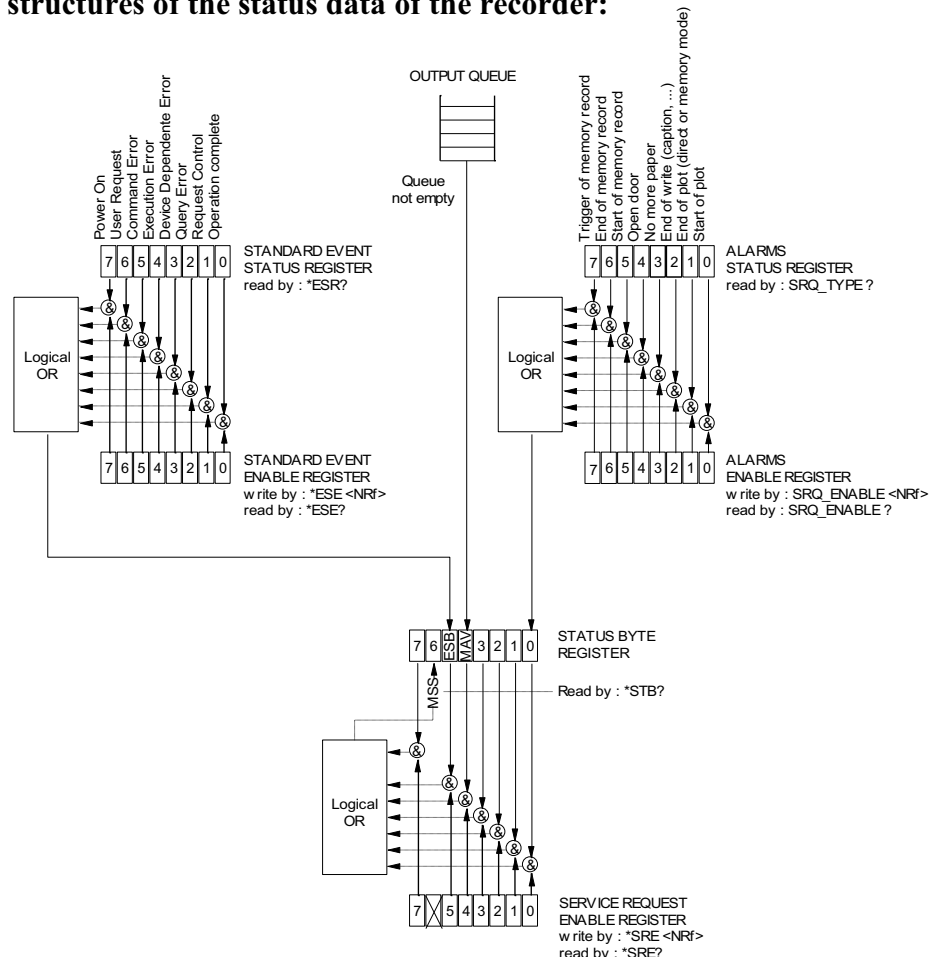

16 – Ethernet interface

4 registers are used:

- the service request register (STB) associated with its validation register.
 - the standard event register (Event Status Register - ESR) associated with its validation register.
- The bits #0, 1, 2 and 7 of the STB register are available for use as summarisation messages specific to the appliance. Each of these bits can be associated with a data structure whose model is defined and that manages the events in the appliance that may induce a service request.

The user can configure the recorder so that it loads the bit #6 of the service request register if some particular events should occur.

In RS232 configuration, the service request register has to be read regularly to detect an event. The identification of the event is made by reading the status byte, then the associated event register(s).

Status of these registers at power-up:

The content of the STB, ESR and alarm registers is systematically reset to zero at power-up (except the bit #7 of the ESR that specifies a power-up).

16.4.2.Registers of service request

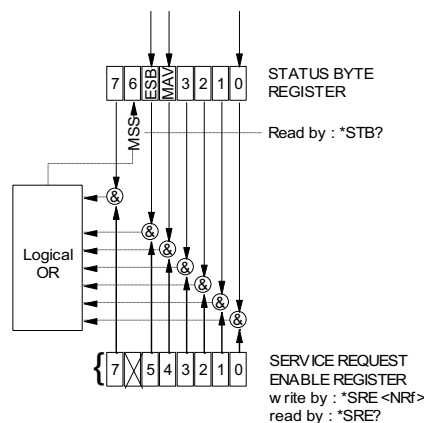

Status register:

It includes the status byte of the appliance.

This status byte can be read in case of interrogation with the "*STB?" instruction. In this case, the bit #6 is MSS (Master Summary Status) that comes from the logical operations as shown in the above figure.

In fact, MSS is equal to 1 when at least one other bit is equal to 1 both in the status register and the validation register.

Composition of the STB register:

The bit #6 (value 64) includes the recapitulative message "MSS" (reading with "*STB?").

The service request takes place in the following cases:

- a bit of the status register of service request switches from 0 to 1 while the corresponding bit in its associated validation register is 1, and vice-versa,
- the bit #5 of the validation register of service request is 1 and a standard event occurs in the following conditions:
 - a bit of the status register of the standard events switches from 0 to 1 while the corresponding bit in its validation register remains equal to 1

- a bit of the validation register of standard events switches from 0 to 1 while the corresponding bit in its status register is 1
- the bit #0 of the validation register of service request is 1 and a particular event occurs in the following conditions:
 - a bit of the status register of the alarms switches from 0 to 1 while the corresponding bit in its validation register is 1
 - a bit of the validation register of the alarms switches from 0 to 1 while the corresponding bit in its status register is 1.

The bit #5 (ESB: Event Status Bit, value 32) includes the recapitulative message of the status register of standard events (see the details of these bits in the description of this register). Its status shows whether one or several authorised events have occurred in the status register of standard events since its latest reset (an event is permitted if the corresponding bit in the validation register of events is 1).

The bit #4 (MAV: Message AVailable, value 16) includes the recapitulative message of the output queue. Its status shows whether a message or some data from the appliance are ready for sending via the interface (ex: answer to an interrogation instruction).

The bits #7 and 3, 2, 1, 0 are used to receive recapitulative messages defined by the appliance. In the case of the recorder, the bit #0 is used while the bits #1, 2, 3, 7 always remain at 0.

The bit #0 includes the recapitulative message of the status register of the alarms (see the details of these bits in the description of this register). Its status shows whether one or several authorised events have occurred in the status register of the alarms since its latest reset.

Validation register:

The status byte is associated with a validation register that makes it possible to control the service request and that allows only some cases.

When a bit is equal to 1, it makes it possible that the status 1 of the bit of same rank of the status register (STB) leads to the activation of the bit #6 in the same status register.

Writing into the validation octet is made by the *SRE<NRF> command, where <NRF> is the sum of the values of binary weights of the bits 0 to 5 and 7. *Reading* the validation octet is made with the *SRE? instruction. The answer is returned in decimal (NR1).

16.4.3.Registers of standard events

See the overview of the structures of status data.

The structure of the standard event registers is assigned to the bit #5 of the service request register.

Status register:

This register includes standard specific messages whose meaning is exposed thereafter.

You can read its content with the *ESR? command

Reading the register leads to its erasure.

The bits of the status register of the events are assigned to specific events:

* Bit 7: POWER-UP (value 128)

It shows that the power supply is on

* Bit 6: REQUEST FOR USE (value 64)

Not used, set to 0

* Bit 5: INSTRUCTION ERROR (value 32)

This bit shows that an unknown or incorrect instruction has been sent to the recorder

* Bit 4: EXECUTION ERROR (value 16)

Not used, set to 0

* Bit 3: ERROR FROM THE APLIANCE (value 8)

Not used, set to 0

* Bit 2: INTERROGATION ERROR (value 4)

This bit shows that the output queue is full and the data are or may be lost

* Bit 1: CONTROL REQUEST (value 2)

Not used, set to 0

* Bit 0: FINISHED OPERATION (value 0)

Not used, set to 0

An event is permitted only if the corresponding bit in the validation register of events is 1.

Validation register:

It allows you to control the status register of standard events:

When a bit of this register is 1, it makes it possible that the status 1 of the bit of same rank of the status register of standard events leads to setting to 1 the **bit #5** of the status register of service request (STB).

Writing into this register is made by the *ESE<NRF> command, where <NRF> is the sum of the values of binary weight of the validation register.

Reading this register is made with "*ESE?"

16.4.4. Register of the alarms

See the overview of the structures of status data.

The structure of the alarm registers is assigned to the bit #0 of the service request register.

Status register:

This register includes specific messages to the recorder whose meaning is exposed thereafter.

You can read its content with the SRQ_TYPE ? command

Reading the register leads to its erasure.

The bits of the status register of the alarms are assigned to specific events:

- Bit 7: MEMORY ACQUISITION TRIGGER (value 128)

This bit shows that the triggering condition for a memory acquisition has occurred

- Bit 6: END OF MEMORY ACQUISITION (value 64)

This bit shows that a memory acquisition is over

- Bit 5: BEGIN OF MEMORY ACQUISITION (value 32)

This bit shows that a memory acquisition has been launched

- Bit 4: Not used (value 16)

- Bit 3: NO MORE PAPER (value 8)

This bit shows that there is no more paper in the printer

- Bit 2: END OF WRITING (value 4)

This bit shows that a writing is over: cartridge, programmed text with the instruction WRItE (see programming dictionary)...

- Bit 1: END OF PRINTING (value 2)

This bit shows that a printing is over

- Bit 0: BEGIN OF PRINTING (value 1)

This bit shows that a printing has begun.

An event is permitted only if the corresponding bit in the validation register of events is 1.

Validation register:

It allows you to control the status register of the alarms:

When a bit of this register is equal to 1, it makes it possible that the status 1 of the bit of same rank of the status register of alarms leads to setting to 1 the **bit #0** of the status register of service request (STB).

Writing into this register is made by the `*SRQ_ENABLE <NRF>` where `<NRF>` is the sum of the values of binary weight of the validation register.

Reading this register is made with `"SRQ_ENABLE ?"`

16.4.5.Using the structure of status data

Before any use, you'd better send to the recorder the instruction `*CLS` that resets to zero all the status registers.

The user should first determine which events he wants to detect by allowing them in the validation registers:

- with the instruction `"SRQ_ENABLE n"` for events related to the alarm registers
- with the instruction `"*ESE n"` for events related to the standard event registers
- with the instruction `"*SRE n"` for events related to the service request register.

Example:

Programming a service request for: a start or a stop of paper-printing, an instruction error, the presence of data at the output of the recorder, are made with the instructions:

<code>SRQ_ENABLE 3</code>	(Bit 0 and 1 at 1)
<code>*ESE 32</code>	(Bit 5 at 1)
<code>*SRE 49</code>	(Bit 0, 4 and 5 at 1)

In RS232, the control system should regularly read the service request register with the instruction `"*STB?"`. The switching of the bit 6 (MSS) to 1 shows that an authorised event has occurred. The status byte that has been read makes it possible to determine the type of event that has occurred. In the case of a standard or specific event, the associated status register must be read with the `"*ESR?"` or `"SRQ_TYPE ?"` instructions to know precisely which event has shown up.

A standard event has occurred. The instruction `"*ESR?"` is sent:

Answer by the recorder: 160 (Bit 7 and 5 to 1)

Two events have been detected (power-up and instruction error) but only the instruction error (only authorised event in the validation register) led to the service request.

16.5. Programming dictionary

In the following tables, entering the lower-case characters of the headings and parameters is facultative.

As a rule, digital parameters are integers (NR1); those for which "in decimal" is specified can be of NR1, NR2 or NR3 type.

16.5.1.Setup

HEADER	PARAMETERS	EXAMPLES
MODE	P1 Defines the mode of using the instrument P1=DIRect, MEMory, FILE, GONoGo,POWer	MODE FILE
MODE ?	Returns current mode	
PAGe	P1 Display a screen on the LCD P1 = SETUP : setup CHAN : channel setup of CHANNEL TRigger : triggering CHArt: thermal paper setup SCOpe : direct display REPLay : replay memory display	CHAN A3;SCREEN CHAN Setup of channel A3
ALArm	P1 Defines the alarm to modify P1=A,B ou C	ALARM:VAL A,TR;TR:CH A1,S1,EDGE P
ALArm:DEF	P1 P2=NO,Trigger,RECtr or ERRor	the trigger is then defined by the message TRIG
ALArm ?	Returns alarms	
DATE	P1,P2,P3 Modify the date P1 = day (from 1 to 31) P2 = month (from 1 to 12) P3 = year (from 0 to 99)	DAT 11,12,08 december 11, 2008
DATE ?	Returns the date	
HOUrs	P1,P2,P3 Modify the current hour P1 = hour (from 0 to 23) P2 = minute (from 0 to 59) P3 = seconde (from 0 to 59)	HOURS 10,6,0 10 Hours and 6 minutes
HOUrs ?	Returns the hour	
RECAI	P1 Recall a setup P1= Number of the setup	RECA 3 Recall setup #3
STORe	P1,P2 Store a setup P1= Number of setup P2= Name of the setup (between " or ')	STORE 2,"setup2" Storage setup #2 with name "setup2"
READSETup	Returns data from the current setup (binary) the instrument send 4 bytes which is the number of bytes that will be sent then 2 bytes which is the checksum of the setup file then all the bytes of the file	
SENDSETup	Send a setup to the recorder (binary) same format to message READSETup	
CAPtion	Thermal paper caption writing	
KEYBlock	P1 Block the keyboard (ON or OFF)	

16.5.2.Parameters of the channels

HEADER	PARAMETERS	EXAMPLES
CHAnnel	P1 Defines the CHANNEL to be modified by the following commands P1 = channel choice (A1,A2, etc...)	CHAN B3 A modification of the channel 3 of the board B has been chosen
CHAnnel ?	Returns the selected channel number and its value	
VALID	P1,P2 Defines the channel validity P1 = ALL for all the channels A1,A2, etc... For each channel LOG for logical channels P2 = ON or OFF	VALID ALL,OFF;CHAN A1 ON;CHAN ----- Valid channel A1 and logical channels
VALID ?	Return sthe validity of all the channels	
NAME	P1 Modify the CHANNEL name P1 = name (maximum 26 caracteres) beetween " or '	CHAN B3;NAM 'oven1'
NAME ?	Returns the CHANNEL name	
TYPe:VOLtage	P1 Modify CHANNEL type to voltage P1= DC ,RMS DVDT SVDT	TYPE:THERM K,COMP Use of a compensated thermocouple K
TYPe:SHUNT	P1,P2 Modify CHANNEL type to current shunt P1 = DC or RMS P2 = S1M,S10M,S01,S1,S10,S50 (for 1mOhm, 10mOhm ,0.1 Ohm, ... 50 Ohm)	
TYPe:FREQ	Modify CHANNEL type to frequency	
TYPe:PT100	P1,P2 Modify CHANNEL type to PT100 P1= W2, W3, W4 for 2 wires, 3 wires or 4 wires P2= Resistor value (in 1/10 of ohms)	
TYPe:THErmo	P1,P2 Modify CHANNEL type to thermocouple P1= Thermocouple = J,K,T,S,B,E,N,W	
TYPe:GAUge	P1,P2 Modify Channel type to Gauge P1=HALF , FULL P2=2V or 5V P3= vary from 1.8 to 2.2	
TYPe:INTEGRE	P1,P2 modify channel type to integration or derivation P1= range of channel (in volt) P2=periode of integration (in seconde)	
TYPe:COUNter	P1 modify channel type in counter P1 : threshold of the channel 'in volt)	
TYPe ?	Returns the type of CHANNEL	
UNIt	P1 Temperature unit for types thermocouple and PT100 P1: CEL,FAR,KEL	UNIT CEL Unit Celsius degree
UNIt ?	Returns the temperature unit of CHANNEL	

16 – Ethernet interface

HEADER	PARAMETERS	EXAMPLES
FILter	P1 Defines the filter of CHANNEL P1 = WOUT,F10KHz,F1KHz,F100Hz,F10Hz, F1Hz,F10S,F100S or F1000S	FILTER 10HZ
FILter ?	Returns the filter of CHANNEL	
RANge	P1,P2,P3 Modify the range and the center (zero) of CHANNEL P1 = range in ISO unit (Volts or °C) in real number P2 = center in ISO unit in real number P3 = Position in %	RANGE 12,3,0 range = 12 Volts center = 3 Volts
RANge ?	Returns the range and the center of CHANNEL	
THREshold	P1,P2,P3 Defines the thresholds P1=S1 or S2 P2=ON or OFF (plotting threshold) P3=Value of threshold	:THRES S1,ON,10 threshlod S1 is 10 Volts
THREshold ?	Returns values of the 2 thresholds of CHANNEL	

16.5.3.Functions of the channels and between the channels

HEADER	PARAMETERS	EXAMPLES
FUNCMATH	P1 Select a mathematical function for CHANNEL P1 = Type of function : NONE, UNIT, AX, ABSX, SQRX, SQROOTX, LOGX, EXPX,AINVX,ADVDT,AINTV (without, change unit, ax+b, a x +b, ax ² +b, ...)	CHAN 2;FUNCTION LOGX; channel 2 is aLog(x)+b
FUNCMATH ?	Returns the function of CHANNEL	
COEFF	P1,P2 Defines the function coefficients P1 is A, B ,C or X1,X2,Y1,Y2	:COEF A,2;COEF B,0 A is 2 B is zero
COEFF ?	Returns coefficients values of the function of CHANNEL	
UNITFunction	P1 Defines the unit of the function P1 = name of the unit (max 6 caracteres) beetween " or '	UNITF 'DB'
UNITFunction ?	Returns the function unit name	
FUNCXY	P1,P2,P3 Defines the function beetween channels F(X,Y) P1= first channel (from A1 to FF) P2= Operator PLUS,MINUS,MULT,DIV P3= second channel (from A1 to FF)	CHAN FB;FUNCXY A1,PLUS,A2
FUNCXY ?	Returns the function	
RDUnit	P1 Select the measurement unit : P1: ISO channels unit NORM : normalized unit from 0 to 10000	RDU ISO;ONOFF ALL,OFF;ONOFF A1,ON;ONOFF A3,ON;RDU ISO;DRC ?
FUNCTION	P1 Validity of functions P1=ON or OFF	
FUNCTION ?	Returns validity of functions	

Load values:

HEADER	PARAMETERS	EXAMPLES
RDC ?	Returns values of all channels and logic channels value (or Parameters if Power analyser)	

16.5.4.Chart

HEADER	PARAMETERS	EXAMPLES
DIRECTPLOT	P1 Defines the plotting mode on paper P1 = FT, TEXTe	DIRECTPLOT FT F(t) mode in real time has been selected
DIRECTPLOT ?	Returns the plotting mode on paper	
SPEed	P1,P2 Paper speed definition P1 = speed value : 1,2,5,10,20 for P2 = MM_H ou MM_M, 1,2,5,10,20,25,50,100,200 for P2 = MM_S P2 = units MM_S (mm/second) MM_M (mm/minute) MM_H (mm/hour)	SPEED 10,MM_S Speed of 10 mm/sec
SPEed:LOGEXT	P1 : impuls/mm External paper speed definition	
SPEed ?	Returns the command status of SPEED or SPEED:EXT	
BASESPeed:NONE	Base speed equals zero	BASESP:SPE 1,mm_H
BASESPeed:SPEed	P1,P2 Allow to modify paper speed before trigger P1 = speed value (see SPEED) P2 = Unit (see SPEED)	Speed before trigger 1mm/hour
BASESPeed ?	Returns paper speed before trigger	
TEXTSpeed	P1,P2 Defines the writing period in text mode P1 from 1 to 500 P2 is Sec, MIn or HOurs	TEXTSPEED 2,SEC
TEXTSpeed:EXT	Defines the external writing period	
TEXTSpeed ?	Returns writing period in text mode	
GRATicule	P1,P2 Defines the paper grid P1=WOUT,G5,G10 or DIV defined the kind of grid P2=Fine or Coarse	GRAT G5,C
GRATicule ?	Returns the command	
CHART:TITle	P1 Defines the acquisition title P1 =message beetween '	CHART:TITLE "OVEN 12"
CHART:TITle ?	Returns the acquisition title	
CHART:DATe	P1 Defines the paper datation P1 = ABSolute or RELative	CHART:DAT ABS
CHART:DATe ?	Returns the command	
CHART:BOUndary P1	P1 Defines the writing boundaries at the end of the plot P1 = WITH or WOUT	CHART:BOU WITH Ecriture des bornes
CHART:BOUndary ?	Returns the command	
ANNOTE	P1,P2 Defines the annotation mode P1 = WOUT,START,ALarm or LENgth P2 is the number of alarm (from 1 to 3) or the paper length	ANNOT LEN,20 Annotation every 20 cm
ANNOTE ?	Returns the command	
ANNOTE:TYpe	P1,P2,P3 Writing of names of channels P1 = NONAME or NAME writing channels names P2 =NONUMber or NUMber writing channels numbers P3=NO,VALue,RANge,SCALE MINmax definition of type of annotation to write	ANNOT:TYpe NAME,NUM,VALUE
ANNOTE:TYpe ?	Returns the command	
ANNOTE:BMP	P1 Plot a bmp file P1=WITH or WOUT	You can change the file with ftp

16.5.5.Triggerings

HEADER	PARAMETERS	EXAMPLES
START:MANual	Manual triggering (start or stop)	START:MANUAL
START:TRIG	Complex thresholds triggering	start:trig::trig:chan A1,S1,POS
START:WAI t	P1,P2,P3 Awaiting delay triggering P1 = number of hours to wait (0 to 23) P2,P3 = minutes,secondes (0 to 59)	START:WAIT 0,2,10 awaiting 2min10sec
START:DATE	P1,P2,P3,P4,P5,P6 Date triggering P1 = day (from 1 to 31) P2 = month (from 1 to 12) P3 = year (from 0 to 99) P4 = hour (from 0 to 23) P5,P6 = minute,seconde (from 0 to 59)	START:DATE 3,10,06,15,30,10 start at 3/10/06, 15:30:10
START:AUTO	Automatic triggering (not in DIRECT mode)	
START ?	Returns the start triggering condition	
STOP:MANual	Manuel stop (DIRECT mode only)	
STOP:TRIG	Complex thresholds triggering	
STOP:WAI t	P1,P2,P3 Awaiting delay triggering (see START:WAIT) (only in DIRECT mode)	
STOP:DATE	P1,P2,P3,P4,P5,P6 Date triggering (only in DIRECT mode)	
STOP:LENGTH	P1 Paper length triggering P1 = paper length en dozen of cm (only in DIRECT mode)	
STOP:AUTO	Automatique stop (MEMORY mode or FILE mode)	
STOP ?	Returns the stop triggering condition	

16.5.6.Triggers

HEADER	PARAMETERS	EXAMPLES
TRIG:TYP	P1 P1=EDGE or LEVEL	
TRIG:LOG	P1 Defines the logic channels trigger P1=16 bits trigger values between "	TRIG:LOG "XXXXXXXXXXXXXXXXX1" triggerinf on Logic Channel VL1
TRIG:Chan	P1,P2,P3 P1=Number of the channel (A1,A2 etc...) P2=Threshold (S1 ou S2) P3=POS or NEG for rising edge or falling edge	TR:CH A1,S1,EDGE P triggering on rising edge of channel A1 (threshold 1)
TRIG:COm	P1 Defines the complex trigger P1=OR, AND or DELta which is : one of the thresholds (OR) all the thresholds (AND) slope (DELta)	TRIG:CO DEL;CO:DEL 2,S;RESET; ADD A1,S1,POS; ADD A2,S1,NEG We have 2 thresholds : S1 on A1 and S1 on A2
TRIG:COm:DELta P1,P2	P1,P2 Defines the slope P1 = value (from 1 to 500) P2 = Sec or MIN or HOURS	
TRIG:COm:REset	reset trigger : delete all conditions	
TRIG:COm:ADD	P1,P2,P3 Add a threshold to the trigger P1=Number of the channel (A1,A2 etc...) P2=Threshold (S1 or S2) P3=POS or NEG for rising edge or falling edge	
TRIG ?	Returns the value of pointed trigger	



The trigger that you have to program depends on the latest command sent (alarm, trigger start, trigger stop, etc.)

16.5.7.Memory/File mode

HEADER	PARAMETERS	EXAMPLES
MEMSpeed	P1,P2 Defines the sampling period P1 = Period (from 1 to 500) P2 = MICro,Mlli,Sec,Min or HOur unit	MEMSPEED 10,MICRO Period of 10 µsec
MEMSpeed:EXT	External clock using	
MEMSpeed ?	Returns the sampling period	
MEMBloc	P1 Defines the number of blocks P1 = 1,2,4,8,16..128	MEMBLOC 4 4 blocks
MEMBloc ?	Returns the number of blocks and the validity of them	:MEMBLOC 4,2 : we have 4 blocks with 2 valid blocks
POSTrig	P1,P2 Defines the triggering position within the record P1 = from -100 to +100 in % P2 = ON, OFF ; disable trigger while pretrigger	:STOP:AUTO;POSTRIG 0 Record after triggering
POSTrig ?	Returns the triggering position	
MEM:CONT	P1,P2 Defines the action after recording P1 = PLOt ,NOPlot : plot or not P2= File ,NOFile : file save or not	
MEM:CONT ?	Returns the action after recording	
FILE:NAME	P1,P2 Name of the file to save P1=BINary,TEXTe : file format P2 : name of file (max 12 caracteres)	:FILE:NAME BIN,"FileO";LENG LIM;LENG:LIMIT 10,MS
FILE:NAME ?		
FILE:LENGth	P1,P2 Defines the file size limit P1=from 0 to 1000 (0=no limit) P2=KSample or MSample	
FILE:LENGth ?	Returns the file size limit	
FILE:PRETR	P1 Pretrigger (only in file mode) P1 =0 to 100 (Ksamples)	

16.5.8.Reloadings, real-time savings

HEADER	PARAMETERS	EXAMPLES
REARm	P1 Defines the rearming P1 = SINgle,AUTo,SETup	REARm SINGLE
REARm:SETup	P1 Number of setup to load P1 = 1 à 15	REARM SETUP;REAR:SETUP 2 Load setup 2
REARm ?	Returns the kind of rearming	
SAVE	P1 Real time saving in file P1 = NO, DISK or MEMORy NO : no file DISK : save on HDD or USBKey MEMORy (only in DIRECT mode)	SAVE DISK
SAVE ?	Returns the kind of real time file save	
SAVE:MEM	P1,P2 Defines the triggering of memory record in DIRECT mode P1= DIRect,TRIG or MANual P2=CONT,NOCont : rearming	SAVE MEM;SAVE:MEM TRIG,NOC;:TRIG:CHAN A2,S1,POS
SAVE:MEM ?	Returns the kind of memory triggering in DIRECT mode	

16.5.9. Launching plotting and recording

HEADER	PARAMETERS	EXAMPLES
RECORD	P1 Start or Stop of plotting in DIRECT mode, or recording in other modes. P1= ON : start OFF : stop TRIG: forcing of trigger TRIGREC : forcing of memory trigger in DIRECT mode	RECORD ON In DIRECT mode, the plotting will began after start trigger is true The triggering can be forced with RECORD TRIG for start and RECORD OFF for stop
RECORD ?	Returns the command and the ratio of the MEMORY recording	
WRITE	P1 Immediat writing of the message on the paper In File mode allowed to do an annotation P1 = message (max 93 characters) between " or '	WRITE 'RECORDER'
LINE	plot a vertical line	
TEXT	P1,P2 Immediat writing a horizontal text at poistion P1 P1: position (in millimeter) P2 : message 'max 50 characters)	

16.5.10. Diagrams

HEADER	PARAMETERS	EXAMPLES
GRID	P1,P2 Defines the diagrams P1 = Number of diagram P2=SEPLOGON ou SEPLOGOFF : separated logic channels or not	GRID:LOG 50,5,UP;;GRID 2,SEPLOGON Logic channels are at the top, with height of 50 mm. We have 2 diagrams of 100 mm each.
GRID ?	Returns the definition of all diagrams	
GRID:LOG	P1,P2,P3 Defines the diagrams for logic channels P1=Number of logic channels P2=Heigh of logic channels P3=UP or DOWN : position of logic channels	
GRID:LOG ?	Returns the definition of logic diagram	
GRID:LENGth	P1,P2,P3 Defines each diagram P1= number of the diagram P2= min value (0 to max) max is 250 or 200 (depend of instrument) P3= max value max (0 to max)	GRID:LENG 1,0,100 Diagram 1 from 0 to 100mm
GRID:LENGth ?	Returns the definition of diagrams	
GRID:CHAnnel	P1,P2,P3 Defines the position of a channel P1= Number of the channel P2= Number of diagram : from 1 to Max P3= drawing thickness : 1 to 8	GRID:CHA A4,3,2 Channel A4 in diagram 3 with a width of 2
GRID:CHAnnel ?	Return the definition of CHANNEL	
COLOR	P1,P2,P3 Color of CHANNEL P1 = red value (from 0 to 100) P2=green value P3= blue value	CHAN A2,COLOR 100,100,100
DEFLOG	P1,P2,P3,P4,P5 Defines logic channels P1= Number of the logic channel P2= red value (from 0 to 100) P3= green value P4= blue value P5= Name of the logic channel	

16 – Ethernet interface

16.5.11. Direct display

HEADER	PARAMETERS	EXAMPLES
SCREEN	P1 Defines the visualisation mode P1 is FT, TEXT or XY	SCREEN FT
SCREEN:FT	P1,P2,P3 Defines the F(T) mode P1:VER or HOR : vertical or horizontal P2:BOUNON ou BOUNOFF : display boundaries or not P3:FULLON ou FULLOFF : full screen display or not	PAGE SCOPE;SCREEN FT;;SCREEN VER,BOUNON,FULLON Vertical display, full screen
SCREEN:XY	P1,P2,P3 Defines the XY mode P1=channel X is A1,A2, etc... P2= channel Y is ALL for all valid channels, or A1,A2,...for a single channel P3= DOT,VECTOR	SCREEN:XY A3,A2
SCREEN:TIMEBASE	P1,P2 Defines the time base of scope mode P1 = value (from 1 to 500) P2 = MLLisec, Sec, Mln or Hours : unit	SCOPE:TIMEBASE 500,MS;;SCREEN FT;;PAGE SCOPE;;SCOPE:RESTART
SCREEN:RUN	P1 Start or Stop the scope display P1=ON or OFF Start/Stop the scope display	change time base and then display scope screen in f(t) mode
SCREEN:RUN ?	Returns scope display mode	
SCREEN:TRIG	P1,P2,P3,P4 P1 : channel P2:=POS,NEG : edge P3: Threshold (0-100) P4: position (0-10)	

16.5.12. Mathematics functions

HEADER	PARAMETERS	EXAMPLES
MATH	P1 Number of mathematic function P1 is FT, TEXT or XY	MATH 3
MATHDEF	P1,P2,P3 defines a function P1: # function P2: Channel P3 : function MIN MAX PK_PK LOW HIGH AMPL P_OVERSH N_OVERSH FREQ PERIOD R_EDGE F_EDGE P_WIDHT N_WIDTH P_DUTTY_CYCLE N_DUTTY_CYCLE MEAN MEAN_CYC RMS RMS_CYC	MATHDEF 1,A1,MIN
MATH ?	read the values of each functions (only if the screen is in F(t))	

16.5.13. Replay (memory output)

HEADER	PARAMETERS	EXAMPLES
OUTBloc	P1,P2,P3 Defines the memory output block and output window. P1 = 1 to 128 block number P2 = 0 to 100 (% in real number from the beginning) P3 = 0 to 100 (% in real number to the end)	OUTBLOC 1,25.2,80 block 1 , beginning at 25.2 % and ending at 80 %
OUTBloc ?	Returns the command	
OUT:REC	P1,P2 Defines kind of plot on paper P1: FT or XY kind of plot P2 : Defines the reduction ratio in FT mode (from 1 to 10000 step 1,2,5) or the width of the grid in XY mode (100, 200 or 250)	OUT:REC XY,200 diagram XY, size 200x200 mm on paper OUT:REC FT,100 diagram F(t), 100 samples per mm.
OUT:REC ?	Returns the command	
PLOTRec	P1 Start ou stop the plotting of the screen P1=ON ou OFF	
PLOTRec ?	Returns the status of the plotting and the ratio of data written	
DEFPACQ	P1,P2 _P1 : number of the packets - P2: Lenght of the packet	OUTBLOC 2,0,100;DEFPACQ 0,50000;READPACQ ? Reading of block 2 : first paquet
READPACQ ?	Read the packer defined in with DEPPACQ (binary) * 4 bytes : lenght oh the packet * 4 bytes : Number of these packet * 4 bytes: Checksum of the packet * 4 bytes : lenght on the file (only for packet 0)	

16.5.14. Service request

See the explanations about the structure of status data.

HEADER	PARAMETERS	EXAMPLES																											
SRQ_ENABLE	P1 Allows to modify the alarm enable register P1 = register value <table border="0"> <tr> <td>bit</td> <td>decimale value</td> <td>use</td> </tr> <tr> <td>0</td> <td>1</td> <td>start of plot</td> </tr> <tr> <td>1</td> <td>2</td> <td>end of plot</td> </tr> <tr> <td>2</td> <td>4</td> <td>end of write</td> </tr> <tr> <td>3</td> <td>8</td> <td>no more paper</td> </tr> <tr> <td>4</td> <td>16</td> <td>door open</td> </tr> <tr> <td>5</td> <td>32</td> <td>start of memory record</td> </tr> <tr> <td>6</td> <td>64</td> <td>end of memory record</td> </tr> <tr> <td>7</td> <td>128</td> <td>trigger of memory record</td> </tr> </table>	bit	decimale value	use	0	1	start of plot	1	2	end of plot	2	4	end of write	3	8	no more paper	4	16	door open	5	32	start of memory record	6	64	end of memory record	7	128	trigger of memory record	SRQ_ENABLE 3 3 = 1 + 2 (bits 0 and 1) Start and End of plot events are authorized to be indicated in the status byte register (bit 0).
bit	decimale value	use																											
0	1	start of plot																											
1	2	end of plot																											
2	4	end of write																											
3	8	no more paper																											
4	16	door open																											
5	32	start of memory record																											
6	64	end of memory record																											
7	128	trigger of memory record																											
SRQ_ENABLE ?	Returns the value of the alarm enable register																												
SRQ_TYPE ?	Returns the value of the alarm status register. The register is cleared. Each bit of this value is identical to the previously defined bit in SRQ_ENABLE.	SRQ_TYPE ? the recorder returns : SRQ_TYPE 4 so "a write operation is completed"																											

16.6. Error messages

Error N°	Explanation
1	Unknown header
2	Unknown parameter
3	Prohibited parameter
4	Missing parameter
5	Incorrect parameter separator
6	Incorrect message separator
7	Too long word
8	Incorrect format of text parameter
9	Prohibited query
10	Numerical parameter out of limits
11	Text parameter out of limits
12	Obligatory query
13	Transmission buffer full
14	Not possible in this contexte
15	Checksum error

When a problem arises in the programming via the interface of the recorder, a **Debug** window is displayed on screen to help you identify your error:

Each error is associated with a line that shows:

- an error number
- the received message

When the window is full, the errors are displayed again from the 1st line on.
The last line is followed by a blank line.

17. TECHNICAL SPECIFICATIONS

17.1. Isolated inputs

17.1.1. General characteristics

Number of inputs per module: 6

Impedance:

Impedance > 25 M Ω for ranges \leq 1 V
 Impedance = 1 M Ω for any other range

Optional board 984402300 :

Impedance > 25 M Ω for ranges \leq 1 V
 Impedance = 10 M Ω for any other range

Maximum possible voltages:

Between a measure channel and the ground: + 500 V DC or 500 V AC 50 Hz
 Between the 2 terminals of a channel: +500 V DC or 500 V AC 50 Hz

Category of installation: overvoltage category: III 600V

Isolation: between the ground and the measure channel: >100 M Ω at 500 V DC.

Spurious common mode voltages: test according to EN 61143

Types of measures :

Voltage, current (by external shunt)
 Frequency
 Thermocouple probe J, K, T, S, B, N, E, C(W5)

17.1.2. Voltage recording

<i>Maximum range</i>	1000 V	(-500 V to +500 V)
<i>Minimum range</i>	1 mV	(-0.5 mV to +0.5 mV)
<i>Offset</i>	Adjustment of the centre by 1/5000 of the full scale or by 1/2-range	
<i>Maximum offset</i>	+ 5 range (except 1000V)	
<i>Accuracy</i>	\pm 0.1% of the full scale, \pm 10 μ V, \pm 0.1% of the zero offset	
<i>Offset drift</i>	100 ppm/ $^{\circ}$ C, \pm 1 μ V/ $^{\circ}$ C	
<i>Class C index</i>	see appendix	

17 – Technical specifications

17.1.3.RMS recording

RMS calculation by the software

<i>Sampling</i>	200 μ s
<i>Maximum frequency</i>	500 Hz
<i>Crest factor</i>	2.2 and 600 V max instant.
<i>Accuracy</i>	± 1 % (wave signal)
<i>Response time</i>	typical. 100 ms (40ms for 50Hz signal)
<i>Measurable max. voltage</i>	424 V AC

17.1.4.Temperature recording

TRANSDUCER	Operating field	RANGE
PT100	-200°C à 850 °C	20 °C à 1000 °C
COUPLE J	-210°C à 1200 °C	20 °C à 2000 °C
COUPLE K	-250°C à 1370 °C	20 °C à 2000 °C
COUPLE T	-200°C à 400 °C	20 °C à 500 °C
COUPLE S	-50°C à 1760 °C	50 °C à 2000 °C
COUPLE B	200°C à 1820 °C	50 °C à 2000 °C
COUPLE E	-250°C à 1000 °C	20 °C à 1000 °C
COUPLE N	-250°C à 1300 °C	20 °C à 1000 °C
COUPLE C	0°C à 2320 °C	50 °C à 2000 °C

The accuracy of the thermocouples is indicated in the appendix

Compensation of the cold junction of the thermocouples J,K,T,S,N,E,C(W5): ± 1.25 °C

17.1.5.Frequency record:

<i>Threshold :</i>	from -99V to 99 V step 0.1 V (using only for frequency <10Hz)
<i>Sensitivity</i>	100 mVrms min.
<i>Minimum duty factor</i>	10 %.
<i>Frequency</i>	from 0.1Hz to 100 kHz.
<i>Accuracy</i>	0.2 % of the full scale

17.1.6.Count Record

<i>Threshold :</i>	from -99V to 99 V step 0.1 V
<i>Accuracy :</i>	1% of threshold +100mV

Maximum count in a record memory : 65535

Maximun count in the numeric screen: 4E9

17.1.7.Sampling

<i>Resolution:</i>	14 bits
<i>Max. sampling period:</i>	
Memory mode:	1 μ s (i.e. 1 MHz)
Direct mode:	200 μ s (i.e. 5 kHz)
<i>Max. sampling duration:</i>	10 min

17.1.8. Bandwidth

Bandwidth at -3 dB:	
Range	Bandwidth
> 1 V	100 kHz
> 50 mV	50 kHz
20 mV	30 kHz
10 mV	30 kHz
5 mV	20 kHz

Optional board 984402300 :

Range	Bandwidth
>10V	>20 KHz
> 500 mV	>10 KHz
> 50 mV	>50 KHz
20 mV	>30 KHz
10 mV	>30 KHz
5 mV	>20 KHz

<i>Internal analogical filters:</i>	10 kHz ,1 kHz, 100 Hz, 10Hz
slope:	20 dB/decade

<i>Software filters:</i>	1 Hz, 0,1 Hz, 0,01 Hz, 0,001 Hz
--------------------------	---------------------------------

17.2. Multiplexed inputs

17.2.1. General characteristics

Number of inputs per module: 12

Inputs type differential non isolated

Impedance:

Impedance > 10 M Ω for ranges \leq 2 V

Impedance = 2 M Ω for any other range

Maximum possible voltages:

Between a measure channel and the ground: 48 V DC

Between the 2 terminals of a channel: 48 V DC

Maximal common mode voltages :

\pm 3 V for ranges \leq 2 V

\pm 50 V for any other range

Type of measurements:

Voltage, current (by external shunt)

Thermocouple J, K, T, S, B, N, E, C(W5)

PT100 2, 3 or 4 wires

17.2.2. Voltage recording

Maximum range 50 V (-25V to +25V)

Minimum range 1 mV

Offset Adjustment of the centre by software

Accuracy \pm 0.1% of the full scale, \pm 10 μ V, \pm 0.1% of the offset

Offset drift 100 ppm/ $^{\circ}$ C \pm 1 μ V/ $^{\circ}$ C

17.2.3. RMS recording

RMS calculation by software

Sampling 200 μ s

Maximum frequency 100 Hz

Crest factor 2.2 (max 30V)

Accuracy \pm 1 % (wave signal)

Response time typical. 100 ms(40ms for 50Hz signal)

17.2.4. Temperature recording

(For thermocouples see 17.1.4)

PT100 2, 3 or 4 wires

Maximum compensation resistor :

PT100 2 wires :	30 Ohms
PT100 3 wires :	100 Ohms

17.2.5. Sampling

Resolution: 16 bits

Max. sampling period: 200 μ s

Max. sampling duration: 10 min

17.2.6. Bandwidth

Bandwidth at -3 dB 1 kHz

Software filters: 100Hz, 10Hz, 1 Hz, 10s, 100s, 1000s

17.3. Measurement bridge inputs

17.3.1. General characteristics

Number of inputs per module 6

Measurement of tension, thermocouple and gauge (power supply to the bridge provided by the rack)

Isolated differential type inputs

Impedance:

Impedance = 2 M Ω for gauges < 1 Volt

Impedance = 1 M Ω for gauges \geq 1 Volt

Allowed maximum tensions:

Between a measurement input or the mass and the mechanical mass: 200V DC

Maximum tensions between the inputs, or between an input and the rack mass: \pm 50V

Isolation: between mechanical mass and measurement channel: >1000 M Ω for 500V

Measurement types:

Tension, intensity (through an external shunt), thermocouple, gauge

The accuracy values are specified for the 1Hz filter.

17.3.2. Tension recording

<i>Maximum rating</i>	50 V
<i>Minimum rating</i>	1 mV
<i>Offset</i>	Adjustment of the middle point by 1/5000 of the full scale or by half-ratings
<i>Maximum offset</i>	\pm 50V (zero offset by \pm 5 ratings without changing the rating)
<i>Accuracy</i>	\pm 0,1% of the full scale, \pm 10 μ V, \pm 0,1% of the offset
<i>Offset drift</i>	100ppm/ $^{\circ}$ C \pm 1 μ V/ $^{\circ}$ C
<i>Noise</i>	<20 μ V w/o filter

17.3.3. RMS recording

software-based RMS calculation

<i>Resolution</i>	200 μ s
<i>Maximum frequency</i>	500Hz
<i>Peak factor</i>	2.2
<i>Accuracy</i>	\pm 1% (sinusoidal signal)
<i>Time lag</i>	typically 100ms

17.3.4. Derived and integral recording

<i>Integration time</i>	from 200 μ s up to 1s (for every channels)
<i>Input rating</i>	adjustable from ± 0.5 mV up to ± 25 V
<i>Input filters</i>	(see chapter "pass band")

17.3.5. Gauge type recording

The selected unit is μ STR (micro strain). Gauges also show measurements in mV/V
The equivalence is: 2000 μ STR = 1mV/V

<i>Automatic zeroing</i>	$\pm 25,000\mu$ STR
<i>Supply tension of the bridge</i>	2V and 5V (symmetrical ± 1 V and ± 2.5 V)
<i>Gauge coefficient</i>	2 (adjustable between 1.8 and 2.2)
<i>Maximum rating</i>	50,000 μ STR
<i>Minimum rating</i>	1000 μ STR
<i>Offset</i>	Adjustment of the middle point by 1/5000 of the full scale or by half-ratings
<i>Maximum offset</i>	$\pm 50000\mu$ STR
<i>Accuracy</i>	$\pm 0.1\%$ of the full scale, $\pm 5\mu$ STR, $\pm 0.1\%$ of the offset
<i>Offset drift</i>	100ppm/ $^{\circ}$ C, $\pm 1\mu$ V/ $^{\circ}$ C

17.3.6. Temperature recording

(For thermocouples see 17.1.4)
PT100 and PT1000 2 or 4 wires.

17.3.7. Sampling

<i>Resolution</i>	16 bits
<i>Max sampling period</i>	
<i>Memory and file mode</i>	10 μ s (which means 100kHz)
<i>Direct mode</i>	200 μ s (which means 5kHz)

17.3.8. Bandwidth

<i>Bandwith @ -3 dB</i>	>18 kHz
<i>Low-pass analogical filter 60dB/decade</i>	1kHz, 100Hz, 10Hz
<i>Low-pass software filters</i>	1Hz, 0.1Hz, 0.01Hz, 0.001Hz

17.4. Supplementary inputs / outputs

17.4.1. Logical channels

<i>Number of channels</i>	16
<i>Input impedance</i>	4.7 k Ω
<i>Sampling period</i>	the same as the main inputs
<i>Maximum permitted voltage</i>	24 V

17 – Technical specifications

17.4.2. Alarm outputs

Alarm A dry contact (relay) free of any potential (24V/100 mA).

Alarms B and C TTL 5V outputs

These circuits are open when the power supply is off.

17.4.3. External power supply

Nominal voltage 12 V / mechanical grounding

Maximum current 0,2 A limited by a resettable fuse

17.5. Power Analysis

This information relies on the hypothesis, that the nominal input values are true.

17.5.1. Ranges and Specifications for Tension and Intensity

RMS tension:

- Range: between 1mV_{rms} to 400V_{rms}
- Accuracy: 0.5% of nominal tension

RMS intensity:

- Range: The intensity must always be calculated with reference to a tension: the input value must range within the given limits for tension. In most cases, the instrument you are using to measure the current will determine the measurement range.
- Accuracy: (0.5% of nominal intensity + error range of the measuring instrument)

Active power:

- Accuracy: Error on the current + Error on the tension

Example

Measurement of a 230V tension and a 10A current with a SP221 clamp (accuracy: 1%; 1A in input yields 100mV in output on the network analyser).

- *Tension:* 0.5 % accuracy
- *Current:* $0.5\%+1\%=1.5\%$ accuracy
- *Power:* The accuracy is $0.5+1.5=2\%$

Power supply tension and frequency of the appliance:

In the case where the recorder works in nominal functioning conditions (see chapter 10.7), the errors from the influence of the power supply tension and frequency have negligible effects within 10% distortion and $\pm 2\%$ frequency variation (case of a network supplied by a generating unit).

Magnetic fields:

The current sensors you use must absolutely comply with the valid standards and feature the CE mark. The influence on the recorder is negligible when it stands in a 100A/m 0-50Hz field. As far as possible, remove the sensors you use from any magnetic source.

17.5.2. Frequency

Range: from 45 up to 65Hz
Accuracy: 0,01 Hz
Sensitivity: 5% of the nominal tension

17.5.3. Power factor

Accuracy: output value \pm 0.05

17.5.4. Peak and peak factor

Peak: Accuracy: 0.5% of the nominal tension or current
Peak factor: Accuracy: 1% up to 5

17.5.5. Harmonic rates, calculated in power analysis

Range: THD: from 0% up to 600%
 FD: from 0% up to 100%
Accuracy: output value \pm 2.5%

Harmonics: from the order 2 up to the order 50
Range: from 0% up to 600%
Accuracy: output value \pm 1% up to the 30th harmonic order
 output value \pm 1.5% from the 31st up to the 50th harmonic order

17.6. Paper

<i>Paper width</i>	270 mm
<i>Plotting width</i>	256 mm
<i>Paper speed</i>	from 1 mm/h up to 200 mm/s or external speed
<i>Memory transcription</i>	max. 10 mm/s
<i>Paper feed</i>	100 mm/s
<i>Text mode</i>	1s period / line at 1 line/ hour
<i>XY mode</i>	100 x 100, 200 x 200, 250 x 250 mm.
<i>Resolution and accuracy:</i>	
along the X-axis:	8 dots / mm
along the Y-axis:	16 dots / mm up to 50 mm/s else 8 dots / mm
in XY mode:	8 dots / mm along the 2 axes
<i>Accuracy of the paper speed</i>	0.5 % (<200 mm/s)
<i>Accuracy in regard with the reticule</i>	0.01%

17 – Technical specifications

17.7. Display

<i>Screen</i>	12.1” TFT, colour, back-lighting
<i>Total resolution</i>	XGA 1024x768 dots
<i>Zone of display of the signals</i>	1000 x 600 dots

17.8. Memory acquisition

<i>Memory amount</i>	32 Msamples (can be divided until 128 blocks)
<i>Max sampling duration</i>	10 min
<i>Max. sampling frequency</i>	1 MHz
<i>Trigger positioning</i>	from -100% to +100%

17.9. File acquisition

<i>Size of the internal hard disk</i>	40 Go min
<i>Maximum transfer rate:</i>	
digital values	1.2 Msample/s
ascii values	1 Ksample/s

The real transfer rate depends on the number of channels to acquire and on the current mode.

17.10. Communication interface

Communication (remote control) only via Ethernet.

<i>Speed</i>	10/100 base-T
<i>Connector</i>	RJ45
<i>Protocol</i>	TCP/IP
<i>Connexion port</i>	23

17.11. Miscellaneous

17.11.1. USB Connectors

For keyboard, mouse , memory keys or printer.

<i>Standard</i>	USB 2 or USB1
<i>Type</i>	4 female connectors type A

17.11.2. Screen connector

<i>Standard</i>	XGA 1024x768 dots
<i>Type</i>	DB15, 15 dots high density

17.12. Environmental conditions for chart recorder

17.12.1. Weather conditions

<i>Functioning temperature</i>	from 0°C to 40°C
<i>Max. relative humidity</i>	80 % non-condensing
<i>Storage temperature</i>	from -20°C to 60°C

17.12.2. Mains power supply

<i>Voltages permitted</i>	115 V _{AC} (85 V _{AC} to 132 V _{AC}) or 230 V _{AC} (170 V _{AC} to 264 V _{AC}) (automatic selection)
<i>Frequency</i>	47 to 63 Hz
<i>Just-operated current</i>	< 38 A in peak
<i>Consumption</i>	max. 230W (60W without plotting)

Internal fuse not accessible by the user (without dismantling)

17.12.3. Dimensions, weight

<i>Height</i>	195 mm
<i>Width</i>	440 mm
<i>Depth</i>	370 mm
<i>Weight</i>	11 kg

17.13. Environmental conditions for paperless recorders

17.13.1. Weather conditions

<i>Functioning temperature</i>	from 0°C to 40°C
<i>Max. relative humidity</i>	80 % non-condensing
<i>Storage temperature</i>	from -20°C to 60°C

17.13.2. Mains power supply

<i>Voltages permitted</i>	115 V _{AC} or 230 V _{AC} (85 V _{AC} to 264 V _{AC}) (automatic selection)
<i>Frequency</i>	47 to 63 Hz
<i>Just-operated current</i>	< 40 A in peak
<i>Consumption</i>	47W max.

Internal fuse not accessible by the user : contact the after-sales service

17.13.3. Dimensions, weight

<i>Height</i>	384 mm
<i>Width</i>	445 mm
<i>Depth</i>	195 mm
<i>Weight</i> Paperless 6-36 channels	7.5 kg
<i>Weight</i> paperless 6 channels	5.0 kg

17 – Technical specifications

17.14. Electromagnetic compatibility , Security

17.14.1. Electromagnetic compatibility

Designation	Accordance test	Specifications	Limits	Criteria
Radiated Emissivity *	NF EN 55022	30 MHz to 230 MHz 230 MHz to 1 GHz	Measure distance 10 meters 40 dB μ V/m 47 dB μ V/m	Class A
Conducted Emissivity (lines, power supply)	NF EN 55022	0,15 MHz to 0,5 MHz 0,5 MHz to 5 MHz 5 MHz to 30 MHz	66 to 56 dB μ V QP 56 dB μ V QP 60 dB μ V QP (mean value = QP - 10dB)	Class B
Harmonic Distortion	CEI 61000-3-2	0 to 2 kHz	Picture 1 of the standard	Class A
Variation of tensions and flickers	CEI 61000-3-3		chap 5 of the standard	-
Enveloppe immunity	CEI 61000-4-2	Air Contact discharges	N = +/- 4 kVolts N = +/- 8 kVolts	Criteria B
	CEI 61000-4-3	80MHz to 1 GHz 1,4 GHz to 2 GHz AM 80% 1000Hz	10 V/m without mod.	Criteria A
	CEI 61000-4-8	50 Hz	30 A/m	Criteria B
Access immunity	CEI 61000-4-4	5-50 ns / 5 kHz	Line energy +/- 2 kV Line Ethernet +/- 1 kV Line measure input +/- 1 kV Line earth +/- 1 kV	Criteria B
	CEI 61000-4-5	1,2 / 50 μ s (8/20)	line / line +/- 1 kV line / earth +/- 2 kV	Criteria B
	CEI 61000-4-6	150 kHz to 80 MHz AM 80% 1000 Hz	Line energy Line Ethernet Line input measure	3V without mod. Criteria A
	CEI 61000-4-11	Reduction 100%	0,5 cycle with each polarity	Criteria B

* Test conditions : the test is to be carried out with EUT (equipment under test) protective earth terminal of cabinet connected with the reference ground plane (see label 9, chapter 2.2); see also chapter 3.4.5 Connection of the grounding

Assessment criteria for the functioning that were applied for the test:

Criteria A : Normal behaviour within the limits of the specifications

Criteria B : Temporary decrease or self-recovered loss of function

Criteria C : Temporary decrease or loss of function or behaviour that requires the intervention of the user or a reset of the system

17.14.2. Security, Isolation Class, Installation Category

Class 1 product

Security conform with EN61010-1
Pollution degree 2

Installation category (overvoltage category)

Mains input category II
Measurement input category III 600 V, overvoltage 6000 V



Particular precautions are necessary to preserve the conformity of the product, particularly the use of shielded cables.

17.15. Miscellaneous

17.15.1. Internal saving battery

Saving the configurations and the clock

Battery lithium 3.0V button battery
Preservation of the data min. 5 years

The user cannot change it: contact the after-sale service.

17 – Technical specifications

17.16. Accessory items

17.16.1. Items furnished with the appliance

User's manual

CD with software

Common accessory pack for chart and paperless recorders:

- 1 mains cable 241510312
- 1 male 25-pin connector 214200250
- 1 connector cap 214299014
- 1 mouse 984406000

Specific Accessory for chart recorder:

- 1 roll of paper: 30 m 837500504

Accessory with 6 isolated channels module:

- 1 black single-pin plug per channel 215508020
- 1 red single-pin plug per channel 215508021

Accessory with 12 non-isolated channels module:

- 1 screw terminal 5-pins per channel 315018045

Accessory with 6 isolated bridge module:

- 1 screw terminal per channel 315018048

17.16.2. Optional accessory items

Universal 6-channel inputs	see the sales service
Universal 6-channel inputs with high impedance	984402300
Multiplexed 12-channel inputs	see the sales service
Transport case	984167000
19" rack	984208000
0.01 Ω 1% 3A plug-in shunt	910007100
0.1 Ω 1% 1A plug-in shunt	910007200
1 Ω 0.1% 0.5A plug-in shunt	989006000
10 Ω 0.1% 0.15A plug-in shunt	912008000
50 Ω 0.1% 0.05A plug-in shunt	989007000
0.01 Ω 0.5% 30A external (plugs)	207030301
0.001 Ω 0.5% 50A external (clips)	207030500
ordinary Ethernet cable	910007300
basic FLEXPPO software	910008100
complete FLEXPPO software	910008200

17.16.3. Expandable items (optional)

30m roll of paper (standard)	837500504
Long life 30m roll of paper	837500510
High sensitivity 30m roll of paper	837500521
Pre-cut A4 roll of paper	837500522
Kit of supplementary items for isolated 6 channels module	984010000
Kit of supplementary items for non-isolated 12 channels module	984402100

18. APPENDIX

18.1. Information about the ranges of the inputs

Definition:

The range is the difference between the maxi and mini measurement that we can display on trace on the paper.

Origin is the middle of the paper or the middle of the display

18.1.1. Voltage isolated inputs

These inputs include an analog offset system that allow ± 5 range offset..

So we can modify the origin without changing the resolution for ± 5 ranges

You can enter any value for the range and any value for the origin, then the software find the true offset and range following the table below

RANGE	Origin Offset	Mini Measurable	Maxi measurable
1mV	+5mV	-5.5mV	+5.5mV
2mV	+10mV	-11mV	+11mV
5mV	+25mV	-27.5mV	+27.5mV
10mV	+50mV	-55mV	+55mV
20mV	+100mV	-110mV	+110mV
50mV	+250mV	-275mV	+275mV
100mV	+500mV	-550mV	+550mV
200mV	+1V	-1.1V	+1.1V
500mV	+2.5V	-2.75V	+2.75V
1V	+5V	-5.5V	+5.5V
2V	+10V	-11V	+11V
5V	+25V	-27.5V	+27.5V
10V	+50V	-55V	+55V
20V	+100V	-110V	+110V
50V	+250V	-250V	+250V
100V	+450V	-500V	+500V
200V	+400V	-500V	+500V
500V	+250V	-500V	+500V
1000V	0	-500V	+500V

Fig 1

18.1.2. Multiplexed voltage input

These inputs doesn't include analog offset, it is only software offset.

The software takes the analog measurement range including the programmed measurement range

RANGE	MEASUREMENT RANGE
1mV	-500μV to +500μV
2mV	-1mV to +1mV
5mV	-2.5mV to +2.5mV
10mV	-5mV to +5mV
20mV	-10mV to +10mV
50mV	-25mV to +25mV
100mV	-50mV to +50mV
200mV	-100mV to +100mV
500mV	-250mV to +250mV
1V	-500mV to +500mV
2V	-1V to +1V
5V	-2.5V to +2.5V
10V	-5V to +5V
20V	-10V to +10V
50V	-25V to + 25V

Fig 2

18.1.3. Thermocouple input

Thermocouple measurement is same as voltage measurement.

For a given temperature measurement range the software take a voltage measurement range as follow:

- *Take « T » the maximum temperature absolute value in °C to be measured
- *Add 40°C to “T”. This take into account the maximum cold junction temperature
- *Find in the thermocouple table the corresponding voltage value “U”
- *Apply the analog voltage range including the “U”
- *For isolated input the analog offset aren't used

Example :

We want to measure from -50°C up to + 50°C with a J thermocouple

- absolute maximum value T = 50°C
- add 40°C T + 40 = 90°C
- Voltage U corresponding in thermocouple table J U = 4.726mV
- Range applied : 10mV (from -5mV to +5mV)

18.2. Accuracy of thermocouple measurements

The accuracies below are given as maximum values : typical values are 2 or 3 times lower.

For thermocouple measurement the accuracy is the sum of several sources of inaccuracy:

Pl : accuracy of thermocouple interpolation (we haven't all table point)

Ps : cold junction temperature accuracy

Pm : accuracy of equivalent voltage measurement

The total accuracy is then : $P_t = P_l + P_s + P_m$

For the recorder

$P_l = \pm 0.25 \text{ }^\circ\text{C}$ for all thermocouple

$P_s = \pm 1.25 \text{ }^\circ\text{C}$ for all thermocouple

$P_m = (0.1\% \text{ of voltage range} + 10\mu\text{V})$ divided by the thermocouple slope en $\mu\text{V}/^\circ\text{C}$

Measurement accuracy : P_m

The measurement accuracy depends on the voltage range (see previous §) and on the thermocouple slope. We take the slope at 0°C , for more accurate calculation we should take the slope at the temperature we are verifying, but it is a second order calculation .

Example of accuracy calculation

We want to measure from -50°C up to $+50^\circ\text{C}$ with a J thermocouple with cold junction compensation.

→Used range	10mV (see previous example)
→Voltage measurement accuracy	$0.1\% * 10\text{mV} + 10\mu\text{V} = 20\mu\text{V}$
→Thermocouple J slope	$50 \mu\text{V}/^\circ\text{C}$
→Accuracy P_m	$P_m = 20/50 = 0.4^\circ\text{C}$
→Total accuracy = $P_l + P_s + P_m$	$P_t = 0.25 + 1.25 + 0.4 = 1.9^\circ\text{C}$

18.3. Accuracy of the PT100 measurement

The accuracies below are given as maximum values : typical values are 2 or 3 times lower.

A PT100 measurement is a voltage measurement.

A current of 1mA pass through the PT100 probe and we measure 100mV for 100Ohm (0°C) in 4 wires mode..

For PT100 measurement the accuracy is the sum of several sources of inaccuracy:

Pl : accuracy of PT100 interpolation (we haven't all table point)

Pz : accuracy of the zero °C (100mV offset)

Pm : accuracy of equivalent voltage measurement around the zero

The total accuracy is then : $Pt = Pl + Pz + Pm$

For the recorder

$Pl = \pm 0.1 \text{ } ^\circ\text{C}$

$Pz = \pm 0.25 \text{ } ^\circ\text{C}$

$Pm =$ see following table (0.1% of the range + 10 μV) divided by the slope (in $\mu\text{V}/^\circ\text{C}$)

Voltage Range	+/-5mV	+/-10mV	+/-25mV	+/-50mV	+/-100mV	+/-250mV	+/-500mV
Mini Measurement	-12°C	-25°C	-63°C	-125°C	-200°C	-200°C	-200°C
Max measurement	+12°C	+25°C	+64°C	+130°C	+266°C	+715°C	+850°C
Accuracy Pm in μV	20 μV	30 μV	35 μV	60 μV	110 μV	260 μV	510 μV
*Accuracy Pm in °C	0.06°C	0.09°C	0.1°C	0.17°C	0.32°C	0.76°C	1.5°C

Fig 3

*The accuracy Pm is given in °C for the slope at 0°C : 342 $\mu\text{V}/^\circ\text{C}$,

The accuracy depends on the measured accuracy , for more detail use the table below (slope as a function of the temperature)

The PT100 measurement range is limited from -200°C to +850°C

Slope as function of the temperature :

Temperature(°C)	-200	-100	0	200	400	600
Slope ($\mu\text{V}/^\circ\text{C}$) (or mOhm/°C)	378	354	342	321	301	281

Fig 4

Example of accuracy calculation for PT100

We make measurements with a PT100 probe between -100 and $+100^{\circ}\text{C}$

→ voltage range using table Fig 3 $\pm 50\text{mV}$
 → Pm using table Fig 3 0.17°C
 → total accuracy Pt $P_t = P_l + P_z + P_m = 0.1 + 0.25 + 0.17 = 0.52$

18.4. Accuracy of instantaneous measurement as a function of filter

The instantaneous accuracy is given with a 10Hz filter: $\pm 0.1\%$ of full scale $\pm 10\mu\text{V}$ $\pm 0.1\%$ of the offset.

For higher frequency filter and lower span (high gain), the noise becomes more important: it is advised to add a spec for the noise. It is not possible for example to have an accuracy of 0.1% for the span 1mV without filter.

The grid below gives typical peak to peak noise for several span and filter.

The measurements are made with a continuous voltage apply between « - » plug connected to the ground earth and « + » plug (to have no common mode).

Span	1mV	2mV	5mV	10mV	20mV	50mV	100mV	200mV	>200mV
filter	1kHz	1kHz	1kHz	10kHz	10kHz	10kHz	No	No	No
typical noise	3%	1.5%	0.7%	1%	0.6%	0.2%	0.6%	0.5%	0.3%

The noise is proportional to the square root of the bandwidth. To have the noise with other filters you must take the square root of the bandwidth ratio.

Example:

Noise for 10mV span with a 10Hz filter ?

Noise = 1% with 10kHz filter

Ratio = $\text{SquareRoot}(10000/10) = 32$

The noise is divided by 32

Noise = 0.03% with a 10Hz filter

18.5.

18.6. Note on the measurement units in measurement bridge

The base unit selected for the measurements on measurement bridge is μS (micro Strain), applied on a complete bridge equipped with only one strain-sensitive resistance.

If the bridge is equipped with 2 or 4 strain-sensitive resistances, or if the characteristic value of the bridge is displayed in mV/V , you can easily change of unit by using the unit change function.

Fundamentally, the measurement is always a tension value measurement.

18.6.1. Conversion rules

Complete bridge with 1 active resistance: strain = default measurement (μS)

Complete bridge with 2 active resistances: strain = default measurement divided by 2 (μS)

Complete bridge with 4 active resistances: strain = default measurement divided by 4 (μS)

mV/V display: use the conversion rule $1\text{mV/V} \Leftrightarrow 2000\mu\text{S}$

Volt display (if excitation = 2V and $G=2$): $1\mu\text{V} \Leftrightarrow 1\mu\text{S}$

18.6.2. Calculation details

- Case of a complete bridge with only one variable resistance (default case)

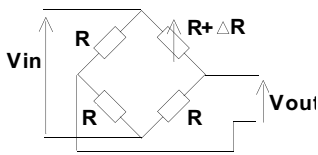

V_{in} : excitation tension of the bridge

G: gauge factor

R: resistance of the measurement bridge

V_{out} : measured tension between the middle points of the bridge

$S = \Delta L/L$: lengthening of the gauge or strain

For a bridge with 4 identical resistances, where one resistance undergoes a ΔR resistance variation, you can demonstrate:

$$V_{out} \approx (V_{in} / 4) * (\Delta R/R)$$

with $\Delta R/R = G * \Delta L/L$

$$V_{out} = (V_{in} / 4) * G * \Delta L/L \quad (1)$$

$$V_{out} = (V_{in} / 4) * G * S \quad (1)$$

Considering the general case $G = 2$, you get:

for $V_{in} = 2V$	$\rightarrow V_{out} = S$	\rightarrow	$1\mu V \Leftrightarrow 1 \mu S$
for $V_{in} = 5V$	$\rightarrow V_{out} = 2.5 * S$	\rightarrow	$2,5\mu V \Leftrightarrow 1 \mu S$

- Case of a complete bridge with 2 variable resistances

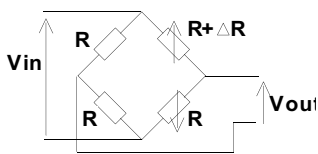

$$V_{out} = (V_{in} / 2) * G * S$$

- Case of a complete bridge with 4 variable resistances

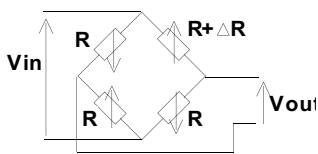

$$V_{out} = (V_{in}) * G * S$$

18.6.3.Characteristic value for a bridge in mV/V:

For some bridges, the characteristic value is displayed in mV/V

The equation (1) is equivalent to:

$$V_{out}/V_{in} = G * S / 4$$

For $G = 2$, you get $V_{out}/V_{in} = S/2$

hence **1mV/V is equivalent to 2000 μ S**

18.6.4.Example of a change of unit:

A set of measurement bridge displays: 0.89mV/V for 600g

Conversion into μ S ($G=2$) $\rightarrow 0.89*2000 \rightarrow 1780\mu$ S for 600g

Using a change of unit with the following parameters:

Unit: gram

X1=0

Y1=0

X2=1780 μ S

Y2=600g

The measurements are now displayed in grams.

DECLARATION OF CE CONFORMITY

according to EEC directives and NF EN 45014 norm

DECLARATION DE CONFORMITE CE

suivant directives CEE et norme NF EN 45014



SEFRAM INSTRUMENTS & SYSTEMES
32, rue Edouard MARTEL
42009 SAINT-ETIENNE Cedex 2 (FRANCE)

Declares, that the below mentioned product complies with :
Déclare que le produit désigné ci-après est conforme à :

The European low voltage directive 2006/95/EEC :
La directive Européenne basse tension 2006/95/CE

NF EN 61010-031 Safety requirements for electrical equipment for measurement, control and laboratory use. Règles de sécurité pour les appareils électriques de mesurage, de régulation et de laboratoire.

The European EMC directive 2004/108/EEC :

Emission standard EN 50081-1.

Immunity standard EN 50082-1.

La directive Européenne CEM 2004/108/CE :

En émission selon NF EN 50081-1.

En immunité selon NF EN 50082-1.

Installation category *Catégorie d'installation :* **Réseau 300 V cat II**
Mesure 600 V cat III

Pollution degree *Degré de pollution :* **2**

Product name *Désignation :* **Recorder / Enregistreur**

Model Type : **8440 – DAS1400 – DAS 600**

Compliance was demonstrated in listed laboratory and record in test report number
La conformité à été démontrée dans un laboratoire reconnu et enregistrée dans le rapport numéro **RC 8440**

SAINT-ETIENNE the :
June ,24th 2006

Name/Position :
TAGLIARINO / Quality Manager