

DINALOG A 144 x 36 MF

A1400 - MF Light-Strip Indicator

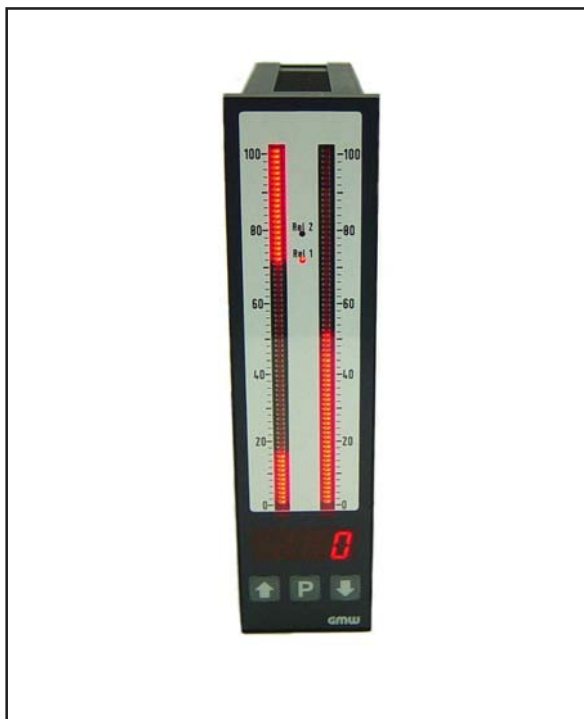

	Contents	Page
1.	Applications	4
2.	Installation	4
2.1	Dimensional Drawing	5
3.	Terminal Assignments	6
3.1	Power Supply	6
3.2	Measurement Input	6
3.3	Output	7
3.4	External Control Inputs	10
4.	Operation	11
4.1	Display programmed limit values	12
4.2	Display Test	12
4.3	Measuring Range Selection	13
5.	Basic Device Settings	14
6.	Programming	15
6.1	Adjusting Display Brightness	18
6.2	Light-Strip Adjustment	18
6.3	Lower Scale Limit	18
6.4	Upper Scale Limit	18
6.5	Scale Starting Point	19
6.6	Measuring Range Matching for 0...20 mA, 4...20 mA and ± 20 mA	19
6.7	Measuring Range Matching with HCA (hardware calibration)	20
6.8	Measuring Range Matching with PCA (software calibration)	21
6.9	Setting the Decimal Point	23
6.10	Mean Value Generation and Display	23
6.11	Limit Value Function	23
6.12	Relay Switching Mode	24
6.13	Relay Switching Function	24
6.14	Setting Relay Switching Hysteresis	25
7.	Setting the Limit Values	25
7.1	Locking the Selected Limit Values	26
7.2	Switching the Digital Display On and Off	26

	Contens	Page
8.	Technical Data	27

Notes and Warnings

This device has been shipped from the factory in flawless technical safety condition. In order to maintain this condition and to assure hazard-free operation, all notes and warnings which appear in the operating instructions must be observed by the user.

If, due to damage, it may be assumed that hazard-free operation of the device is no longer possible, it must be removed from service. This applies in any event if the device demonstrates visible damage.

Before placing the device into service, it must be assured that the measuring instrument has been configured correctly for the desired application (correct supply voltage, inputs and outputs). Specifications and any included options appear on the device's serial plate.

Voltage conducting parts may be exposed if covers are opened, or if components are removed from the device.

Balancing, maintenance and repair of live, open devices may only be carried out by suitably trained personnel, who are aware of the dangers involved.

1. Applications

The programmable light-strip indicator is a precision panel meter with adjustable display range. The display range can be adapted for the 4 ... 20 mA and 0 ... 20 mA measuring ranges after installation without the use of a calibrator. The measuring instrument is thus suitable for applications which require frequent on-site display range adjustments.

The measuring instrument can be optionally equipped with up to 4 limit values (2 or 4). Limit value violations are indicated optically with LEDs located within the scale. A relay is assigned to each limit value as well.

The measurement input can be configured by jumpering the measuring module for the following measuring tasks:

- *Direct current from ± 200 A to ± 200 mA*
- *Direct current 0 ... 20 mA or 4 ... 20 mA*

- *Direct voltage from ± 2 V to ± 300 V*
- *Direct voltage 0 ... 60 mV ... 300 mV,
0 ... 2 V ... 300 V*

2. Installation

Insert the measuring instrument into the control panel cutout from the front without the mounting tabs. Then insert the mounting tabs from the rear into the slots at the device side panels and tighten them against the control panel.



Attention!

If several devices are installed at maximum component density it must be assured that the maximum allowable operating temperature of 50 °C is not exceeded despite self-heating.

2.1 Dimensional Drawing

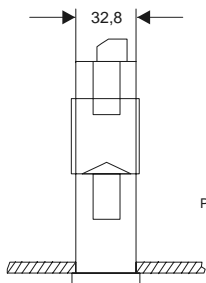
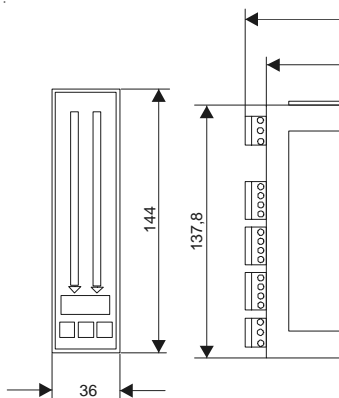

Panel Cutout 138 (+1) x 33 (+0.6)

All dimensions in mm

3. Terminal Assignments

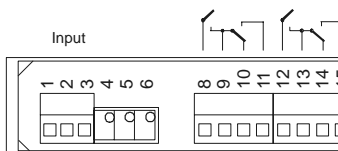

3.1 Power Supply



See specifications on the serial plate regarding power supply and connected load.

3.2 Measurement Input

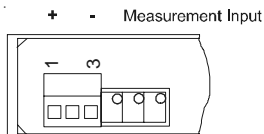

U/I - DC

3.3 Output

Device Type	Relay Type	Relay Terminal Assignments	
Single-contacting instrument (MECO)	see serial plate	Relay 1	Terminal 9, 10, 11 = changeover for 1. limit value
		Relay 2	Terminal 13, 14, 15 = changeover for 2. limit value
		Relay 3	Terminal 8, 9 = NO for 3. limit value
		Relay 4	Terminal 12, 13 = NO for 4. limit value

The contacting instrument is equipped with two limit values, two relays with changeover contacts are included (relay 1 and relay 2).

Each relay is assigned to one limit value. All relay contacts are electrically isolated from each another.

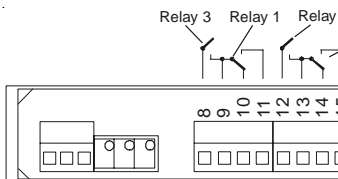

Indication of Limit Value Violations

Two LEDs are included at the scale for the indication of limit value violations for devices with two limit values. The switching status of relay 1 is indicated at LED Rel 1, and the switching status of relay 2 is indicated at LED Rel 2.

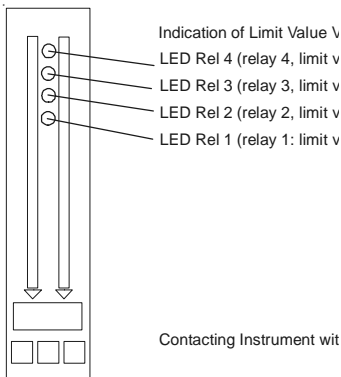

Switching Performance and Switching Status of Relays and Indicator LEDs

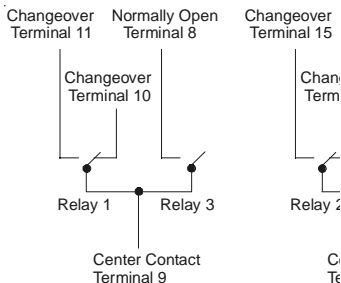

Working Current Model (nOP)

Limit Value Switch. Point	Meas. Value (MV) > < Limit Value (LV)	Changeover / NO Contact Terminal 11 or 15	Changeover / NO Contact Terminal 10 or 14	NO Contact Terminal 8 or 12	LED indication dep. upon selected limit value
Lo1 ... 4	MV > LV	open	closed	open	not illuminated
	MV < LV	closed	open	closed	illuminated
Hi1 ... 4	MV > LV	closed	open	closed	illuminated
	MV < LV	open	closed	open	not illuminated

Closed-Circuit Current Model (nCL)					
Limit Value Switch. Point	Meas. Value (MV) > < Limit Value (LV)	Changeover / NO Contact Terminal 11 or 15	Changeover / NO Contact Terminal 10 or 14	NO Contact Terminal 8 or 12	LED indication dep. upon selected limit value
Lo1 ... 4	MV > LV	closed	open	closed	not illuminated
	MV < LV	open	closed	open	illuminated
Hi1 ... 4	MV > LV	open	closed	open	illuminated
	MV < LV	closed	open	closed	not illuminated

3.4 External Control Inputs



Attention!

Terminals 17, 18, 19 and 20 are electrically connected to the measurement input. Insulation at external switching elements must be grounded appropriately for prevailing measurement input potential.

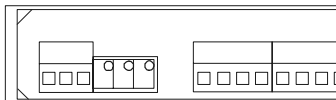

Reset and Device Test

The entire display can be cleared by establishing a connection between terminals 17 and 20.

Attention:

This connection causes resetting of the microprocessor. A segment test is performed for approximately 3 seconds after this connection has been interrupted. The device then resumes normal operation. Previous programming remains intact.

Freezing the Display Value (hold function)

The currently displayed value can be frozen during normal operation by establishing a connection between terminals 18 and 20. This does not influence the measuring cycle.

Disable Programming (lock function)

Configured parameters can be protected against change by establishing a connection between terminals 19 and 20. See chapter 7.1, page 25, for exceptions regarding limit value configuration.

4. Operation

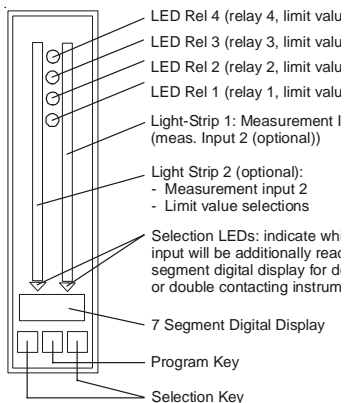

4.1 Display programmed limit values

By pressing the key \uparrow the limit value 1 is displayed (either as **Lo1** or as **Hi1** - according to the programmed switching function).

By pressing the key **P** the instrument goes back to the normal status. **3 (Lo3 or Hi3)** is displayed.

The same procedure for limit value 2 by pressing the key \downarrow .

4.2. Display Test

If the \uparrow , P and \downarrow keys are simultaneously pressed and held for approximately 1 second, the display is switched to the test mode. Alternately, Pro or the operating software revision level appears at the 7 segment display.

The display test is started by pressing the P key. The odd numbered segments (1, 3 ... 71) at the light-strips and the horizontal segments at the 7 segment display are activated and light up for portrait for-mat devices.

If the P key is pressed again, the even numbered segments (2, 4 ... 70) at the light-strips and the vertical segments at the 7 segment display are activated and light up for portrait format devices.

After pressing the P key a third time, all of the segments at the entire display are activated and light up.

The device can be returned to the normal display mode by once again pressing the P key.

4.3 Measuring Range Selection

The measuring range selection takes place by means of Jumper on the measuring range plate. In addition the equipment must be opened.

The snap-in tabs at the housing rear panel must first be carefully released by lifting the housing shell, after which the housing rear panel can be removed along with the complete PCB.

Attention:

This work may only be performed by trained personnel who are aware for the dangers involved. Electrostatically sensitive devices are included in these instruments. The usual protective measures must be observed in order to prevent electrostatic charging of such components. The guarantee is rendered null and void if the instrument is destroyed due to incorrectly implemented changes.

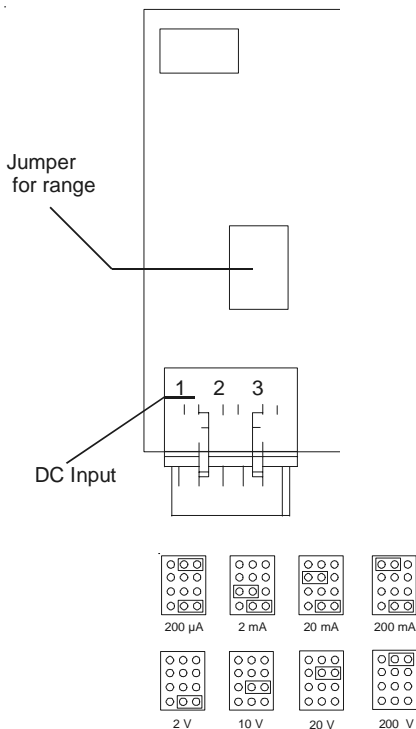

The indicator values for the zero point and/or the final value are stopped by the measuring range adjustment (see point 6.6) or by hardware- and/or software calibration (see point 6.7 and/or 6.8).

5. Basic Device Settings

Parameter	Function	Setting Range
bri	Display brightness (LEDs and light-strip)	0 ... 7 [5 ¹⁾]
4 ... 20	Measuring range matching	
ASt	Display range lower limit (start)	-999 ... 999
AEn	Display range upper limit (end)	-999 ... 999
0 ... 20	Measuring range matching	
ASt	Display range lower limit (start)	-999 ... 999
AEn	Display range upper limit (end)	-999 ... 999
± 20	Measuring range matching	
ASt	Display range lower limit (start)	-999 ... 999
AEn	Display range upper limit (end)	-999 ... 999
Pt	Measuring range matching ⁴⁾	
°C / °F	Display in degrees Celsius or ⁴⁾ Fahrenheit	
2,4L / 3L	2 / 4-wire connector or 3-wire connection ⁴⁾	
rES	Measuring range matching ⁴⁾	
200 / 2k / 20k	Resistance range ⁴⁾	200 Ω / 2 kΩ / 20 kΩ
2,4 L / 3L	2 / 4-wire connector or 3-wire connection ⁴⁾	
the	Measuring range matching ⁴⁾	
J / K / R / S	Thermocouple type selection ⁴⁾	
°C / °F	Display in degrees Celsius or Fahrenheit	
HCA	Hardware calibration	
ZEr	Display range lower limit	-999 ... 999
SPA	Display range upper limit	-999 ... 999
PCA	Software calibration	
OFS	Offset adjustment	-999 ... 999
SCA	Measurement value scaling factor	-9.99 ... 9.99
dP / .dP / dP.	Decimal point	

Parameter	Funktion	Einstellbereich
FIL	Mean value generationen based upon 0 to max. 32 measurement values	0; 2; 4; 8; 16; 32 ²⁾
SSt	Lower light-strip scale limit (start), channel 1 or 2, witch reference to the digital display	-999 ... 999
SEn	Lower light-strip scale limit (end), channel 1 or 2, witch reference to the digital display	-999 ... 999
SOr	Light-strip minimum scale value (origin) with reference to the digital display	SSt ≤ SOr ≤ SEn
nCL / nOP ³⁾	Switching performance: closed-circuit current (normally closed)/(working current (normally open), for all relays	
L-L ³⁾	Switching function for relais 1 and 2	L - L L - H H - H H - L
Lo1 / Hi1 ³⁾	Switching point for limit value 1	-999 ... 999
Lo2 / Hi2 ³⁾	Switching point for limit value 2	-999 ... 999
L-L ³⁾	Switching function for relays 3 and 4	L - L L - H H - H H - L
Lo3 / Hi3 ³⁾	Switching point for limit value 3	-999 ... 999
Lo4 / Hi4 ³⁾	Switching point for limit value 1	-999 ... 999
HYS ³⁾	Hysteresis	0 ... 100 [0 ¹⁾]
Loc ³⁾	Lock limit value	Loc, FrE [FrE ¹⁾]
diS / On	Switch digital displays on or off	diS / On diS / OFF

1) Factory default setting

2) A setting of either 8, 16 or 32 must be used for Pt100 sensors and thermocouples.

3) Only for devices with limit value read-out

4) At A1400-MF does not activate

6. Programming

The following parameters can be configured in the indicated order:

- LED and light-strip brightness
- Measuring range matching
- Decimal point
- Sampling rate for mean value generation
- Scale ranges with light-strip minimum value
- Switch digital display on or off

The following additional parameters can be configured for devices with limit values:

- Relay switching mode
- Relay switching function
- Switching point values
- Relay hysteresis
- Lock limit values

Enabling Programming

The lock function must be released in order to enable programming, i.e. contact between terminals 19 and 20 must be broken. If programming has not been enabled, **Loc** is displayed when the programming menu is opened. If this is the case, previously programmed values can be queried but not changed.

See chapter 7.1, page 25, for exceptions to this rule.

Programming

The measuring instruments are programmed at the factory in accordance with customer specific requirements. If programming has been enabled, the basic device settings can be changed with the three keys at the front panel.

For devices with double display (2 measurement inputs), either the \uparrow or the \downarrow key must be activated before entering the programming menu in order to select the channel (CH1 or CH2) to be programmed. The corresponding channel selection LED lights up.

The P and \uparrow keys must be pressed simultaneously (first P and then \uparrow) in order to enter the programming menu. The parameter designation and the corresponding value blink alternately in order to provide the user with orientation. Values can be changed with the \uparrow and \downarrow keys. The longer these keys are held depressed, the faster the value changes. The selected value is not saved to memory until the next parameter is queried by pressing the P key.

Various possibilities are provided for adapting the display to the input quantity. The various range matching options for 0 ... / 4 ... 20 mA, \pm 20 mA, Pt100, Res and thermocouples are dependent upon the utilized measuring module and may only be selected if the device has been equipped with the corresponding measuring module (see designation on the serial plate). A measuring range type and the corresponding parameter settings can then be selected. For the type MF only the various range matching options for mA are relevant. Incorrect selection of measuring ranges results in malfunction!

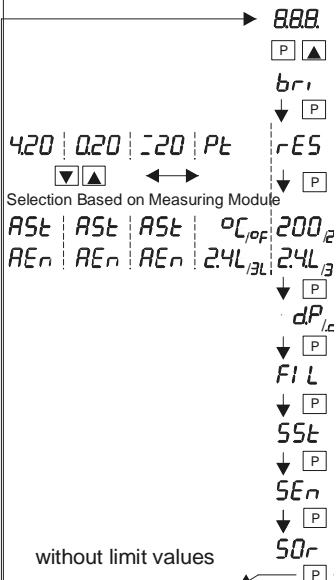

6.1 Adjusting Display Brightness

Display brightness can be adjusted with the **bri** parameter. A setting can be selected within a range of 0 to 7. Brightness is adjusted to 5 at the factory.

6.2 Light-Strip Adjustment

The light-strip indicates measured values at the analog scale. The display range can be set anywhere within the measuring range. The light-strip is preset at the factory. If the default settings need to be changed, this is accomplished in the program menu starting with the **SSt** parameter (see „Programming Overview for Basic Device Settings“ on page 16).

6.3 Lower Scale Limit

SSt and a **numeric value** blink alternately at the 7 segment display. This number corresponds to the digital display value which represents the lower scale limit at the light-strip (minimum scale value is at the bottom for portrait format devices, and at the left for land-scape format devices). This value can be changed with the \uparrow and \downarrow keys. The selected value is saved to memory by pressing the P key, and the upper scale limit then appears at the display.

6.4 Upper Scale Limit

SEn and a **numeric value** blink alternately at the 7 segment display. This number corresponds to the digital display value which represents the upper scale limit at the light-strip (maximum scale value is at the top for portrait format devices, and at the right for landscape format devices). This value can be changed with the \uparrow and \downarrow keys. The selected value is saved to memory by pressing the P key, and the minimum scale value then appears at the display.

6.5 Minimum Scale Value

SOr and a **numeric value** blink alternately at the 7 segment display. This number corresponds to the digital display value which represents the minimum scale value, i.e. the point within the scale (SSt ... SEn) at which the light-strip starts.

This value can be changed with the \uparrow and \downarrow keys. A value which lies between SSt and SEn must be selected. Other values are not displayed. The selected value is saved to memory by pressing the P key, and the display is returned to the lower scale limit parameter.

Example:

Light-Strip Indicator (with reference to the digital display)				SSt (lower scale limit)	SEn (upper scale limit)	SOr (minimum scale value)
0	—————→	150	0	150	0	
0	←————	150	0	150	150	
100	—————→	0	100	0	100	
100	←————	0	100	0	0	
-150	←— 0 —→	150	-150	150	0	

The measuring instrument automatically calculates the corresponding parameters and returns to the normal operating mode. If no programming keys are activated for a period of more than 3.5 minutes, the measuring instrument automatically returns to the normal operating mode.

6.6 Measuring Range Matching for 0 ... 20 mA, 4 ... 20 mA and ± 20 mA

The parameters **ASt** and **AEn** allow for the entry of a display range without necessitating any further balancing. After selecting the measuring range, **ASt** and a **numeric value** blink alternately at the 7 segment display. Select the value which should be displayed as the measuring range lower limit with the \uparrow and \downarrow keys. Save the selected value to memory with the P key.

AEn and a **numeric value** then blink alternately at the 7 segment display. Select the value which should be displayed as the measuring range upper limit with the \uparrow and \downarrow keys. Save the selected value to memory with the P key.

The measuring instrument automatically calculates the corresponding parameters, and then displays the decimal point configuration window.

6.7 Measuring Range Matching with HCA (hardware calibration)

This selection allows for balancing with a calibrator. During balancing, input quantities must be applied to the instrument which correspond to the measuring range lower and upper limits.

After selecting the **HCA** function, **ZEr** and a **numeric value** blink alternately at the 7 segment display. Apply the value which corresponds to the measuring range lower limit to the measurement input. Use the \uparrow and \downarrow keys to select the value to be displayed at the measuring range lower limit. Save the selected value with the P key.

SPA and a **numeric value** blink alternately at the 7 segment display. Apply the value which corresponds to the measuring range upper limit to the measurement input. Use the \uparrow and \downarrow keys to select the value to be displayed at the measuring range upper limit. Save the selected value to memory with the P key.

The instrument automatically calculates the corresponding parameters, and displays the decimal point configuration window.

Attention:

If the calculated values for offset or scaling factor are not within the setting range, Err / InP appears at the 7 segment display. Exit the programming function with the P key.

6.8 Measuring Range Matching with PCA (software calibration)

Balancing is accomplished without a calibrator during measuring range matching with **PCA** by calculating offset and scaling factor. Offset and scaling factor are then set digitally by the instrument. After selecting the **PCA** function, **OFS** and a **numeric value** blink alternately at the 7 segment display. The offset value can be selected with the \uparrow and \downarrow keys. Save the selected value to memory with the P key. **SCA** and a **numeric value** then blink alternately at the 7 segment display.

Calculating Offset (OFS)

The offset value is the number of digits the display is shifted from the „normal“ zero point. The offset value (OFS) is calculated with the following equation without taking the decimal point into consideration:

$$OFS = ASt - \frac{MSt - (AEn - ASt)}{MEn - MSt}$$

ASt = display range lower limit

MSt = bottom of scale

AEn = display range upper limit

MEn = top of scale

Calculating Scaling Factor (SCA)

The scaling factor is used to match the display range to the scale range of the input signal. The scaling factor value (SCA) is calculated with the following equation without taking the decimal point into consideration:

$$SCA = SCA_{alt} * \frac{(MEn - MSt)_c}{(AEn - ASt)_a}$$

SCA old = scaling factor¹⁾

SCA = scaling factor²⁾

ASt old = displ. range l. limit¹⁾

ASt new = display range l. limit²⁾

AEn old = displ. range upper limit¹⁾

AEn new = display range upper limit²⁾

MSt old = start of meas. range¹⁾

MSt new = start of meas. range²⁾

MEn old = end of meas. range¹⁾

MEn new = end of meas. range²⁾

1) Value set prior to programming the measuring instrument.

2) Value to be set during re-programming the measuring instrument.

Example:

A measuring instrument has been configured as follows:
0 ... 10 V scale range corresponds to 0.0 ... + 99.9 display range. This configuration needs to be changed to the following:

2 ... 10 V scale range corresponds to - 10.0 ... + 99.9 display range.

ASt = -100 (without decimal point), MSt = 2V

AEn = 999 (without decimal point), MEn = 10V

This results in the following:

$$OFS = -100 - \frac{2 * (999 - (-100))}{10 - 2}$$

set to -375

$$SCA = 1 * \frac{(10 - 0)}{(999 - 0)} * \frac{(999 - (-100))}{(10 - 0)}$$

set to 1,38

6.9 Setting the Decimal Point

dP is displayed with the selected decimal point configuration.

Example:

dP. is displayed for the following decimal point configuration: xx.X

.dP is displayed for the following decimal point configuration: x.XX

dp is displayed for no decimal point, i.e. XXX

The desired decimal point configuration can be selected with the \uparrow and \downarrow keys. Save the selected value to memory with the P key.

6.10 Mean Value Generation and Display

Mean value generation and display, using from 0 (no mean value generation) to 32 values in discrete steps of 2, 4, 8 and 16, is provided for with the **FIL** function. This allows for the stabilization of fluctuating display values. The sampling rate is approximately 8 measurements per second.

6.11 Limit Value Function

The limit value function is selected immediately after light-strip settings have been completed. The selected limit value function appears at the 7 segment display. This setting is only available if the measuring instrument has been equipped with limit values (see specifications on serial plate or scale (Rel 1, Rel 2, Rel 3, Rel 4)).

The following functions can be selected:

Function	Parameter
Relay switching mode	nCL or nOP
Relay switching function	L-L, L-H, H-L or H-H
Relay switching hysteresis	HYS
Lock limit values	Loc or FrE

6.12 Relay Switching Mode

After the light-strip settings have been completed, the selected relay switching mode appears at the 7 segment display.

The desired switching mode (**nCL** or **nOP**) can be selected with the \uparrow and \downarrow keys. Save the selected value to memory with the P key.

6.13 Relay Switching Function

Depending upon the selected relay switching mode (**nCL** or **nOP**), the selected switching function appears at the 7 segment display (**L-L**, **L-H**, **H-H** or **H-L**):

- L-L** = All limit value relays indicate limit value violation if the measured values are less than the selected limit values.
- L-H** = Relay 1 (3) for limit value 1 (3) indicates limit value violation, if the measured value is less than the selected limit value 1 (3). Relay 2 (4) for limit value 2 (4) indicates limit value violation, if the measured value is greater than the selected limit value 2 (4).
- H-H** = All limit value relays indicate limit value violation if the measurement values are greater than the selected limit values.
- H-L** = Relay 1 (3) for limit value 1 (3) indicates limit value violation, if the measured value is greater than the selected limit value 1 (3). Relay 2 (4) for limit value 2 (4) indicates limit value violation, if the measured value is less than the selected limit value 2 (4).

The desired switching function can be selected with the \uparrow and \downarrow keys. Save the selected value to memory with the P key.

6.14 Setting Relay Switching Hysteresis

HYS and a **numeric value** blink alternately at the 7 segment display.

This value corresponds to the selected switching hysteresis in \pm digits.

Select the desired number of digits with the \uparrow and \downarrow keys. Save the selected value to memory with the P key.

7. Setting the Limit Values

The limit values can only be changed during operation if they haven't been locked in the programming mode. The limit values are accessed by simultaneously pressing the P and the \downarrow keys.

If **Loc** appears at the display, the instrument has been protected against limit value changes. No changes can be made in this case. The instrument is automatically returned to normal operation after approximately 3 minutes.

If the instrument has not been protected against limit value changes, the switching mode for the respective relay appears at the 7 segment display. The desired switching mode can be selected with the \uparrow and \downarrow keys, and the setting is saved to memory with the P key.

Depending upon the selected relay switching function (**nCL** or **nOP**), **Lo1** and a **numeric value**, or **Hi1** and a **numeric value** blink alternately at the 7 segment display. The displayed numeric value corresponds to limit value 1. The desired limit value can be selected at the 7 segment display with the \uparrow and \downarrow keys. Save the selected value to memory with the P key.

Depending upon the selected relay switching function, **Lo2** and a **numeric value**, or **Hi2** and a **numeric value** blink alternately at the 7 segment display. The displayed numeric value corresponds to limit value 2.

The desired limit value can be selected with the \uparrow and \downarrow keys. Save the selected value to memory with the P key, and the instrument is returned to normal operation.

7.1 Locking the Selected Limit Values

Either **FrE** or **Loc** appears at the 7 segment display.

FrE = Limit values can be changed, even if programming has been disabled by establishing an external connection between terminals 19 and 20.

Loc = If programming is disabled, the limit values cannot be changed, i.e. the limit values are locked if a connection has been established between terminals 19 and 20.

Select the desired value with the \uparrow and \downarrow keys. Save the selected value to memory with the P key.

The measuring instrument saves all settings to memory and the digital display on/off selection appears.

7.2 Switching the Digital Display On and Off

diS and **On**, or **diS** and **OFF** blink alternately at the 7 segment display. If **diS / On** is selected, the digital display remains active. If **diS / OFF** is selected, the digital display goes blank after the programming menu has been exited. Selection is made with the \uparrow and \downarrow keys. Save the selected value to memory with the P key and the instrument returns to normal operation.

Even if the digital display has been deactivated (**diS / OFF**), it is activated briefly for the duration of the following operations:

- Enter programming menu
- Change or query selected limit values
- Display test

8. Technical Data

Display

Type:	Analog	71 segment light strip 2 diodes for channel selection 2 diodes for limit values
	Digital	7 segment display, 3 digits with minus sign
Display Color		red
Light-Strip Height / Length		approx. 91 mm
Brightness		adjustable from 0 to 7
Display Range		-999 to 999
Character Height		approx. 8 mm
Polarity		displayed automatically
Decimal Point		programmable
Overload Display		— — —
Underload Display		— — —

Scale

Format	portrait
Scale Height / Length Scale	91 mm
Color	swan white
Graduation and Labelling	black

Input

Voltage Module

Input Impedance	>1M Ω for measurements > 2 V >70k Ω for measurements < 2 V
Current Module	
Voltage Drop	max. 2 V

Analog-Digital Conversion

Measuring Method	dual-slope
Sampling Rate	approx. 8 measurements per second
Measuring Time	approx. 40 ms

Error Limits

For Basic Device

Without Module

\pm (0.1% of reading + 2 digits)

DC Module

\pm (0.1% of reading + 2 digits)

Temperature Coefficient

< 150 ppm / K

SMRR

> 30 dB at 50 Hz

CMRR

> 120 dB related to
meas.range 200mV at 50Hz

Max. error for devices without digital display always:
 \pm 1.5 % of reading

Control Inputs

Device Test (Reset)

controlled via floating
contact

Freeze Display (Hold)

controlled via floating
contact

Disable Programming (Lock)

controlled via floating
contact

Relays

Contacts

1 changeover and 1
normally open contact each

Switching Capacity

5 A / 250 V AC

5 A / 30 V DC

Switching Time

max. 200 ms

Switching Hysteresis

adjustable from 0 to 100
digits

Power Supply

230 / 115 V AC 15%

50 / 60 Hz /

90 ... 260 V DC approx. 5 W

Electrical Safety

Types	IEC 61010-1 / EN 61010-1 / VDE 0411 Part 1
Safety Class	II
Overvoltage Category	CAT II
Contamination Level	2
Protection	IEC 60529 / EN 60529
Housing Front Panel	IP 65
Terminals	P 00

EMC

Interference Immunity	IEC 61326-1/+A1 EN 61326-1/ +A1
Interference Emission	IEC 61326-1/+A1 EN 61326-1/ +A1

Operating Voltage	300 V
--------------------------	-------

Ambient Conditions

Operating Temperature	0 ... 50 °C
Storage Temperature	-20 ... 70 °C
Relative Humidity	max. 85%
Vibration Resistance	IEC 61010-1/ EN 61010-1

Housing

Material	plastic, ABS
Front Dimensions	144 x 36
Panel Cutout	138 ⁺¹ x 33.0 ^{+0.6} mm
Panel Thickness	min. 1 to max. 45 mm
Bezel Height	5 mm
Installation Depth	max. 126 mm plus wiring
Weight	approx. 0.2 kg
Terminals	screw terminal blocks for wire with cross section of up to 2.5 square mm
Mounting	plastic mounting tabs
Factory setting	Range 4 ... 20 mA Bargraph 0 ... 100 Digital readout 0 ...99,9

Product Support

If required please contact:



Minchens Court
Bramley, RG26 5BH UK
www.metrix-electronics.com
sales@metrix-electronics.com

Subject to change without notice

Nov 2014

