

User manual TIMER SLC-94

- Firmware: v.1.12 or higher
- Input type: pulse
- Function of time counting and totalizer



Read the user's manual carefully before starting to use the unit or software.
Producer reserves the right to implement changes without prior notice.

SPIS TREŚCI

1. BASIC REQUIREMENTS AND USER SAFETY	3
2. GENERAL CHARACTERISTICS	4
3. TECHNICAL DATA	4
4. DEVICE INSTALLATION	6
4.1. UNPACKING.....	6
4.2. ASSEMBLY.....	6
4.3. CONNECTION METHOD.....	8
4.4. MAINTENANCE.....	13
5. FRONT PANEL DESCRIPTION	13
6. PRINCIPLE OF OPERATION	14
6.1. COUNTING MODE.....	14
6.2. CONTROL OF RELAY OUTPUTS.....	16
7. DEVICE PROGRAMMING	16
7.1. PROGRAMMING MENU.....	16
7.1.1. parameters edition.....	17
7.1.2. Numeric parameters (digit change mode).....	17
7.1.3. Numeric parameters (slide change mode).....	18
7.1.4. Switch parameters ("LIST" type).....	18
7.2. MENU DESCRIPTION.....	19
7.2.1. "rELAY1" ÷ "rELAY2" menu	19
7.2.2. „StArt" parameter.....	20
7.2.3. „StoP" parameter.....	20
7.2.4. "rESEt" parameter.....	20
7.2.5. Menu "diSPL".....	20
7.2.6. "PuSH" menu.....	21
7.2.7. "rS-485" menu.....	22
7.2.8. "briGHt" parameter.....	22
7.2.9. "SEtcod" parameter.....	23
7.2.10. "Edit t" parameter.....	23
7.2.11. "dEFS" parameter.....	23
7.3. MENU STRUCTURE.....	24
8. EXAMPLES OF TIME COUNTER CONFIGURATION	25
8.1. EXAMPLE 1 - CONTROLLING BY TRANSIENTS ON {START} LINE	26
8.2. EXAMPLE 2 - CONTROLLING BY STATE OF {START} LINE.....	26
8.3. EXAMPLE 3 - CONTROL USING THREE SOURCES.....	27
9. THE MODBUS PROTOCOL HANDLING	28
9.1. LIST OF REGISTERS.....	28
9.2. TRANSMISSION ERRORS DESCRIPTION.....	31
9.3. EXAMPLES OF QUERY/ANSWER FRAMES.....	31
10. DEFAULT AND USER'S SETTINGS LIST	34

Explanation of symbols used in the manual:



- This symbol denotes especially important guidelines concerning the installation and operation of the device. Not complying with the guidelines denoted by this symbol may cause an accident, damage or equipment destruction.

IF THE DEVICE IS NOT USED ACCORDING TO THE MANUAL THE USER IS RESPONSIBLE FOR POSSIBLE DAMAGES.



- This symbol denotes especially important characteristics of the unit. Read any information regarding this symbol carefully

1. BASIC REQUIREMENTS AND USER SAFETY



- **The manufacturer is not responsible for any damages caused by inappropriate installation, not maintaining the proper environmental conditions and using the unit contrary to its assignment.**
- Installation should be conducted by qualified personnel . During installation all available safety requirements should be considered. The fitter is responsible for executing the installation according to this manual, local safety and EMC regulations.
- GND input of device should be connected to PE wire;
- The unit must be properly set-up, according to the application. Incorrect configuration can cause defective operation, which can lead to unit damage or an accident.
- **If in the case of a unit malfunction there is a risk of a serious threat to the safety of people or property additional, independent systems and solutions to prevent such a threat must be used.**
- **The unit uses dangerous voltage that can cause a lethal accident. The unit must be switched off and disconnected from the power supply prior to starting installation of troubleshooting (in the case of malfunction).**
- Neighbouring and connected equipment must meet the appropriate standards and regulations concerning safety and be equipped with adequate overvoltage and interference filters.
- **Do not attempt to disassemble, repair or modify the unit yourself. The unit has no user serviceable parts. Defective units must be disconnected and submitted for repairs at an authorized service centre.**



- In order to minimize fire or electric shock hazard, the unit must be protected against atmospheric precipitation and excessive humidity.
- Do not use the unit in areas threatened with excessive shocks, vibrations, dust, humidity, corrosive gasses and oils.
- Do not use the unit in areas where there is risk of explosions.



- Do not use the unit in areas with significant temperature variations, exposure to condensation or ice.
- Do not use the unit in areas exposed to direct sunlight.
- Make sure that the ambient temperature (e.g. inside the control box) does not exceed the recommended values. In such cases forced cooling of the unit must be considered (e.g. by using a ventilator).



The unit is designed for operation in an industrial environment and must not be used in a household environment or similar.

2. GENERAL CHARACTERISTICS

SLC-94 is designed for precision time (period) measurements, e.g. duration of time interval and measurements of machine's operating time. Signals from push-buttons or contactors of control devices are connected to the terminals placed on back side of the counter. Properly programmed counter allows to measure time period between { START } and { STOP } signals. Other configuration allows to measure the activity time of { START } signal (line { STOP } is then unused). In addition the measure can be started, stopped and cleared using local keyboard (on front of the device) or via RS-485 interface.

Apart from basic function of time counting, totalizer is also available. Both counters, main timer and totalizer are triggered and stopped simultaneously. Time counting is realised in range 0 ms to 99 999.9 hours (maximum possible value). The device ensures a wide range of precision and presentation formats of timer and totalizer.

Build in two relay outputs allow use of this counter for control in many time depend processes.

Build in RS-485 interface allows full control and programming of the device.

3. TECHNICAL DATA

Power supply voltage (depending on version)	85... 230 ...260V AC/DC; 50 ÷ 60 Hz (separated)
External fuse (required)	19... 24 ...50V DC and 16... 24 ...35V AC (separated)
Power consumption	T - type, max. 2 A max. 4,5 VA @ 85 ÷ 260V AC/DC max. 4,5 VA @ 16V ÷ 35V AC max. 4,5 W @ 19V ÷ 50V DC
Pulse inputs (galvanic isolated)	
START input	counting enable (terminal no. 17)
STOP input	counting stop (terminal no. 18)
RESET input	clear counter (terminal no. 19)
COM	common terminal (terminal no. 20)
Input levels	
low:	0 V ÷ 3 V
high:	10 V ÷ 30 V
Inputs sampling frequency	> 10kHz

Minimum time between input signals edges	500µs
Outputs	
relay:	2 NO 1A/250V AC (cos φ = 1)
or OC-type:	2 max. 30mA / 30VDC / 100mW
sensor power supply:	24V +5% -10% / max. 100 mA, stabilized
Displaying values range	depending on display format main timer: max. from 0 ms to 999 99.9 hours totalizer: max. from 0 sec. to 999 99.9 hours
Precision	± 0,005 % of displayed value (at 25°C)
Temperature stability	± 0,005 % (at 0°C to +50°C)
Resolution	1 ms
Communication interface	RS 485, 8N1 / Modbus RTU, not separated
Baud rate	1200 bit/s ÷ 115200 bit/s
Display	LED, 4 digit, 20mm height, red
Protection level	IP 65 (from front, after using waterproof cover) IP 40 (from front) IP 20 (housing and connection clips)
Housing type	panel
Housing material	NORYL - GFN2S E1
Housing dimensions	96 x 48 x 100 mm
Panel cutout	90,5 x 43 mm
Assembly depth	102 mm
Panel thickness	max. 5 mm
Operating temperature	0°C to +50°C
Storage temperature	-10°C to +70°C
Humidity	5 to 90% no condensation
Altitude	up to 2000 meters above sea level
Screws tightening max. torque	0,5 Nm
Max. connection leads diameter	2,5 mm ²
Safety requirements	according to: PN-EN 61010-1 installation category: II pollution degree: 2 voltage in relation to ground: 300V AC insulation resistance: >20MΩ insulation strength between power supply and input/output terminal: 1min. @ 2300V insulation strength between relays terminal: 1min. @ 1350V
EMC	PN-EN 61326-1



This is a class A unit. In housing or a similar area it can cause radio frequency interference. In such cases the user can be requested to use appropriate preventive measures.

4. DEVICE INSTALLATION

The unit has been designed and manufactured in a way assuring a high level of user safety and resistance to interference occurring in a typical industrial environment. In order to take full advantage of these characteristics installation of the unit must be conducted correctly and according to the local regulations.



- Read the basic safety requirements on page 3 prior to starting the installation.
- Ensure that the power supply network voltage corresponds to the nominal voltage stated on the unit's identification label.
- The load must correspond to the requirements listed in the technical data.
- All installation works must be conducted with a disconnected power supply.
- Protecting the power supply clamps against unauthorized persons must be taken into consideration.

4.1. UNPACKING

After removing the unit from the protective packaging, check for transportation damage. Any transportation damage must be immediately reported to the carrier. Also, write down the unit serial number on the housing and report the damage to the manufacturer.

Attached with the unit please find:

- assembly brackets - 2 pieces,
- warranty,
- user's manual for **SLC-94** unit (device)

4.2. ASSEMBLY



- The unit is designed for mounting inside housings (control panel, switchboard) insuring appropriate protection against surges and interference. Metal housings must be connected to ground in a way that complies with the governing regulations.
- Disconnect the power supply prior to starting assembly.
- Check the connections are wired correctly prior to switching the unit on.



In order to install the unit, a 90.5 x 43 mm mounting hole (Figure 4.1, 4.2) must be prepared. The thickness of the material of which the panel is made must not exceed 5mm. When preparing the mounting hole take the grooves for catches located on both sides of the housing into consideration (Figure 4.1, 4.2). Place the unit in the mounting hole inserting it from the front side of the panel, and then fix it using the brackets (Figure 4.3). The minimum distances between the centre points of multiple units - due to the thermal and mechanical conditions of operation - are 115 mm x 67mm (Figure 4.4).

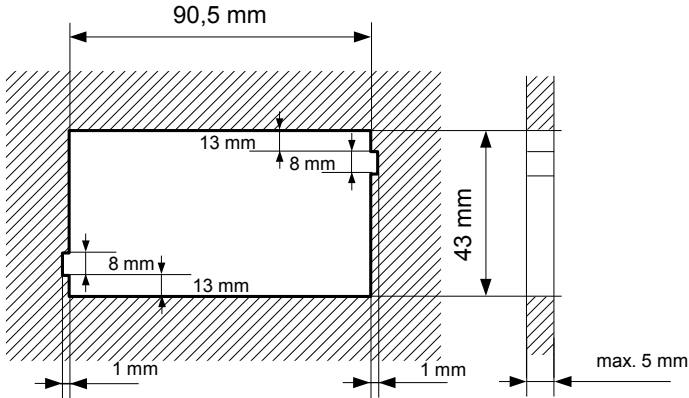

Figure 4.1. Recommended mounting hole dimensions

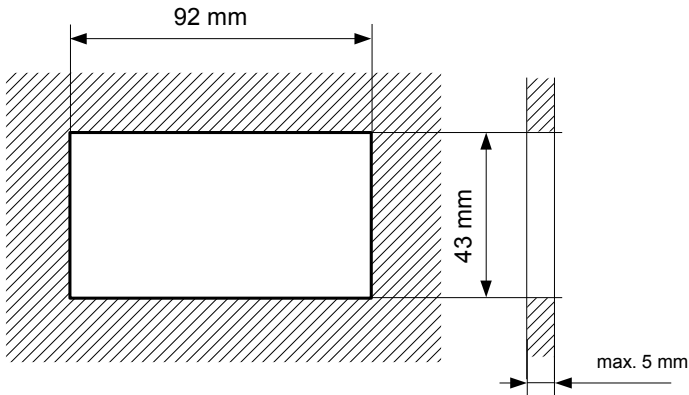

Figure 4.2. Allowable mounting hole dimensions

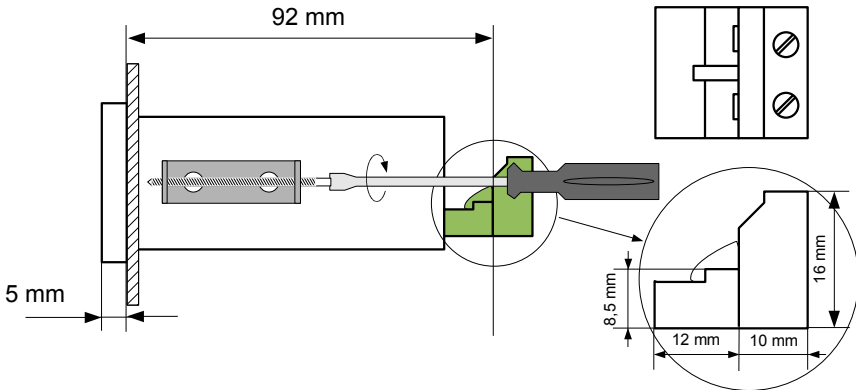

Figure 4.3. Installing of brackets, and dimensions of connectors.

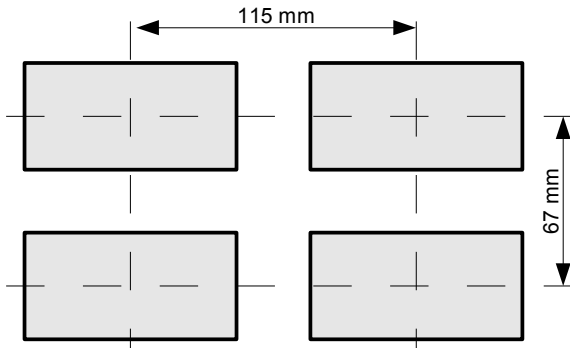

Figure 4.4. Minimum distances when assembly of a number of units

4.3. CONNECTION METHOD

Caution



- Installation should be conducted by qualified personnel . During installation all available safety requirements should be considered. The fitter is responsible for executing the installation according to this manual, local safety and EMC regulations.

- The unit is not equipped with an internal fuse or power supply circuit breaker. Because of this an external time-delay cut-out fuse with minimal possible nominal current value must be used (recommended bipolar, max. 2A) and a power supply circuit-breaker located near the unit. In the case of using a monopolar fuse it must be mounted on the phase cable (L).



- The power supply network cable diameter must be selected in such a way that in the case of a short circuit of the cable from the side of the unit the cable shall be protected against destruction with an electrical installation fuse.

- Wiring must meet appropriate standards and local regulations and laws.

- In order to secure against accidental short circuit the connection cables must be terminated with appropriate insulated cable tips.
- Tighten the clamping screws. The recommended tightening torque is 0.5 Nm. Loose screws can cause fire or defective operation. Over tightening can lead to damaging the connections inside the units and breaking the thread.
- In the case of the unit being fitted with separable clamps they should be inserted into appropriate connectors in the unit, even if they are not used for any connections.
- **Unused clamps (marked as n.c.) must not be used for connecting any connecting cables (e.g. as bridges), because this can cause damage to the equipment or electric shock.**
- If the unit is equipped with housing, covers and sealing packing, protecting against water intrusion, pay special attention to their correct tightening or clamping. In the case of any doubt consider using additional preventive measures (covers, roofing, seals, etc.). Carelessly executed assembly can increase the risk of electric shock.
- After the installation is completed do not touch the unit's connections when it is switched on, because it carries the risk of electrical shock.

Due to possible significant interference in industrial installations appropriate measures assuring correct operation of the unit must be applied. To avoid the unit of improper indications keep recommendations listed below.

- Avoid common (parallel) leading of signal cables and transmission cables together with power supply cables and cables controlling induction loads (e.g. contactors). Such cables should cross at a right angle.
- Contactor coils and induction loads should be equipped with anti-interference protection systems, e.g. RC-type.
- Use of screened signal cables is recommended. Signal cable screens should be connected to the earthing only at one of the ends of the screened cable.
- In the case of magnetically induced interference the use of twisted couples of signal cables (so-called "spirals") is recommended. The spiral (best if shielded) must be used with RS-485 serial transmission connections.
- In the case of measurement or control signals are longer than 30m or go outside of the building then additional safety circuits are required.
- In the case of interference from the power supply side the use of appropriate anti-interference filters is recommended. Bear in mind that the connection between the filter and the unit should be as short as possible and the metal housing of the filter must be connected to the earthing with largest possible surface. The cables connected to the filter output must not run in parallel with cables with interference (e.g. circuits controlling relays or contactors).

Connections of power supply voltage and measurement signals are executed using the screw connections on the back of the unit's housing (Figure 4.5 - 4.6).

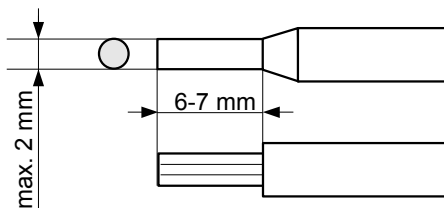

Figure 4.5. Method of cable insulation replacing and cable terminals



All connections must be made while power supply is disconnected !

16
31

Double numeration means, that depending on device version, particular terminal can be marked according to the top or bottom number.

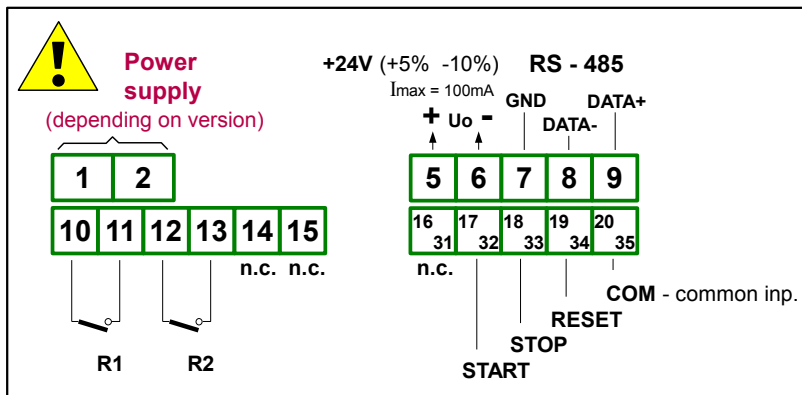

Figure 4.6. Terminals description (relay outputs)

Description of input terminals

- { **START** } - counting enable;
- { **STOP** } - counting stop (without clearing the counter value);
- { **RESET** } - counter clearing;
- { **COM** } - common terminal

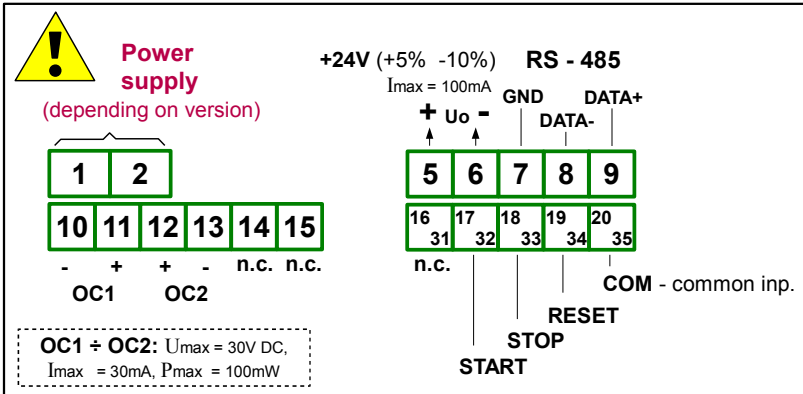

Figure 4.7. Terminals description (OC-type outputs)

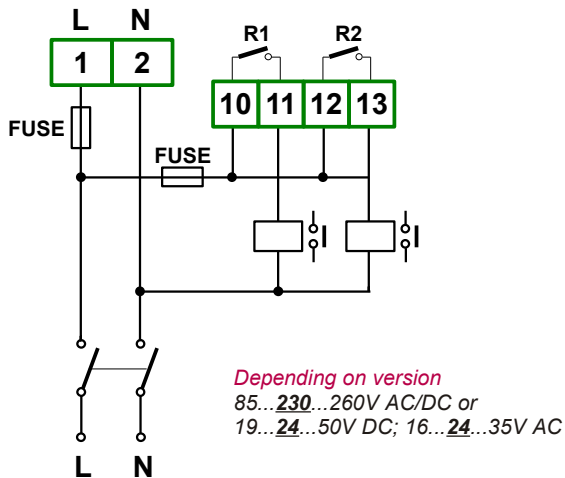

Figure 4.8. Connection of power supply



Contacts of relay outputs are not equipped with spark suppressors. While use the relay outputs for switching of inductive loads (coils, contactors, power relays, electromagnets, motors etc.) it is required to use additional suppression circuit (typically capacitor 47nF/ min. 250VAC in series with 100R/5W resistor), connected in parallel to relay terminals or (better) directly on the load. In consequence of using the suppression circuit, the level of generated electromagnetic disturbances is lower, and the life of relay contacts rises.

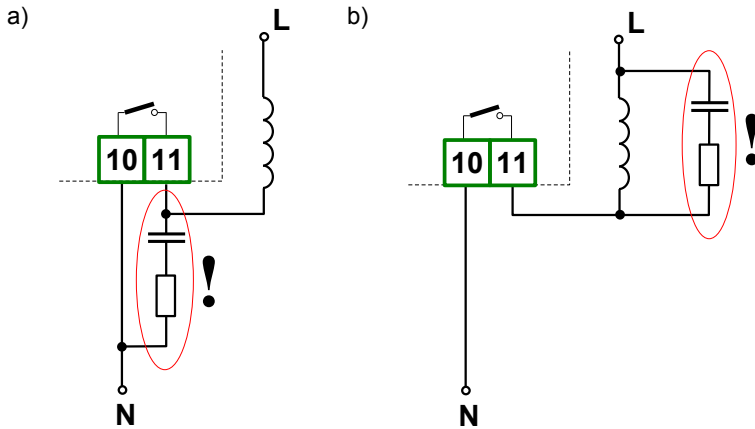

Figure 4.9. Examples of suppression circuit connection:
 a) to relay terminals; b) to the inductive load

It is possible to use external power supply in place of internal sensor supply U_s (Figure 4.6). Closed contacts of external switch (while current flow) is equal to active state (marked „Hi”) of the input , and open contacts (no current) inactive state (marked „Lo”).

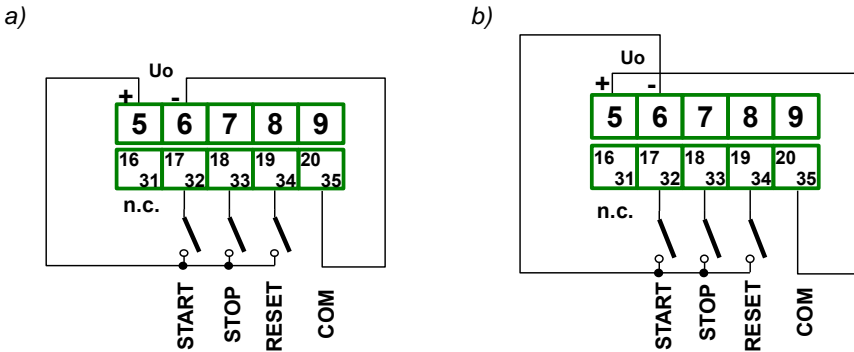

Figure 4.10. Example of input terminals connection:
 a) with ground on common terminal, b) with supply on common terminal

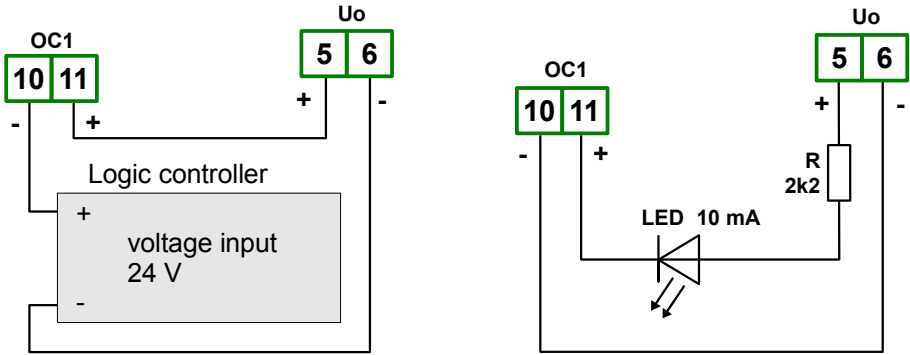

Figure 4.11. Example of OC-type outputs connection

4.4. MAINTENANCE

The unit does not have any internal replaceable or adjustable components available to the user. Pay attention to the ambient temperature in the room where the unit is operating. Excessively high temperatures cause faster ageing of the internal components and shorten the fault-free time of unit operation.

In cases where the unit gets dirty do not clean with solvents. For cleaning use warm water with small amount of detergent or in the case of more significant contamination ethyl or isopropyl alcohol.



Using any other agents can cause permanent damage to the housing.



Product marked with this symbol should not be placed in municipal waste. Please check local regulations for disposal and electronic products.

5. FRONT PANEL DESCRIPTION



Symbols and functions of push-buttons



Symbol used in the manual: **[ESC/MENU]**

Functions:

- Enter to main menu (press and hold by at least 2 sec.)
- Exit the current level and Enter to previous menu (or measure mode)
- Cancel the changes made in parameter being edited



Symbol used in the manual: **[ENTER]**

Functions:

- Start to edit the parameter
- Enter to the sub-menu,
- Confirmation of changes made in parameter being edited
- switches display between main timer and totalizer values



Symbol used in the manual: **[^] [v]**

Functions:

- Change of the present menu,
- Modification of the parameter value,
- Start / Stop counting,



Symbol used in the manual: **[RESET]**

Functions:

- clearing of currently displayed counter - timer or totalizer (only if "PuSH" option is active), requires of acknowledgment by **[ENTER]** button.

6. PRINCIPLE OF OPERATION

After turning the power supply on, device ID and software version are showed on the display, next the controller goes to the counting mode and displays timer (main or totalizer) which were showed before power down.

6.1. COUNTING MODE

In counting mode the result of main timer (or totalizer) is continuously presented on LED display. Active signal on { **START** } input, initializes counting. Active signal on { **STOP** } causes in holding of counting without clearing of the result. Another active { **START** } pulse restarts counting from previous value (if the result has not been cleared by active { **RESET** } signal).

After the counter reaches maximum value of present format of presentation, a message "**-Hi-**" is displayed in place of the result. If counted value is not bigger than 99999.9 hours counting is not stopped, and current value can be displayed by changing of presentation format, or resolution of measurement ("**C-PrEC**", "**C-diSP**" parameters for main timer and "**t-diSP**" parameter for totalizer) . For example: "**C-PrEC**" = 0.0, "**C-diSP**" = „**h-m-S**" overload (message "**-Hi-**") will come after 10 hours. Change of "**C-PrEC**" to "0." will cause in displaying of actual result (but resolution will be changed from 100 ms to 1 sec.).



Parameter "**C-PrEC**" has no any effect in the formats : „**h-m**“, „**h-h10**".

Signal { **RESET** } clears only main timer, totalizer value stay not changed. Control signals { **START** } & { **STOP** } control triggering and stopping of both counters (main timer and totalizer) simultaneously

After value 99999.9 hours is exceeded the device displays message "**ovEr**" in place of value, but counting is not stopped, and its current value can be read via RS-485 interface.

Enabling / disabling and clearing of the counting can be done via galvanic isolated inputs (according to settings), using local keyboard (if option "**PuSH**" has been set to "**on**") or via RS-485 interface.



Starting, stopping, and clearing of the counter via serial interface is affected by delay errors, depends on transmission speed and parameter „**rESP**". Example minimum delay while „**Baud**" = **9.600** and "**rESP**" = **Std** equals about 14ms. The delay can be calculated using formula:

$$t_{D \min} = 10\,000 \times \frac{13 + "rESP"}{"bAud"} \quad [\text{milliseconds}]$$

$t_{D \min}$ - minimum delay (for „**rESP**" = „**Std**" use „**rESP**" = 0.)

The functions of keyboard while normal operation:



START of counting (while "**PuSH**" is active). Button inactive if parameter "**StArt**" has been set to "**Lo**" or "**Hi**".



STOP of counting (while "**PuSH**" is active). Button inactive if parameter "**StArt**" has been set to "**Lo**" or "**Hi**".



Manual clearing of currently displayed counter - timer or totalizer, requires of acknowledgement by [**ENTER**] button.



switches display between main timer and totalizer values



Enter to menu programming mode (press and hold at least 2 seconds).



- The counting is independent of operation mode. After entering menu mode device keep counting, it is made in background;
- In case of power fail, after next power-on device is stopped. Main timer and totalizer shows their values stored while power-off. Proper configuration of the inputs allows counting directly after power on.

6.2. CONTROL OF RELAY OUTPUTS

Controlling of external devices up on **main timer** and totalizer values is possible thanks to build in relay outputs. The operation principle of relay output is defined by parameters: **“SEtP”**, **“modE”**, **“Src”**.

Parameter **“SEtP”** defines the **threshold** of an relay. Setting of threshold is made by entering values of parameters **“Hr”**, **“min”**, **“SEc”**, **“mSEc”**. Note, that the sum of all of these parameters decides what is exact threshold value.

Example 1:

Setting **“Hr”**=2, **“min”**=30, **“SEc”**=40, **“mSEc”**=567 causes that relay will be activated after 2 hours , 30 minutes, 40 seconds and 567 milliseconds.

Example 2:

Setting **“Hr”** =1, **“min”** = 65 , **“SEc”**=0, **“mSEc”**=0 causes that relay will be activated after 2 hours and 5 minutes .

While controlling process relay output can change its state to **active** only after the counter reach its threshold value. Active state of the relay (closed or opened) is defined by parameter **“modE”**. The selection of controlling counter (main timer or totalizer) is realised by parameter **“Src”**.



The action related to **threshold value** is not immediate. Maximum delay (activation or deactivation while controlled by main timer) is less than 12 ms for OC outputs and up to 20ms for electromechanical relays.

If **“Src”** parameter equals **“total”** then **“mSEc”** parameter in relay threshold edition menu (**“SEtP1”** i **“SetP2”**) is non active and equals zero.

All parameters connected with relay outputs are described in paragraph **“rEL1”** and **“rEL2”** *menu*.

7. DEVICE PROGRAMMING

The device menu allow user to set all parameters connected to operation of counting input, reset source, displaying format, communication via RS-485 and access settings. The meaning of the particular parameters is described in paragraph **MENU DESCRIPTION**.

7.1. PROGRAMMING MENU

To enter main menu (being in the measurement mode) operator must to press and hold at least 2 sec. **[ESC/MENU]** button.

If the user password is defined (see parameter “**SEtcod**”), operator have to enter correct one before proceeding to menu options. Entering of the passwords is similar to the edition of numeric parameters (see: **PARAMETERS EDITION**), however presently editing digit is showed only on the display, other digits are replaced by “-” sign. After entering of last digit of the password first menu position will be displayed (if the password is correct) or warning “**Error**” in other case.

After entering menu mode, buttons change its meaning (see table below), independent of “**PuSH**” parameter settings (it means, even if they are used to control time measurement). After exiting menu buttons can be used to control measurement again.

Functions of the buttons while sub-menu and parameters choice:



Selection of sub-menu or parameter for editing. Name of selected item (sub-menu or parameter) is displayed.



Operation of **[ENTER]** button depend on present menu position:

- if the name of some sub-menu is displayed - enter this sub-menu; name of the first parameter (or next level sub-menu) is displayed,
- if the name of some parameter is displayed - enter the edition of this parameter; present value of the parameter is displayed,



[ESC/MENU] button allow user to exit present menu level and goes to upper level menu (or measurement mode).



After about 1 min. since last use of the buttons, device exits the menu mode and returns to the measurement mode (only if no parameters are in editing mode).

7.1.1. parameters edition

To start edition of any parameter user should select name of desired one using **[^]** **[v]** buttons and then press **[ENTER]**.

7.1.2. Numeric parameters (digit change mode)

Numerical parameters are displayed as decimal numbers. The mode of its new value entering depends on chosen edit method (see parameter „**Edit**”).

In mode “by digit” („**Edit**”=“**dig**”) pressing one of the keys **[^]** or **[v]** causes change of current position (flashing digit) or the sign (+/-). Short pressing of the **[ENTER]** button causes change of the position (digit).

Press **[ENTER]** at least 2 seconds to accept the changes, after that question “**SEt?**” is displayed, and user must to confirm (or cancel) the changes. To conform changes (and store it in EEPROM) press **[ENTER]** button shortly after “**SEt?**” is displayed. To cancel the changes press **[ESC]** button shortly after “**SEt?**” is displayed. After that device returns to the menu.

7.1.3. Numeric parameters (slide change mode)

In “slide change” mode („Edit”=“Slid”), buttons [^] and [v] has different functions.

To increase edited value press (or press and hold) [^] button only, the increasing became quickest as long as button [^] is pressed. To slow down the increasing, button [v] can be used. If [v] is pressed shortly (and button [^] is still pressed), increasing slow down for a moment only, if [v] is pressed and held while button [^] is still pressed the increasing slow down and will be kept on lower speed.

To decrease edited value press (or press and hold) [v] button only. The decreasing became quickest as long as button [v] is pressed. To slow down the decreasing, button [^] can be used. If [^] is pressed shortly (and button [v] is still pressed), decreasing slow down for a moment only, if [^] is pressed and held while button [v] is still pressed the decreasing slow down and will be kept on lower speed.

Press [ENTER] at least 2 seconds to accept the changes, after that question ”Set?” is displayed, and user must to confirm (or cancel) the changes. To conform changes (and store it in EEPROM) press [ENTER] button shortly after ”Set?” is displayed. To cancel the changes press [ESC] button shortly after ”Set?” is displayed. After that device returns to the menu.

7.1.4. Switch parameters (“LIST” type)

Switch parameters can be described as a sets of values (a lists) out of which only one of the options available on the list can be selected for the given parameter. Options of switching parameter are selected using [^], [v] keys.

Short pressing of [ENTER] causes in displaying of the acknowledge question (”Set?”). If key [ENTER] is pressed again, the changes are accepted, stored in EEPROM end the edition process finished. Pressing the key [ESC] after ”Set?” causes in cancelling of made changes and returning to menu.

Functions of buttons when editing numeric and switching parameters:



While editing numeric parameter:

- change of current (flashing) digit
 - slide change of value (acceleration, deceleration, direction change)
- While editing switch parameter - selection of switch parameter.



If numerical parameter is being edited, a short press of [ENTER] button change edited position. A long press of [ENTER] button (at least 2 sec.) causes of display a ”Set?” ask, which allow user to make sure if change of the parameter value is correct. If switch parameter is being edited, a short press of [ENTER] button causes of display a ”Set?” ask. When [ENTER] button is pressed again (while ”Set?” is displayed) the new value of the parameter is stored in EEPROM memory.



Pressing this button operator can cancel the changes done up to now (if they were not approved by [ENTER] button after the ”Set?” ask) and come back to menu



To store new value of changed parameter press [ENTER] after question ”Set?” is displayed on the display, to cancel changes press any other key.

7.2. MENU DESCRIPTION

“- . . . -” Password checking. If any password different from „0000” is set, than every enter to main menu follows the entering of password. If entered password is correct first menu position will be displayed else warning **“Error”**, and unit returns to measurement mode.



Due to problem with direct displaying of “m” letter, it is exchanged with special sign “ñ”. Independently in user manual letter “ñ” is used to make it more readable (example: “**modE**”).

7.2.1. “rELAy1” ÷ “rELAy2” menu

This menu allows to configure the operation mode of relays and LEDs marked „R” (e.g. „R1”). If there are few relay outputs available, then every output has its own configuration menu (e.g. menu „rEL2” for relay (LED) „R2”). Principle of the relays operation is described in paragraph **CONTROL OF THE RELAY OUTPUTS**.

“SEtP 1” ÷ “SEtP 2” - setting of relay threshold . The threshold value is edited by all parameters below together:

“Hr”	- hours, range 0 ÷ 99 999,
“min”	- minutes, range 0 ÷ 999 999,
“SEc”	- seconds, range 0 ÷ 999 999,
“mSEc”	- milliseconds, range 0 ÷ 999 999.

the sum of all of these parameters decides what is exact threshold value. Detailed description of threshold value setting method is described in paragraph 6.2

If “Src” parameter equals “total” then “mSEc” parameter in relay threshold edition menu (“SEtP1” i “SEtP2”) is non active and equals zero.

“modE 1” ÷ “modE 2” - operation mode. Defines active state of the relay, that means state after counter reached threshold value. Following values are available:

“noACt”	- not active (relay permanently opened)
“on”	- relay closes when counter reaches threshold value
“oFF”	- relay opens when counter reaches threshold value

“Src 1”, “Src 2” - control source, this parameter allows to select what counter (main timer or totalizer) has to control particular relay, available values:

„curr”	- main timer controls relay
„total”	- totalizer controls relay



Closed contactors of an relay are indicated by lighted Led.

7.2.2. „StArt” parameter

This parameter defines the method of starting the counting (apply to configuration of { **START** } input).

“Lo-Hi”, “Hi-Lo” - selection of edge starting the measurement:

”Lo-Hi” - rising edge (from low to high state),

”Hi-Lo” - falling edge (from high to low state),

“Lo”, “Hi” - selection of level starting the measurement:

”Lo” - low, “Hi” - high. After selection one of these options { **STOP** } input and [^] [v] buttons are inactive, there is no parameter “**StoP**” in the menu, and it is impossible to start / stop counting via RS-485 interface.

Examples are shown in paragraph 8 on page 25.

7.2.3. „StoP” parameter

This parameter defines the method of stopping the measurement (apply to configuration of { **STOP** } input). Possible values:

“Lo-Hi” - rising edge (from low to high state) stops counting,

“Hi-Lo” - falling edge (from high to low state) stops counting.

Examples are shown in paragraph 8 on page 25.

7.2.4. “rESEt” parameter

This parameter defines the method of clearing the counter (apply to configuration of { **RESET** } input). Possible values:

“Lo-Hi”, “Hi-Lo” - selection of edge :

”Lo-Hi” - rising edge (from low to high state) ,

”Hi-Lo” - falling edge (from high to low state).

“Lo”, “Hi” - selection of state:

”Lo” - low,

”Hi” - high.

Examples are shown in paragraph 8 on page 25.

7.2.5. Menu “diSPL”

This menu allows to set displaying formats of main timer and totalizer.

„**C-diSP**” - this parameter defines displaying format of main timer. Possible values:

“**SEc**” - time displayed in format “**seconds . milliseconds**”

“**h-m-S**” - time displayed in format “**hours . minutes . seconds . milliseconds**”

“**h-m**” - time displayed in format “**hours . minutes** (seconds are recalculated to hours and minutes)

“**h-h10**” - time displayed in format “**hours . fractional part of hour**” .

„**C-PrEC**” - this parameter sets precision of main timer displayed time.

“0.000”, “0.00”, “0.0”, “0.” - from 1 ms to 1 sec respectively

This parameter do not concern formats : “h-m” lub “h-h10”.

Combinations of parameters „**C-diSP**” and „**C-PrEC**” allow to set several formats and ranges of main timer:

„ C-PrEC ”	„ C-diSP ”	Displaying range	Format	The unit for last displayed digit
„SEC”	„0.000”	000.000 ÷ 999.999	sec.milliseC	1 millisecond
„SEC”	„0.00”	0000.00 ÷ 9999.99	sec.milliseC	10 milliseconds
„SEC”	„0.0”	00000.0 ÷ 99999.9	sec.milliseC	100 milliseconds
„SEC”	„0.”	000000. ÷ 999999.	sec.	1 second
„h-m-S”	„0.000”	0.00.000 ÷ 9.59.999 (max 10min)	min.sec.milliseC	1 millisecond
„h-m-S”	„0.00”	00.00.00 ÷ 59.59.99 (max 60min)	min.sec.milliseC	10 milliseconds
„h-m-S”	„0.0”	0.00.00.0 ÷ 9.59.59.9 (max 10hour)	hour.min.sec.milliseC	100 milliseconds
„h-m-S”	„0.”	00.00.00. ÷ 99.59.59. (max 100hour)	hour.min.sec.	1 second
„h-m”	do not concern	0.00.00.0 ÷ 9999.59 (max godz)	hour.min..	1 minute
„h-h 10”	do not concern	00.00.00. ÷ 99999.9 (max godz)	hours .fractional part of hour	fractional part of hour

„**t-diSP**” - this parameter defines displaying format of main timer. Possible values:

“**h-m-S**” - time displayed in format “**hours . minutes . seconds**”

“**h-m**” - time displayed in format “**hours . minutes**
(seconds are recalculated to hours and minutes)

“**h-h10**” - time displayed in format “**hours . fractional part of hour**” .



These settings are corresponded to method of displaying of the result. Internal precision of counting is invariable and equals 1ms.

7.2.6. “PuSH” menu

This parameter allows to enable/disable control of measurements via keyboard. Following values are available:

“**oFF**” - control of measurements using local keyboard is disabled (this is default value)

“**on**” - control of measurements using local keyboard is enabled (control)

7.2.7. "rS-485" menu

This menu is connected with RS-485 interface, and sets his properties:

- "Addr"** - this parameter defines the address of the device, accordingly to Modbus protocol. It can be set in range from 0 to 199. If the value 0 is set then device, responds to frames with address 255 (FFh).
- "bAud"** - this parameter determines RS-485 interface baud rate. It can be set to one of 8 possible values: **"1200"**, **"2400"**, **"4800"**, **"9600"**, **"19200"**, **"38004"**, **"57600"**, **"115200"**.
- "mbAccE"** - this parameter sets the access to the configuration registers of the device. Possible values:
"on" - configuration registers can be set via RS-485 interface,
"oFF" - configuration registers can not be set via RS-485 interface.
- "rESP"** this parameter defines minimal (additional) delay between the Modbus message and the answer of the device (received and sent via RS-485 interface). Modbus protocol defines minimum delay between frames to 3.5 chars. Internal RISC processor of **SLC-94** allows get very fast responses. This additional delay allows the device to work with poor RS-converters which do not works properly on higher baud rates. Following values are available:

"Std" - answer as quick as possible, no additional delay

"10c"
"20c"
"50c"
"100c"
"200c"

} - answer delayed of 10, 20, 50, 100 of 200 chars respectively, where one character time depends on selected baud rate

In the most cases parameter **"rESP"** should be set to **"Std"** (no additional delay). Unfortunately for some third party RS-converters **"rESP"** should be adjusted experimentally. Table below contains most frequently used values.

Parameter "bAud"	"38.4"	"57.6"	"115.2"
Parameter "rESP"	"10c"	"20c"	"50c"

Tab.7.1. Settings of **"rESP"** parameter

7.2.8. "briGHt" parameter

This parameter allows user to set bright of the LED display, bright can be set to conventional values from 1 to 8.

7.2.9. "SEtcod" parameter

User password (4-digits number). If this parameter is set at value "0000", user password is turned off.

If the user do not remember his password, the access to the menu is possible by the "one-use password". To get this password please contact witch Marketing Division. Please set new user password immediately after use of the "one-use password" - see "SEtcod" parameter.



The "one-use password" can be used one time only, it is impossible to use it again! The "one-use password" can be restored by Service Division only.

7.2.10. "Edit t" parameter

This parameter allows to change the edition mode of numerical parameters:

- "dig"** - the change to "by digit" mode,
- "Slid"** - slide change mode.

7.2.11. "dEFS" parameter

This setting allows to restore the factory settings of the device. To get the access to this option special password is required: „5465“, next the device displays acknowledge question „SEt?“. Press **[ENTER]** to acknowledge the restoring of factory settings or **[ESC]** to cancel.

7.3. MENU STRUCTURE

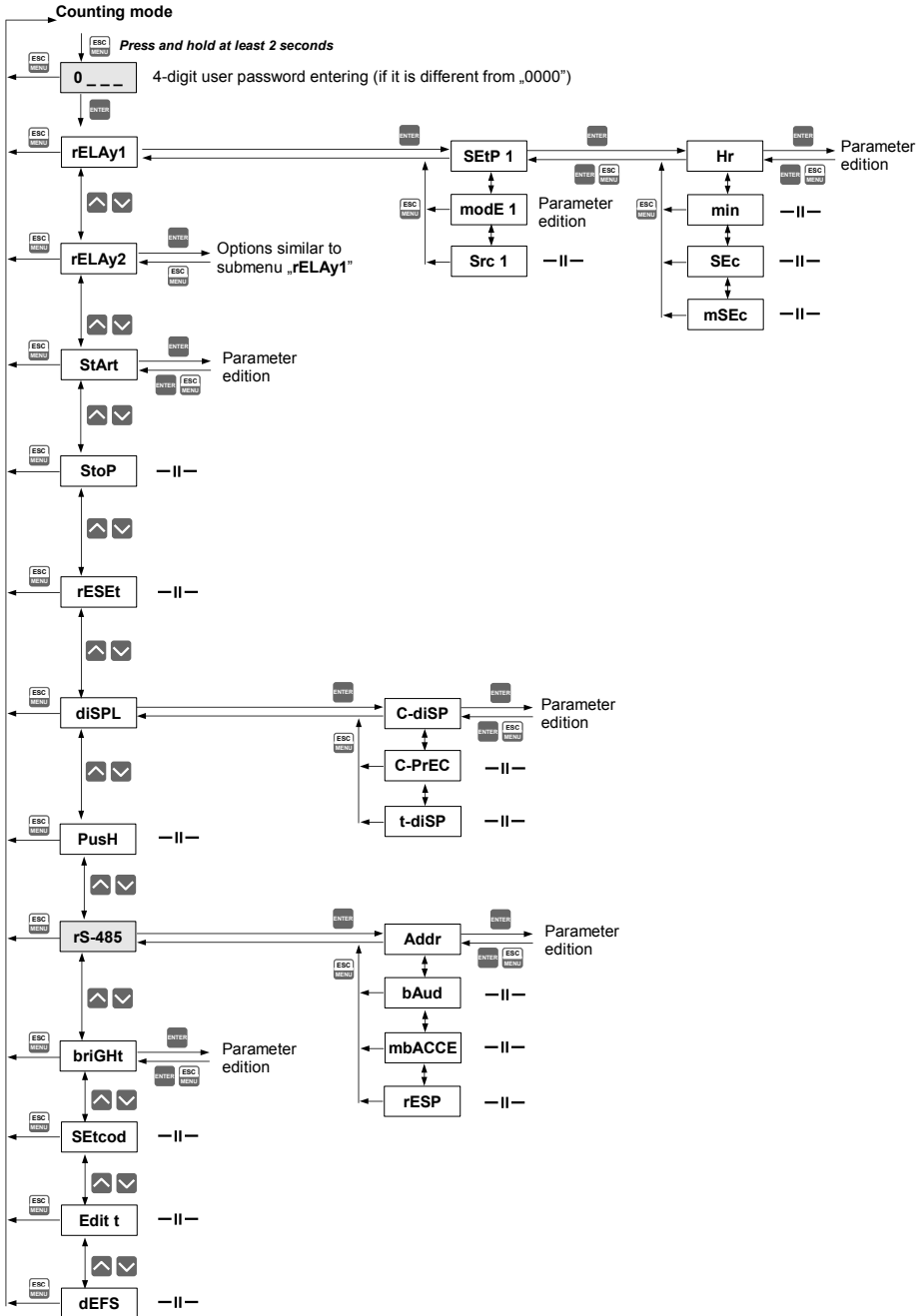

8. EXAMPLES OF TIME COUNTER CONFIGURATION

Due to big number of parameters some tasks must to be explained.

Starting the counting

If parameter start „**StArt**” has been set to „**Lo-Hi**” or „**Hi-Lo**” counting can be started in three ways:

- using external signal connected to terminal { **START** },
- using local keyboard and pressing button [**^**] (parameter „**PuSH**” must to be active)
- setting bit 0 of control word, using RS 485 interface (parameter „**mbAc**” must to be set “**on**”).

If parameter „**StArt**” has been set to „**Lo**” or „**Hi**” starting of the counter can be done exclusively using external signal { **START** }. Other possibilities are blocked.

Stopping the counting

If parameter „**StArt**” has been set to „**Lo-Hi**” or „**Hi-Lo**” stopping of the counter can be done in three ways:

- using external signal connected to terminal { **STOP** },
- using local keyboard and pressing button [**v**] (parameter „**PuSH**” must to be active)
- setting bit 1 of control word, using RS 485 interface (parameter „**mbAccE**” must to be set “**on**”).

If parameter „**StArt**” has been set to „**Lo**” or „**Hi**” stopping of the counter of the counter can be done exclusively using external signal { **START** }. Other possibilities are blocked.

Clearing of the counter

Clearing of main counter and totalizer can be made in one of following ways:

- using external signal { **RESET** } - main timer only.
- Pressing button [**RESET**] on counter front panel (if „**PuSH**” option is active) – currently displayed counter will be cleared only
- setting bit 2 of control word using RS 485 interface clears main timer (parameter „**mbAccE**” must to be set “**on**”).
- setting bit 2 of control word, using RS 485 interface clears totalizer (parameter „**mbAccE**” must to be set “**on**”).

It is possible to control the counter from more than one source during one measurement for example:

- starting is done using local keyboard, and stopping using RS 485 interface;
- starting by external signal { **START** }, clearing via RS 485 interface and stopping using local keyboard

It is possible to disable control of the counter from local keyboard or RS 485 interface, by setting corresponded parameters in programming menu.



Clearing of the counter do not stop the counting.

If parameter „**rESEt**” has been set to „**Lo**” or „**Hi**” and start of the counting (from any source) occurs while signal { **RESET** } is in active state, then counting starts after { **RESET** } line will change its state.

8.1. EXAMPLE 1 - CONTROLLING BY TRANSIENTS ON {START} LINE

Settings:

„StArt” = „Lo-Hi”

„StoP” = „Hi-Lo”

„rESEt” = „Hi”

The counting starts after rising edge occurs on { **START** } line. Falling edge on { **STOP** } line stops counting, however content of both , main timer and totalizer stay unchanged.

Next edge on { **START** } line restarts counting. Active state on { **RESET** } line clears counter asynchronously.

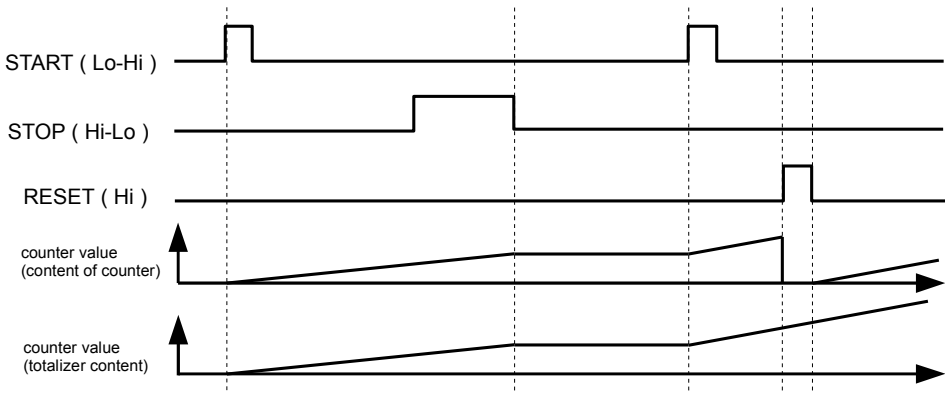
**8.2. EXAMPLE 2 - CONTROLLING BY STATE OF {START} LINE**

Settings:

„StArt” = „Hi”

„rESEt” = „Lo-Hi”

Counting runs while high level occurs on { **START** } line. Low state on this line stops counting. None change on { **STOP** } line has influence on counter content (counting is fully controlled via { **START** } and { **RESET** } lines). Rising edge on { **RESET** } line clears main timer (totalizer stay unchanged), after that counting is continued from 0 if the state of { **START** } line is still high.

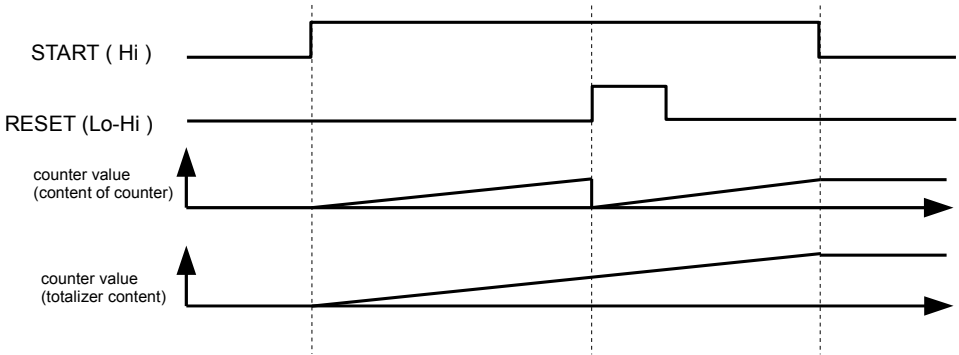

8.3. EXAMPLE 3 - CONTROL USING THREE SOURCES

Settings:

„StArt” = „Hi-Lo”

„PuSH” = „on” (keyboard control enabled)

„mbAccE” = „on” (writing Modbus registers enabled)

Counting is started after falling edge on { **START** } line. Pressing [**v**] button stops counting. Main timer is being cleared after writing of bit 2 in control register 0Ch via RS-485 interface. Clearing of totalizer occurs after bit 3 in control register 0Ch is set.

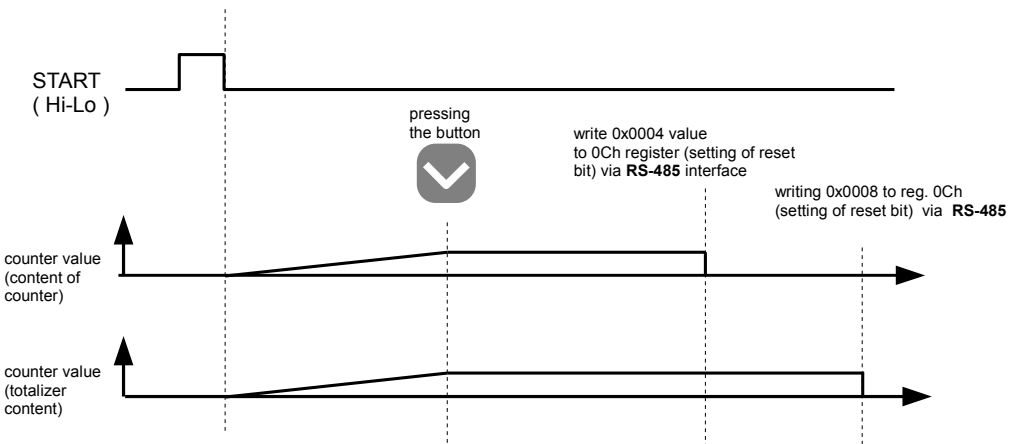

9. THE MODBUS PROTOCOL HANDLING

Transmission parameters: 1 start bit, 8 data bits, 1 stop bit, no parity control
 Baud rate: selectable from: 1200 to 115200 bits/second
 Transmission protocol: MODBUS RTU compatible

The device parameters and measurement result are available via RS-485 interface, as HOLDING-type registers of Modbus RTU protocol. The registers (or groups of the registers) can be read by 03h function, and wrote by 06h (single registers) or 10h (group of the registers) accordingly to Modbus RTU specification. Maximum group size for 03h and 10h functions can not exceeds 5 registers (for single frame).

The device interprets the broadcast messages, but then do not sends the answers.



Device also reads and processes BROADCAST queries, but then do not send any answers.

9.1. LIST OF REGISTERS

Register	Write	Range	Register description
01h	No	0 ÷ FFFFFFFF	Main timer value – higher word.
02h	No		Main timer value – lower word, combined value of registers 01h i 02h defines measured time expressed in seconds.
03h	No	0 ÷ 999	Main timer value - miliseconds
04h	No	0 ÷ 1	Counter state: 0 – counter stopped; 1 – counter is counting
05h	Yes	0 ÷ 4	“StArt” parameter (counting start mode) 0 - „Lo-Hi”, 1 - „Hi-Lo”, 2 - „Lo”, 3 - „Hi”
06h	Yes	0 ÷ 1	“StoP” parameter (counting stop mode) 0 - „Lo-Hi”, 1 - „Hi-Lo”
07h	Yes	0 ÷ 1	“rESEt” parameter (counter clearing mode) 0 - „Lo”, 1 - „Hi”
08h	Yes	0 ÷ 3	“C-diSP” parameter (main timer displaying format) 0 - „SEC”, 1 - „h-m-S”, 2 - „h-m”, 3 - „h-h10”
09h	Yes	0 ÷ 3	“C-PrEC” parameter (main timer displaying precision) 0 - „0.000”, 1 - „0.00 ”, 2 - „0.0 ”, 3 - „0. ”
0Ah	Yes	0 ÷ 2	“t-diSP” parameter (displaying format of totalizer) 0 - „h-m-S”, 1 - „h-m”, 2 - „h-h10”
0Bh	Yes	0 ÷ 1	“PuSH” parameter (enabling of control by local keyboard) 0 - „oFF”, 1 - „on”

Register	Write	Range	Register description
0Ch ¹	Yes	see descr.	Counter control. The control is realised by setting particular bits: bit 0 = „1” – counting start bit 1 = „1” – counting stop bit 2 = „1” – clearing of the main timer bit 3 = „1” – totalizer clearing. After executing of order, the value of this register is cleared automatically Bit 1 (stop) has higher priority than bit 0 (start), so entering of value 03h causes in counter stopping.
0Dh	No	0 ÷ FFFFFFFF	Totalizer value- higher word
0Eh	No		Totalizer value- lower word, joined value of registers 0Ch & 0Dh defined total seconds count
0Fh	No	0 ÷ 999	Totalizer value- milliseconds
10h	No	0 ÷ 3	Relays state in binary format (1 - closed, 0 - opened): 00 000 000 000 000 ba a - relay R1 b - relay R2
20h ²	Yes	0 ÷ 199	Device address
21h	No	007Bh	Device identification code (ID)
22h ³	Yes	0 ÷ 7	“ bAud ” parameter in “ rS-485 ” menu (baud rate); 0 - 1200 baud; 1 - 2400 baud; 2 - 4800 baud; 3 - 9600 baud; 4 - 19200 baud; 5 - 38400 baud; 6 - 57600 baud; 7 - 115200 baud
23h ⁴	Yes	0 ÷ 1	“ mbAccE ” parameter in “ rS-485 ” menu (permission to write registers via RS-485 interface); 0 - write denied ; 1 - write allowed
25h	Yes	0 ÷ 5	“ rESP ” parameter in “ rS-485 ” menu (additional response delay); 0 - no additional delay; 1 - “ 10c ” option; 2 - “ 20c ” option; 3 - “ 50c ” option; 4 - “ 100c ” option; 5 - “ 200c ” option;
2Dh	Yes	1 ÷ 8	“ briGHt ” parameter (display brightness); 1 - the lowest brightness; 8 - the highest brightness
2Fh	Yes	0 ÷ 1	“ Edit t ” parameter (numerical parameters edit mode); 0 - „ dig ” mode; 1 - „ SLid ” mode
30h	Yes	see descr.	Parameter “ Hr ” of “ rELAy1 ” / “ SEtP1 ” submenu (higher word).
31h	Yes	see descr.	Parameter “ Hr ” of “ rELAy1 ” / “ SEtP1 ” submenu (lower word). Joined value of registers 30h & 31h: from 0 to 99 999
32h	Yes	see descr.	Parameter “ min ” of “ rELAy1 ” submenu (higher word).
33h	Yes	see descr.	Parameter “ min ” w podmenu “ rELAy1 ” submenu (lower word). Joined value of registers 32h & 33h: from 0 to 999 999
34h	Yes	see descr.	Parameter “ SEC ” of “ rELAy1 ” submenu (higher word).
35h	Yes	see descr.	Parameter “ SEC ” of “ rELAy1 ” submenu (lower word). Joined value of registers 34h & 35h: from 0 to 999 999
36h	Yes	see descr.	Parameter “ mSEC ” of “ rELAy1 ” submenu (higher word).

Register	Write	Range	Register description
37h	Yes	see descr.	Parameter "mSEC" of "rELAY1" submenu (lower word). Joined value of registers 36h & 37h: from 0 to 999 999
38h	Yes	0 ÷ 2	Parameter "mode 1" of "rELAY1" (relay mode); 0 - tryb "noAct"; 1 - mode "on"; 2 - mode "oFF"; 3 - mode "modbuS"
39h	Yes	0 ÷ 1	Parameter "Src1" of "rELAY1": 0 -main timer; 1 - totalizer
40h	Yes	see descr.	Parameter "Hr" of "rELAY2" / "SEtP2" submenu (higher word).
41h	Yes	see descr.	Parameter "Hr" of "rELAY2" submenu (lower word). Joined value of registers 40h & 41h: from 0 to 99 999
42h	Yes	see descr.	Parameter "min" of "rELAY2" submenu (higher word).
43h	Yes	see descr.	Parameter "min" of "rELAY2" submenu (lower word). Joined value of registers 42h & 43h: from 0 to 999 999
44h	Yes	see descr.	Parameter "SEC" of "rELAY2" submenu (higher word).
45h	Yes	see descr.	Parameter "SEC" of "rELAY2" submenu (lower word). Joined value of registers 44h & 45h: from 0 to 999 999
46h	Yes	see descr.	Parameter "mSEC" of "rELAY2" submenu (higher word).
47h	Yes	see descr.	Parameter "mSEC" of "rELAY2" submenu (lower word). Joined value of registers 46h & 47h: from 0 to 999 999
48h	Yes	0 ÷ 2	Parameter "mode 2" of "rELAY2" (relay mode); 0 - tryb "noAct"; 1 - mode "on"; 2 - mode "oFF"; 3 - mode "modbuS"
49h	Yes	0 ÷ 1	Parameter "Src2" of "rELAY2": 0 -main timer; 1 - totalizer

- 1 - if parameter "StArt" is set to „Lo" or „Hi" start and stop may not be done using RS-485 interface
- 2 - after writing to register no 20h the device responds with an "old" address in the message.
- 3 - after writing to register no 22h the device responds with the new baud rate.
- 4 - the value of the "mbAccE" parameter is also connected to write to this register, so it is possible to block a writes, but impossible to unblock writes via RS-485 interface, The unblocking of the writes is possible from menu level only.



Starting, stopping, and clearing of the counter via serial interface is affected by delay errors, depends on transmission speed and parameter „rESP". Example minimum delay while „Baud" = 9.600 and "rESP" = std equals about 14ms. The delay can be calculated using formula:

$$t_{D \min} = 10\,000 \times \frac{13 + "rESP"}{"bAud"} \quad [\text{miliseconds}]$$

$t_{D \min}$ - minimum delay (for „rESP" = „Std" use „rESP" = 0.)

9.2. TRANSMISSION ERRORS DESCRIPTION

If an error occurs while write or read of single register, then the device sends an error code according to Modbus RTU specifications (example message no 7).

Error codes:

- 01h** - illegal function (only functions 03h and 06h are available),
- 02h** - illegal register address
- 03h** - illegal data value
- 08h** - no write permission (see: “**mbAccE**” parameter)

9.3. EXAMPLES OF QUERY/ANSWER FRAMES

Examples apply for device with address 1. All values are represent hexadecimal.

Field description:

- ADDR** Device address on Modbus network
- FUNC** Function code
- REG H,L** Starting address (address of first register to read/write, Hi and Lo byte)
- COUNT H,L** No. of registers to read/write (Hi and Lo byte)
- BYTE C** Data byte count in answer frame
- DATA H,L**Data byte (Hi and Lo byte)
- CRC L,H** CRC error check (Hi and Lo byte)

1. Read of ID code

ADDR	FUNC	REG H,L		COUNT H,L		CRC L,H	
01	03	00	21	00	01	D4	00

The answer:

ADDR	FUNC	BYTE C	DATA H,L		CRC L,H	
01	03	02	00	7B	F8	67

DATA - identification code (007Bh)

2. Change of the device address from 1 to 2 (write to reg. 20h)

ADDR	FUNC	REG H,L		DATA H,L		CRC L,H	
01	06	00	20	00	02	09	C1

DATA H - 0

DATA L - new device address (2)

The answer (the same as the message):

ADDR	FUNC	REG H,L		DATA H,L		CRC L,H	
01	06	00	20	00	02	09	C1

3. Reading of main timer (in seconds)

ADDR	FUNC	REG H,L		COUNT H,L		CRC L,H	
01	03	00	01	00	02	95	CB

The answer:

ADDR	FUNC	BYTE C	DATA H1,L1		DATA H2,L2		CRC L,H	
01	03	04	00	00	00	57	BB	CD

DATA - 00000057h = 87, displayed value = 87

4. Setting of format to „h-m-S” (hours.minutes.seconds.milliceconds).

ADDR	FUNC	REG H,L		DATA H,L		CRC L,H	
01	06	00	09	00	01	98	08

The answer (the same as the message):

ADDR	FUNC	REG H,L		DATA H,L		CRC L,H	
01	06	00	09	00	01	98	08

After such order the device will display value in the format:
hours.minutes.seconds.milliceconds

5. Start to count (using control register).

ADDR	FUNC	REG H,L		DATA H,L		CRC L,H	
01	06	00	0C	00	01	88	09

The answer (the same as the message):

ADDR	FUNC	REG H,L		DATA H,L		CRC L,H	
01	06	00	0C	00	01	88	09

After this order counter start counting from last value

6. Attempt to writing of improper value to the register

ADDR	FUNC	REG H,L		DATA H,L		CRC L,H	
01	06	00	0A	00	04	A8	0B

DATA L – written value, out of permissible range (here 00h lub 01h)

Answer of the device (with error code included 03h):

ADDR	FUNC	ERR	CRC L,H	
01	86	03	02	61



There is no full implementation of the Modbus Protocol in the device. The functions presented above are available only.

10. DEFAULT AND USER'S SETTINGS LIST

Parameter	Description	Default value	User's value	Desc. page
Parameters of control inputs				
StArt	Configuration of START input	Lo-Hi		20
StoP	Configuration of STOP input	Lo-Hi		20
rESEt	Configuration of RESET input	Lo-Hi		20
Parameters of format and precision ("diSP" menu)				
C-diSP	Main timer displaying format	SEc		20
C-PrEC	Precision of main timer displaying	0.000		21
t-diSP	Totalizer displaying format	h-m		21
Parameters of keyboard configuration				
PuSH	Enable / disable control of the counter with local keyboard	oFF		21
Parameters of relay R1 operation ("rEL1" menu)				
SEtP1	Relay1 threshold	0		19
modE1	Relay1 mode	noAct		19
Src1	Relay1 control source	curr		19
Parameters of relay R2 operation ("rEL2" menu)				
SEtP2	Relay2 threshold	0		19
modE2	Relay2 mode	noAct		19
Src2	Relay2 control source	curr		19
RS 485 interface configuration (menu "rS-485")				
Addr	Device address	0		22
bAud	Baud rate	9600		22
mbAccE	Blocking of access to the configuration registers	on		22
rESP	Additional delay of answer transmission	Std		22
Display parameters				
briGHt	Display brightness	bri6		22
Configuration of numerical parameters edition				
Edit t	Numerical parameters edit mode	dig		23

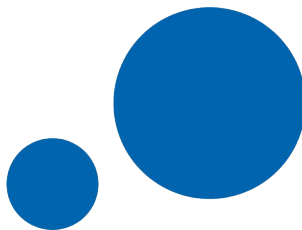

**SIMEX Sp. z o.o.
ul. Wielopole 7
80-556 Gdańsk
Poland**

**tel.: (+48 58) 762-07-77
fax: (+48 58) 762-07-70**

**<http://www.simex.pl>
e-mail: info@simex.pl**