

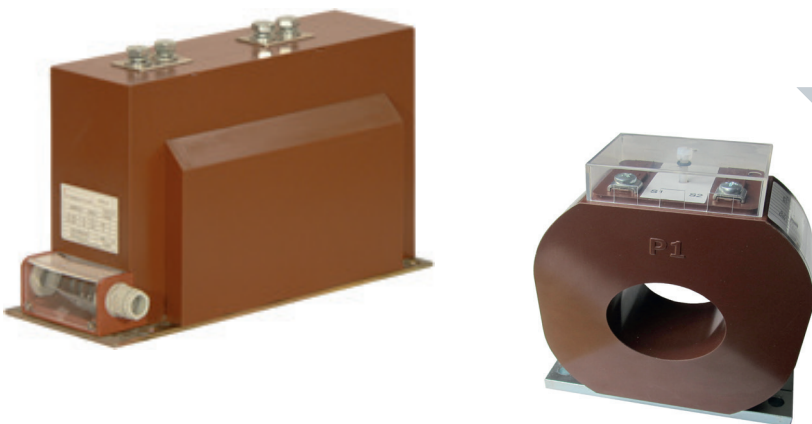

**MEDIUM VOLTAGE
TRANSFORMERS**



GMW – We make your values visible

We provide our customers with our products the entire spectrum to solve everything EMAS tasks and thus tools for sustainable use of electrical energy. As a complete provider we also realize the whole project from A to Z, from project consulting to commissioning, training and maintenance.

Medium-voltage current transformers

Medium-voltage voltage transformers

Low-voltage current transformers

Type Approval Certificate

This is to certify that the undenoted product(s) has/have been tested in accordance with the relevant requirements of the GL Type Approval System.

Certificate No.	12 282 - 98 HH
Company	Gilgen, Müller & Weigart (GMW) Kleinreuther Weg 88 90408 Nürnberg, GERMANY
Product Description	Panel Meters according to DIN 43 700
Type	DE 48, DE 72, DE 96, DG 48, DG 72, DG 96, DS 48, DS 72, DS 96, DGS 96E FM 48, FM 72, FM 96, LF 96, LM 96, LM 96-250
Environmental Category	C, EMC 1
Technical Data / Range of Application	Moving coil indicator, type: DS 48, ranges: 1mA to 25 A AC or 1 V to 600 V DS 72 / 96, ranges: 1mA to 50 A DC or 1 V to 6 Moving coil indicator with rectifier, type: DG 48 / 72 / 96, ranges: 1.2 A or 6 A AC, 60 V to Moving Iron Indicator, type: DE 48, ranges: 1 A to 25 A AC or 120 V to 600 DE 72 / 96, ranges: 1 A to 160 A AC or 120 V to FM 48 / 72 / 96, Fourtor frequency meter, Range Dgs 96 E, LM 96: power meter, for 2 to 4 cond. LM 96-250: power meter, for 2 to 4 conductor s LF 96: power factor meter, cap.0.5 - 1 - 0.5 ind. Class: 1.5 and 0.5 to 1.5 for pointer frequency Degree of protection: IP 52 (front), option: IP54 Casing: Polycarbonate UL 94 V0 Option: steel case (not Des 96 E, LM96, LM96- GL defines for the Performance of Type Approval Test report: BER-GL 00.DOC to SL 13.DOC; B Catalogue 2008 Analog Panel Meters Stand and sheet E1/28; Circ. diagram D18, D1W, E1B, E1 BNZ.233.391, 2-583-569-5
Test Standard	GL defines for the Performance of Type Approval
Documents	Test report: BER-GL 00.DOC to SL 13.DOC; B Catalogue 2008 Analog Panel Meters Stand and sheet E1/28; Circ. diagram D18, D1W, E1B, E1 BNZ.233.391, 2-583-569-5
Remarks	None
Valid until	2018-07-20
Page	1 of 1
File No.	LJ.04
Hamburg, 2013-06-21	

Germanischer Lloyd
This certificate is issued on the basis of the declaration for the Performance of Type Approval Part 1, Paragraph 2.



Certificate

Standard	ISO 9001:2008
Certificate Registr. No.	01 100 1300426

Certificate Holder:

**Gilgen, Müller & Weigart
(GMW), GmbH & Co. KG**
Am Farrnbach 4 a
D - 90556 Cadolzburg

including the locations according to annex

Scope: Design & Development, production, distribution and maintenance of measuring transducers and testing instruments as well as devices for the indications of electrical measured quantities

Proof has been furnished by means of an audit that the requirements of ISO 9001:2008 are met.

Validity: The certificate is valid from 2016-04-18 until 2018-09-14.
First certification 2004

2016-03-16

LGA Ing. Carl GmbH
111ystr. 2 - 90481 Nürnberg

www.lga-intercert.com

Contents

Technical characteristics		From page 4
Current transformers		Page 4
Voltage transformers		Page 8

Medium-voltage current transformers for indoor usage		From page 8
7.2 + 12 kV	Support-type current transformer; Narrow type according DIN 42600-8	Page 12
7.2 + 12 kV	Support-type current transformer; Elongated version (+ 55 mm)	Page 14
7.2 + 12 kV	Support-type current transformer; Elongated version (+ 135 mm)	Page 16
7.2 + 12 kV	Support-type current transformer; Narrow type according DIN 42600-8 with barriers	Page 18
7.2 + 12 kV	Support-type current transformer; Elongated version (+ 55 mm) with barriers	Page 20
24 kV	Support-type current transformer; Narrow type according DIN 42600-8	Page 22
24 kV	Support-type current transformer; Narrow type according DIN 42600-8 with barriers	Page 24
36 kV	Support-type current transformer	Page 26

Medium-voltage voltage transformers for indoor usage		From page 28
7.2 + 12 kV	Voltage transformer; single-pole isolated; Narrow type according DIN 42600-9	Page 28
7.2 + 12 kV	Voltage transformer; double-pole isolated; Narrow type according DIN 42600-9	Page 30
24 kV	Voltage transformer; single-pole isolated; Narrow type according DIN 42600-9	Page 32
24 kV	Voltage transformer; double-pole isolated; Narrow type according DIN 42600-9	Page 34
36 kV	Voltage transformer; single-pole isolated	Seite 36

Low-voltage current transformers for the usage in the isolated area of MV switchgear		From page 38
0.72 + 1.2 kV	Split-core current transformer for indoor usage	Page 38
0.72 + 1.2 kV	Single-piece tube current transformer for indoor usage	Page 40
0.72 kV	Single-piece tube current transformer for indoor usage	Page 42

Checklist for medium voltage transformers	Page 45
---	---------

Current transformers – Technical characteristics

Current transformers are special transformers for the proportional transformation of high currents into directly measurable values. Their construction and physical operating principle enables a galvanic separation of the primary circuit from the measured circuit, thereby providing a protection for sequentially connected instruments in the event of a fault.

Primary nominal current	Value of the primary current, that characterises the current transformer and for which it is designed.
Secondary nominal current	Value of the secondary current, that characterises the current transformer and for which it is designed.
Actual transformation ratio	Is the ratio of the primary nominal current to the secondary nominal current. It is specified as an unbridged break on the rating plate.
Burden	The impedance of the secondary current is declared in ohms and power factor. The burden is usually expressed as the apparent power in volt-amperes, absorbed at a specified power factor and at the rated secondary current.
Rated burden	The value of the burden upon which the accurate requirements of this specification are based.
Rated power	The value of the apparent power (in [VA] at a specified power factor), which the current transformer is intended to supply to the secondary circuit and rated burden at the rated secondary current.
Nominal frequency	Value of the frequency, on which the calculation of the current transformer is based.
Accuracy class	The denotation for a current transformer whose measuring deviation remains below the prescribed operating condition.
Phase displacement error $[\Delta\phi]$	Signifies the phase shift of the primary current and the secondary current. The direction of the indicator is arranged in such a way, that with an optimum produced current transformer the phase displacement error is equal to zero. The phase displacement error is to be regarded as positive when the indicator of the secondary current is ahead compared to the indicator of the primary current. The phase displacement error is specified in minutes or hundredths of a radiant. Note: Strictly speaking this definition is only valid for sinus type currents.
Current error (Transmission error)	Is the percentage deviation of the nominal transmission multiplied by the secondary current from that of the primary current. The current error is calculated positively, should the actual value of the secondary current exceed the nominal value.

$$F_i [\%] = \frac{(K_n I_s - I_p) \times 100}{I_p}$$

F_i = Current error in %
 K_n = Rated measuring ratio
 I_p = Primary current in A (effective value)
 I_s = Secondary current in A (effective value)

Max. voltage for electrical equipment U_m	This denotes the highest constant permitted value for phase to phase voltage for which the current transformers isolation is rated.
---	---

Total measuring deviation

Is the effective value in stationary position, and the difference between:

- a) The momentary value of the primary current and
- b) The momentary value of the measuring transmission of the multiplied actual secondary current, whereby the positive indicators of the primary and secondary current correspond to the accord for the connection denotation.

The total measuring deviation F_g is generally rendered in the percentages of the effective value of the primary current, as per the following mathematical equation:

$$F_g = \frac{100}{I_p} \times \sqrt{\frac{1}{T} \times \int_0^T (K_n i_s - i_p)^2 dt}$$

K_n = Rated measuring transmission

I_p = Effective value of the primary current

i_p = Momentary value of the primary current

i_s = Momentary value of the secondary current

T = Duration of period

Rated limit current [I_{pl}]

Value of the lowest primary current where, by the secondary measuring burden, the total deviation of the current transformer for measuring purposes is equal to or greater than 10%.

Over-current rated limiting factor (FS)

Is the ratio of the limit rated current to the primary rated current.

Rated continuous thermal current [I_{cth}]

Is the primary current which allows the continuous operation of the current transformer. When using this current value, the temperature of the secondary wiring must not exceed the prescribed values mentioned in the actual technical norms. This value is in direct relation to the isolation material class.

Thermal rated short-time current [I_{th}]

This value indicates the effective value of the primary current which the current transformers can withstand with short circuited secondary winding. Other rated measuring values as 1s, e.g. 0.5s, 2s and 3s are acceptable. The thermal short time rated current I_{th} has to be stated for each current transformer.

Rated surge current [I_{dyn}]

Peak value of the primary current, whose electro-mechanical impact is resisted by the current transformer with short circuited secondary winding.

„Open circuit voltage“ of current transformers

Current transformers, which are not directly encumbered with a burden, have to be generally secondarily short circuited!

A secondary open current transformer operates like a loaded one with an almost infinitely high burden. The curve shape of the secondary current is extremely deformed and under certain conditions voltage surges occur up to several kilovolts, which can be harmful to human beings. The amount of the induced “loss motion” depends on the core cross-section and the number of secondary turns.

Earthing of secondary terminals

According to DIN VDE 0141 (01/2000), section 5.3.4, current- and voltage transformers have to be secondarily earthed, starting from $U_m = 3.6$ kV.

The design of the earthing connections are mandatory up from series 10N.

Capacitive divider

On customer's request our medium-voltage current transformers CTS12M11(U)-T and CTS24M32(U)-T can be equipped with a capacitive divider according to EN 61243-5.

For a simple display of the voltage the capacity C1 of the high-voltage isolation is available at an additional secondary terminal, called Ck.

The capacitive voltage tap is designed for the HR-system.

When ordering current transformers with capacitive divider, it is required to mention the actual operating voltage UN (Rated voltage),

f.e. $U_m = 24$ kV, $U_N = 20$ kV.

Error limits for measuring transformers for classes 0.2...3 according to DIN EN 61869, part 2

At rated frequency and burden between 25 % and 100 % of the rated burden (at cl.3 between 50 % and 100 %) the maximum current error and the phase displacement error (at cl.3, there are no limits for the phase displacement error) may not exceed the values mentioned in the table below.

For all classes the burden need to have a power factor of 0.8 inductive and a minimum value of 1 VA, except the burden is lower than 5VA, then a power factor of 1.0 must be used.

Accuracy class	Current error $\pm \Delta I_F$ by					Phase displacement error $\pm \Delta \varphi_F$ by				
	1.2 I_n 1.0 I_n	0.5 I_n	0.2 I_n	0.05 I_n	0.01 I_n	1.2 I_n 1.0 I_n	0.5 I_n	0.2 I_n	0.05 I_n	0.01 I_n
	$\pm \%$	$\pm \%$	$\pm \%$	$\pm \%$	$\pm \%$	$\pm \text{min}$	$\pm \text{min}$	$\pm \text{min}$	$\pm \text{min}$	$\pm \text{min}$
0.2S	0.2		0.2	0.35	0.75	10		10	15	30
0.2	0.2		0.35	0.75		10		15	30	
0.5S	0.5		0.5	0.75	1.5	30		30	45	90
0.5	0.5		0.75	1.5		30		45	90	
1	1		1.5	3		60		90	180	
3	3	3								

Error limit values for current transformers for protection applications

At rated frequency and at rated burden the current error, the phase displacement error and the total measuring deviation may not exceed the values mentioned in the table below.

For all classes the burden need to have a power factor of 0.8 inductive and a minimum value of 1 VA, except the burden is lower than 5VA, then a power factor of 1.0 must be used.

Accuracy class	Current error $\pm F_i$ by		Phase displacement error $\pm F_i$ by	
	1.0 I_n and thermal nominal continuous current		1.0 I_n and thermal nominal continuous current	
	$\%$		min	
5 P ...	1		60	
10 P ...	3			

Current error F_g at nominal error current limit and nominal burden

Class 5P ... $\leq 5 \%$

Class 10P ... $\leq 10 \%$

Partial discharges

Partial discharge requirements are valid for instrument transformers with $U_m \geq 7.2 \text{ kV}$.

Partial discharge test voltages and permissible levels

Type of system earthing	Partial discharge test voltage (Effective value) kV	Permissible partial discharge level ²⁾ pC	
		Type of insulation	
		liquid insulation	solid insulation
Star point grounded ¹⁾ (Earth fault ≤ 1.5)	U_m $1.2 U_m / \sqrt{3}$	10 5	50 20
Star point isolated or not effectively grounded ¹⁾ (Earth fault > 1.5)	$1.2 U_m$ $1.2 U_m / \sqrt{3}$	10 5	50 20

1) If the type of system earthing is not mentioned, the values for the isolated or not effectively grounded star point are has to be taken.

2) The permissible partial discharge levels are also applicable for frequencies deviating from the nominal rated frequency.

Markings of the current transformers connection terminals

The connections of all primary windings are marked with capital letters „P1“ and „P2“. The connections of all secondary windings are marked with the corresponding lower case letters „s1“ and „s2“.

Power requirements of measuring setups

Two main requirements are cited by the user for the principle demands of current transformers:

- a high degree of measuring precision in the range of the nominal current
- a protection function in the over-load range

In order to fulfil these demands it is necessary for the assumed nominal power of a current transformer to fully achieve the actual power requirements of the prescribed measurements.

In ascertaining the actual power requirements, consideration is to be given to the power losses of the appliances to be connected, as well as to the losses of the measuring conductor.

The actual power consumption of the connected devices can be found in the respective data sheets.

Please note: If the power requirement of the measuring setup is substantially less than the power supply of the current transformer, the CT loses his protective function in over-current ranges. In some cases this can lead to a damage of the connected devices.

Power consumption of copper wires

$$P_v = \frac{I_s^2 \times 2 \times l}{A_{cu} \times 56} \text{ VA}$$

I_s = Secondary nominal current [A]
 l = Distance in m
 A_{cu} = Wire cross section in mm²
 P_v = Power loss of the measuring conductor

Comment: With a joint three phase current return conductor the values of P_v are halved.

Chart for values referring to 5 A

Nominal cross section	1 m	2 m	3 m	4 m	5 m	6 m	7 m	8 m	9 m	10 m
2.5 mm ²	0.36	0.71	1.07	1.43	1.78	2.14	2.50	2.86	3.21	3.57
4.0 mm ²	0.22	0.45	0.67	0.89	1.12	1.34	1.56	1.79	2.01	2.24
6.0 mm ²	0.15	0.30	0.45	0.60	0.74	0.89	1.04	1.19	1.34	1.49
10.0 mm ²	0.09	0.18	0.27	0.36	0.44	0.54	0.63	0.71	0.80	0.89

Chart for values referring to 1 A

Nominal cross section	10 m	20 m	30 m	40 m	50 m	60 m	70 m	80 m	90 m	100 m
1.0 mm ²	0.36	0.71	1.07	1.43	1.78	2.14	2.50	2.86	3.21	3.57
2.5 mm ²	0.14	0.29	0.43	0.57	0.72	0.86	1.00	1.14	1.29	1.43
4.0 mm ²	0.09	0.18	0.27	0.36	0.45	0.54	0.63	0.71	0.80	0.89
6.0 mm ²	0.06	0.12	0.18	0.24	0.30	0.36	0.42	0.48	0.54	0.60
10.0 mm ²	0.04	0.07	0.11	0.14	0.18	0.21	0.25	0.29	0.32	0.36

Voltage transformers – Technical characteristics

Voltage transformers are special transformers for the proportional transformation of high primary voltages into directly measurable, smaller secondary voltages. Their construction and physical operating principle enables a galvanic separation of the primary circuit from the measured circuit, thereby providing a protection for sequentially connected instruments in the event of a fault.

Single-pole isolated voltage transformers	Single-phase voltage transformer for phase-to-ground voltage. One end of the primary winding is provided for direct earthing.
Double-pole isolated voltage transformers	Voltage transformers for phase-to-phase voltage, in which all parts of the primary winding, including the terminals are isolated against earth.
Winding for earth fault detection	Winding of a single-phase voltage transformer, which is provided in a set of three single-phase VTs for connection in the open delta, to <ul style="list-style-type: none"> a) create a residual voltage at earth fault conditions b) damp ferro-resonances
	Please note: When connecting in open delta the winding of only one voltage transformer may be connected to ground, because otherwise the VTs are short-circuited.
Primary + secondary rated voltage	Value of the primary and secondary voltage, which is mentioned on the rating plate of the voltage transformer, and on which its operating characteristic is based.
Actual transformation ratio	Is the ratio of the primary nominal voltage to the secondary nominal voltage. It is specified as an unbridged break on the rating plate.
Burden	The impedance of the secondary voltage is declared in ohms and power factor. The burden is usually expressed as the apparent power in volt-amperes, absorbed at a specified power factor and at the rated secondary voltage.
Rated burden	The value of the burden upon which the accurate requirements of this specification are based.
Rated power	The value of the apparent power (in [VA] at a specified power factor), which the voltage transformer is intended to supply to the secondary circuit and rated burden at the rated secondary voltage.
Nominal frequency	Value of the frequency, on which the calculation of the voltage transformer is based.
Accuracy class	The denotation for a voltage transformer whose measuring deviation remains below the prescribed operating condition.
Phase displacement error [Δφ]	Signifies the phase shift of the primary voltage and the secondary voltage. The direction of the indicator is arranged in such a way, that with an optimum produced voltage transformer the phase displacement error is equal to zero.
Voltage error (Transmission error)	Measurement error, caused by a voltage transformer, which are a result of the difference between the actual ratio of the voltage transformer and the rated ratio. The voltage error (in %) is calculated according to the following formula:

$$\varepsilon u [\%] = \frac{k_r \cdot U_s - U_p}{U_p} \cdot 100$$

εu = Voltage error in %
 k_r = Rated transformation ratio
 U_p = Actual primary voltage
 U_s = Actual secondary voltage, when U_p flows under measurement conditions

Highest voltage for equipment U_m

RMS (kV) of the highest phase-to-phase voltage for which a instrument transformer is dimensioned in terms of its isolation.

Rated voltage factor [F_V]

Multiplication factor to be applied to the primary rated voltage, to determine the highest voltage at which the voltage transformer has to correspond to the thermal requirements and the requirements of the measuring accuracy for a specified time period. Single-pole isolate voltage transformers have usually a rated voltage factor of $1.9 \cdot U_N / 8h$, all other voltage transformers have a rated voltage factor of $1.2 \cdot U_N /$ continuously.

Thermal power

Value of the apparent power at rated voltage, which can be loaded on the secondary winding, without exceeding the limits of overtemperature.

Operation of voltage transformers

Voltage transformers must not be short circuited on the secondary side!
The grounding terminal of the primary winding (N) has to be effectively earthed and must not be removed during operation.

Earthing of secondary terminals

According to DIN VDE 0141 (01/2000), section 5.3.4, current- and voltage transformers have to be secondarily earthed, starting from $U_m = 3.6$ kV. The design of the earthing connections are mandatory up from series 10N.

Error limits for voltage transformers for classes 0.2...3 according to DIN EN 61869, part 3

At rated frequency and burden between 25 % and 100 % of the rated burden and at a power factor of $\cos \beta = 0,8$ (inductive) the voltage error and the phase displacement error may not exceed the values mentioned in the table below for primary voltage between 80 % and 120 % of the rated primary voltage.

Accuracy class	Voltage error ϵ_v	Phase displacement error $\pm \Delta_F$ by
	$\pm \%$	\pm min
0.2	0.2	10
0.5	0.5	20
1	1.0	40
3	3.0	-

Error limit values for voltage transformers for protection applications

At rated frequency and burden between 25 % and 100 % of the rated burden and at a power factor of $\cos \beta = 0,8$ (inductive) the voltage error and the phase displacement error may not exceed the values mentioned in the table below for primary voltage of 5 % of the rated primary voltage and for rated primary voltage multiplied with the rated voltage factor.

At 2 % of the rated primary voltage the limits of the voltage error and of the phase displacement error are twice as high as mentioned in below table.

Accuracy class	Voltage error ϵ_v	Phase displacement error $\Delta \phi$
	$\pm \%$	\pm min
3P	3,0	120
6P	6,0	240

Partial discharges

Partial discharge requirements are valid for instrument transformers with $U_m \geq 7.2$ kV.

Partial discharge test voltages and permissible levels for voltage transformers

Type of system earthing	Type of voltage transformer	Partial discharge test voltage (effective value) kV	Permissible partial discharge level ²⁾ pC	
			Type of insulation	
			Liquid- or gas isolation	solid isolation
Star point grounded ¹⁾ (Earth fault ≤ 1.4)	single-pole isolated	U_m $1.2 U_m / \sqrt{3}$	10 5	50 20
Star point grounded ¹⁾ (Earth fault ≤ 1.4)	double-pole isolated	$1.2 U_m$	5	20
Star point isolated or not effectively grounded ¹⁾ (Earth fault > 1.4)	single-pole isolated	$1.2 U_m$ $1.2 U_m / \sqrt{3}$	10 5	50 20
Star point isolated or not effectively grounded ¹⁾ (Earth fault > 1.4)	double-pole isolated	$1.2 U_m$	5	20

- 1) If the type of system earthing is not mentioned, the values for the isolated or not effectively grounded star point are has to be taken.
- 2) The permissible partial discharge levels are also applicable for frequencies deviating from the nominal rated frequency.

Markings of the voltage transformers connection terminals

The connections of the primary windings are marked with capital letters „A“, „B“ and „N“. The connections of the secondary terminals are marked with the corresponding lower case letters „a“, „b“ and „n“.

The letters „A“ and „B“ indicate the fully isolated connections and the letter „N“ indicated the terminal, which is provided for earthing. The isolation of „N“ is lower than the isolation of the other connections.

The marking „da“ and „dn“ denotes the terminal of the winding for earth fault detection.



Support type current transformers for indoor application 7.2 kV and 12 kV – Narrow type according to DIN 42600, part 8



Description:

Medium-voltage current transformers for indoor application, which are converting multiple primary currents proportional and in-phase into measurable and standardized secondary currents.

These transformers are fully resin-hardened in polyurethane and are serving apart of their main function as a current transformer as well as a bus bar support.

These CTs are applicable both for measuring and protection purposes.

The medium-voltage current transformers are also available as multicore current transformers. The maximum quantity of cores depends on the chosen burden and accuracy class.

Optionally, the current transformers are available with primary or secondary reconnection.

At the primary reconnectable current transformers it is possible to choose between two primary nominal currents, depending if the connection is made in parallel or in series. The primary nominal currents can only be realized in ratio 1:2. At the secondary reconnectable current transformers the reconnection is realized by means of one or more secondary taps. Thereby the primary nominal current can be realized in various ratios.

Technical data:

	CTS12M11-T	CTS12M11U-T (primary reconnectable)	CTS12M11-T (secondary reconnectable)
Max. operating voltage U_m :	12 kV	12 kV	12 kV
Power frequency voltage:	28 kV	28 kV	28 kV
Lightning impulse voltage:	75 kV	75 kV	75 kV
Therm. nominal continuous rated current I_{cth} :	$1.2 \times I_N$	$1.2 \times I_N$	$1.2 \times I_N$
Therm. rated short-time current I_{th} :	$100 \times I_N$, 1 sec.; max. 40 kA, 1 sec.	$100 \times I_N$, 1 sec.; max. 40 kA, 1 sec.	$100 \times I_N$, 1 sec.; max. 40 kA, 1 sec.
Rated surge current I_{dyn} :	$2.5 \times I_{th}$	$2.5 \times I_{th}$	$2.5 \times I_{th}$
Primary nominal current:	5 A – 3000 A	2x5 A – 2x600 A	...-5 A – 3000-... A
Secondary nominal current:	5 A or 1 A	5 A or 1 A	5 A or 1 A
Nominal frequency:	50 / 60 Hz	50 / 60 Hz	50 / 60 Hz
Measuring CT accuracy classes:	1; 0.5; 0.5S; 0.2; 0.2S	1; 0.5; 0.5S; 0.2; 0.2S	1; 0.5; 0.5S; 0.2; 0.2S
Protection CT accuracy classes:	5P5; 5P10; 5P20; 5P30; 10P5; 10P10; 10P20; 10P30	5P5; 5P10; 5P20; 5P30; 10P5; 10P10; 10P20; 10P30	5P5; 5P10; 5P20; 5P30; 10P5; 10P10; 10P20; 10P30
Capacitive divider:	Available on request	Available on request	Available on request
Insulation class:	E	E	E
Cantilever strength:	5000 Nm	5000 Nm	5000 Nm
Weight:	approx. 22 kg	approx. 22 kg	approx. 22 kg

Subject to technical modifications without notice

Please note, that the above mentioned data are standard values. Other values on request.

Drawings:

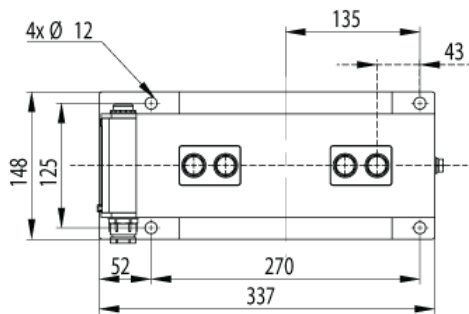
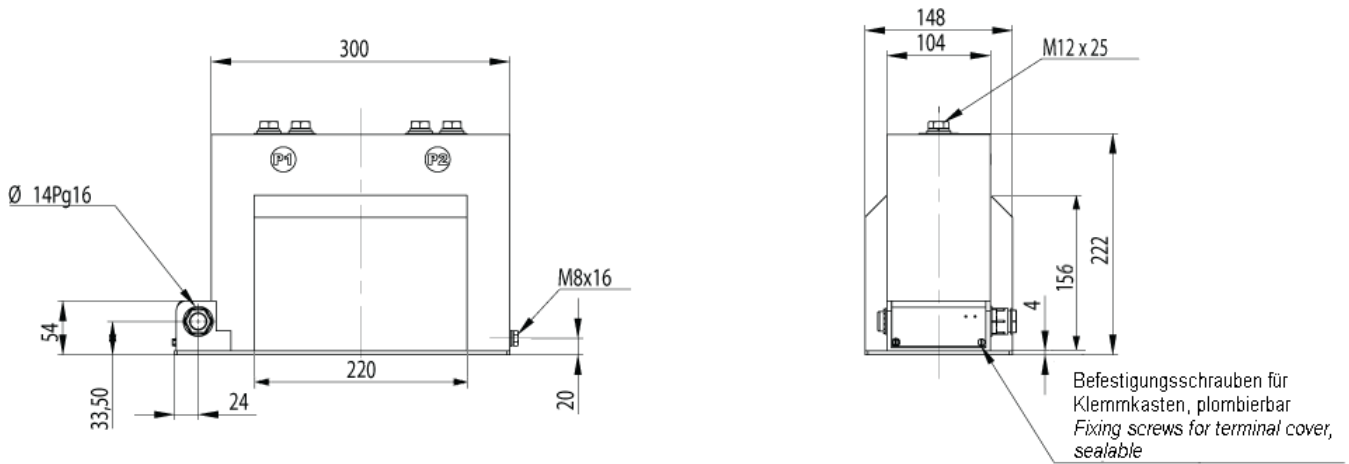

Primary connections:

up to 1250 A:

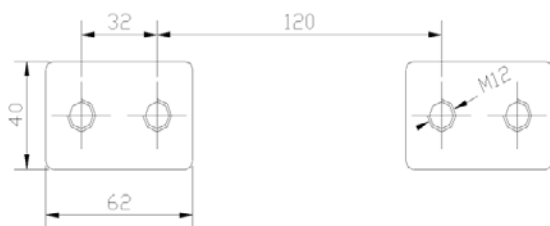

Primary reconnectable up to 1200 A:

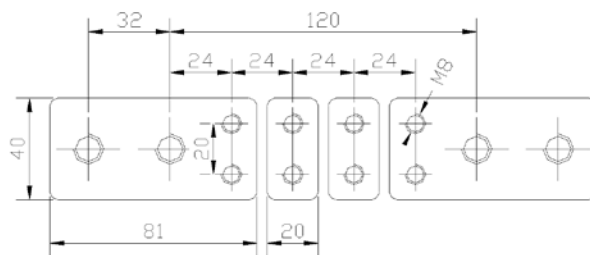

< 1250 A up to 3000 A:

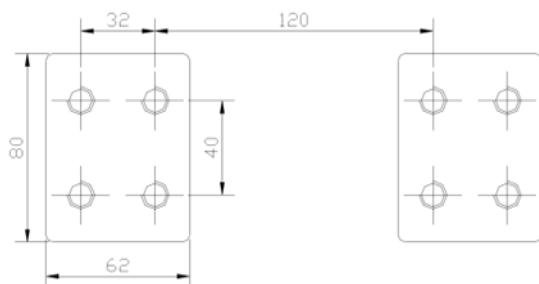

Terminal assignment – Primary reconnection:

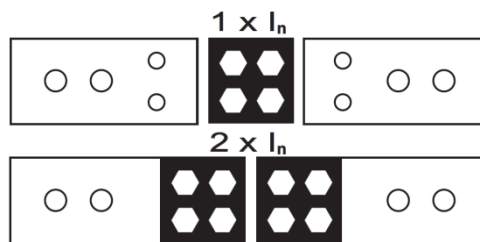

Support type current transformers for indoor application 7.2 kV and 12 kV – elongated by 55mm for increased demands



Description:

Medium-voltage current transformers for indoor application, which are converting multiple primary currents proportional and in-phase into measurable and standardized secondary currents.

These transformers are fully resin-hardened in polyurethane and are serving apart of their main function as a current transformer as well as a bus bar support.

These CTs are applicable both for measuring and protection purposes.

The medium-voltage current transformers are also available as multicore current transformers. The maximum quantity of cores depends on the chosen burden and accuracy class.

Optionally, the current transformers are available with primary or secondary reconnection.

At the primary reconnectable current transformers it is possible to choose between two primary nominal currents, depending if the connection is made in parallel or in series. The primary nominal currents can only be realized in ratio 1:2. At the secondary reconnectable current transformers the reconnection is realized by means of one or more secondary taps. Thereby the primary nominal current can be realized in various ratios.

Technical data:

	CTS12L11-T	CTS12L11U-T (primary reconnectable)	CTS12L11-T (secondary reconnectable)
Max. operating voltage U_m :	12 kV	12 kV	12 kV
Power frequency voltage:	28 kV	28 kV	28 kV
Lightning impulse voltage:	75 kV	75 kV	75 kV
Therm. nominal continuous rated current I_{cth} :	$1.2 \times I_N$	$1.2 \times I_N$	$1.2 \times I_N$
Therm. rated short-time current I_{th} :	$100 \times I_N$, 1 sec.; max. 40 kA, 1 sec.	$100 \times I_N$, 1 sec.; max. 40 kA, 1 sec.	$100 \times I_N$, 1 sec.; max. 40 kA, 1 sec.
Rated surge current I_{dyn} :	$2.5 \times I_{th}$	$2.5 \times I_{th}$	$2.5 \times I_{th}$
Primary nominal current:	5 A – 3000 A	2x5 A – 2x600 A	...-5 A – 3000-... A
Secondary nominal current:	5 A or 1 A	5 A or 1 A	5 A or 1 A
Nominal frequency:	50 / 60 Hz	50 / 60 Hz	50 / 60 Hz
Measuring CT accuracy classes:	1; 0.5; 0.5S; 0.2; 0.2S	1; 0.5; 0.5S; 0.2; 0.2S	1; 0.5; 0.5S; 0.2; 0.2S
Protection CT accuracy classes:	5P5; 5P10; 5P20; 5P30; 10P5; 10P10; 10P20; 10P30	5P5; 5P10; 5P20; 5P30; 10P5; 10P10; 10P20; 10P30	5P5; 5P10; 5P20; 5P30; 10P5; 10P10; 10P20; 10P30
Insulation class:	E	E	E
Cantilever strength:	5000 Nm	5000 Nm	5000 Nm
Weight:	approx. 35 kg	approx. 35 kg	approx. 35 kg

Subject to technical modifications without notice

Please note, that the above mentioned data are standard values. Other values on request.

Drawings:

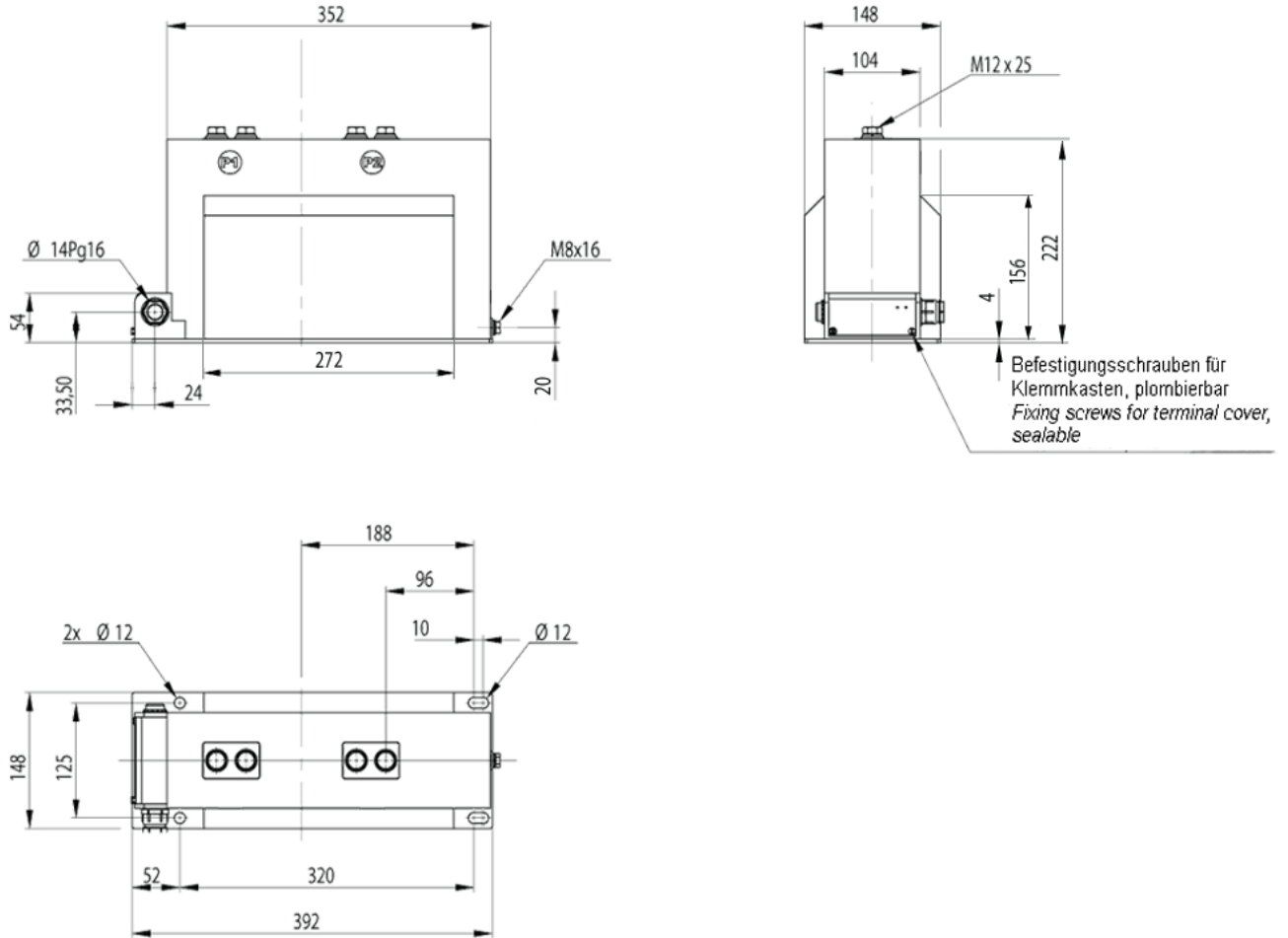

Primary connections:

up to 1250 A:

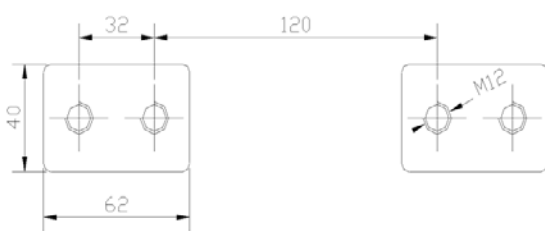

Primary reconnectable up to 1200 A:

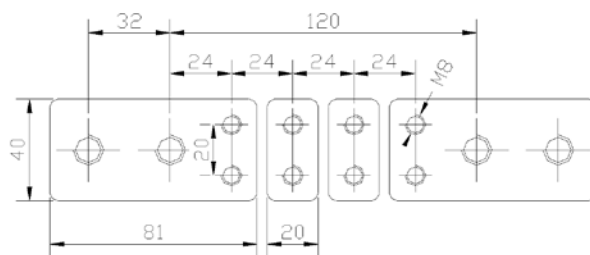

< 1250 A up to 3000 A:

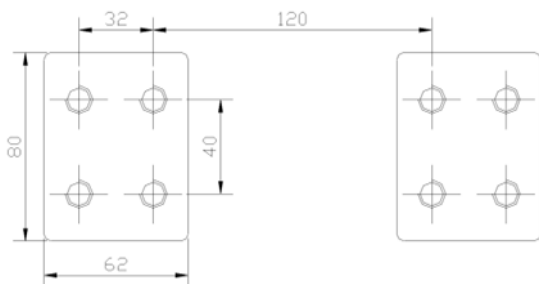

Terminal assignment – Primary reconnection:

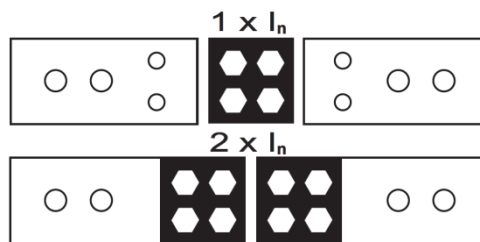

Support type current transformers for indoor application

7.2 kV and 12 kV – elongated by 135mm for increased demands and up to 6 measuring- or protection cores



Description:

Medium-voltage current transformers for indoor application, which are converting multiple primary currents proportional and in-phase into measurable and standardized secondary currents.

These transformers are fully resin-hardened in polyurethane and are serving apart of their main function as a current transformer as well as a bus bar support.

These CTs are applicable both for measuring and protection purposes.

The medium-voltage current transformers are also available as multicore current transformers. The maximum quantity of cores depends on the chosen burden and accuracy class.

Optionally, the current transformers are available with primary or secondary reconnection.

At the primary reconnectable current transformers it is possible to choose between two primary nominal currents, depending if the connection is made in parallel or in series. The primary nominal currents can only be realized in ratio 1:2. At the secondary reconnectable current transformers the reconnection is realized by means of one or more secondary taps. Thereby the primary nominal current can be realized in various ratios.

Technical data:

	CTS12XL11-T	CTS12XL11U-T (primary reconnectable)	CTS12XL11-T (secondary reconnectable)
Max. operating voltage U_m :	12 kV	12 kV	12 kV
Power frequency voltage:	28 kV	28 kV	28 kV
Lightning impulse voltage:	75 kV	75 kV	75 kV
Therm. nominal continuous rated current I_{cth} :	$1.2 \times I_N$	$1.2 \times I_N$	$1.2 \times I_N$
Therm. rated short-time current I_{th} :	$100 \times I_N$, 1 sec.; max. 40 kA, 1 sec.	$100 \times I_N$, 1 sec.; max. 40 kA, 1 sec.	$100 \times I_N$, 1 sec.; max. 40 kA, 1 sec.
Rated surge current I_{dyn} :	$2.5 \times I_{th}$	$2.5 \times I_{th}$	$2.5 \times I_{th}$
Primary nominal current:	5 A – 3000 A	2x5 A – 2x600 A	...-5 A – 3000-... A
Secondary nominal current:	5 A or 1 A	5 A or 1 A	5 A or 1 A
Nominal frequency:	50 / 60 Hz	50 / 60 Hz	50 / 60 Hz
Measuring CT accuracy classes:	1; 0.5; 0.5S; 0.2; 0.2S	1; 0.5; 0.5S; 0.2; 0.2S	1; 0.5; 0.5S; 0.2; 0.2S
Protection CT accuracy classes:	5P5; 5P10; 5P20; 5P30; 10P5; 10P10; 10P20; 10P30	5P5; 5P10; 5P20; 5P30; 10P5; 10P10; 10P20; 10P30	5P5; 5P10; 5P20; 5P30; 10P5; 10P10; 10P20; 10P30
Insulation class:	E	E	E
Cantilever strength:	5000 Nm	5000 Nm	5000 Nm
Weight:	approx. 45 kg	approx. 45 kg	approx. 45 kg

Subject to technical modifications without notice

Please note, that the above mentioned data are standard values. Other values on request.

Drawings:

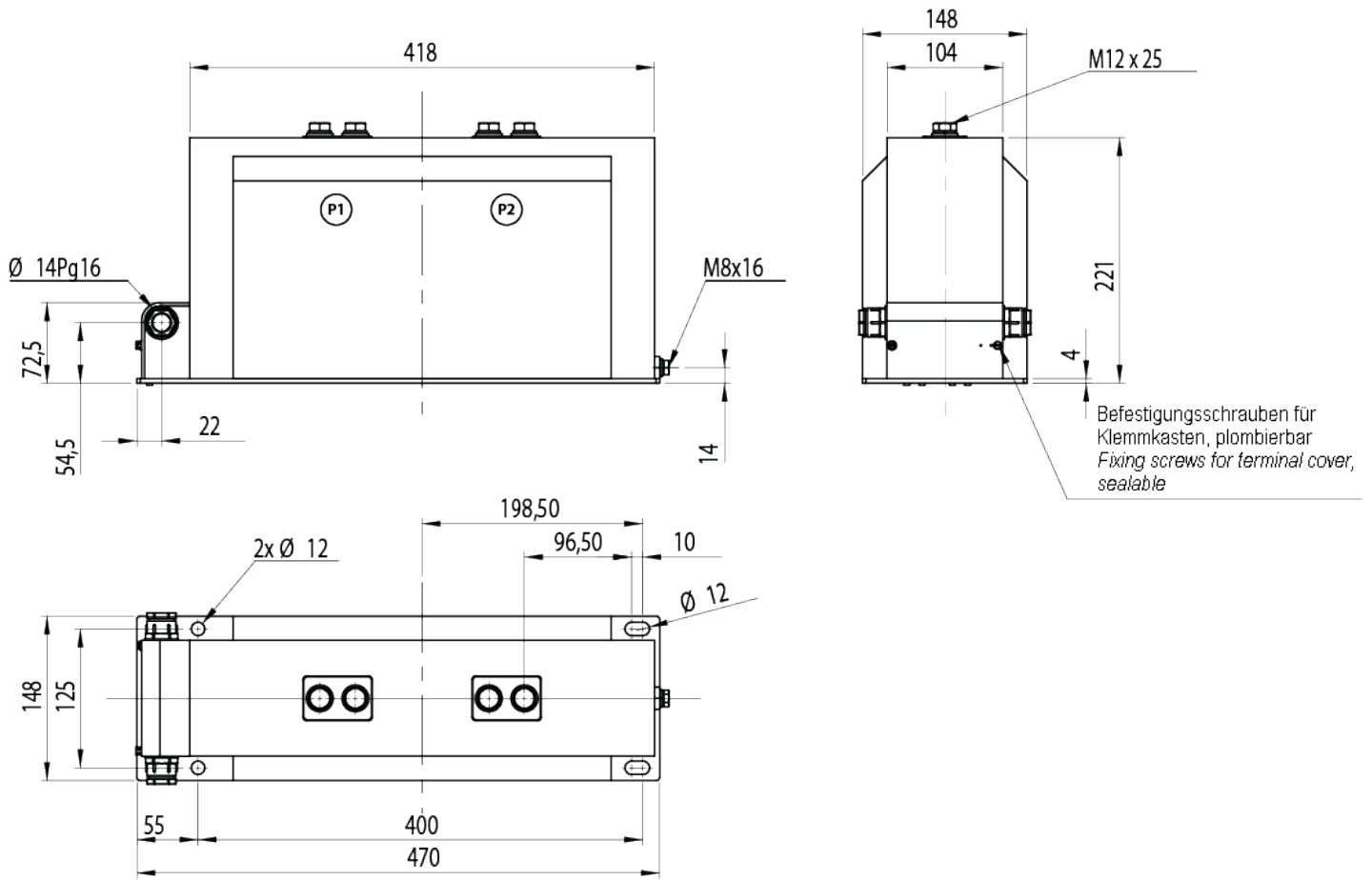

Primary connections:

up to 1250 A:

Primary reconnectable up to 1200 A:

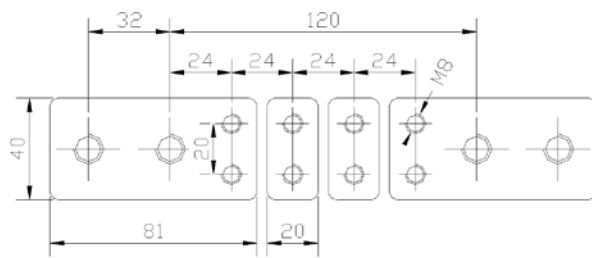
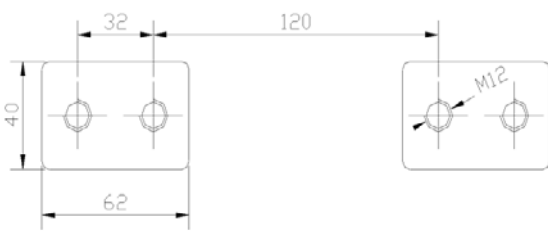

< 1250 A up to 3000 A:

Terminal assignment – Primary reconnection:

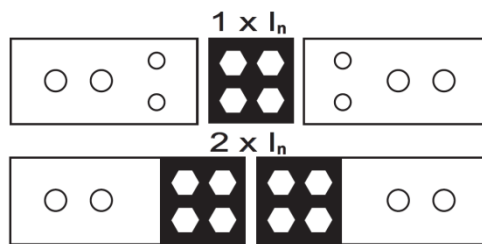
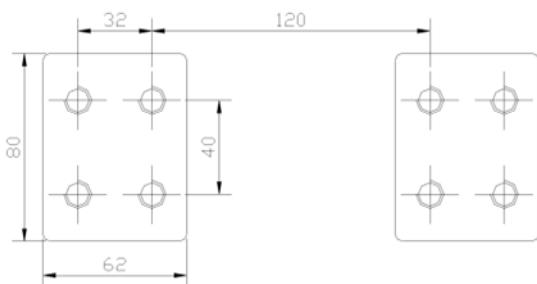

Support type current transformers for indoor application

7.2 kV and 12 kV – Narrow type according to DIN 42600, part 8 with barriers

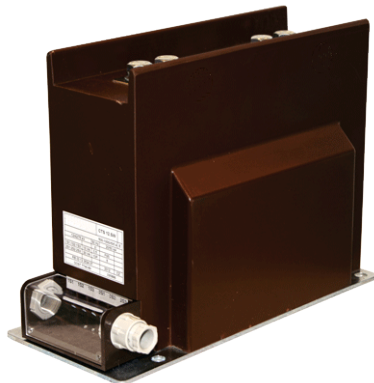

Description:

Medium-voltage current transformers for indoor application, which are converting multiple primary currents proportional and in-phase into measurable and standardized secondary currents.

These transformers are fully resin-hardened in polyurethane and are serving apart of their main function as a current transformer as well as a bus bar support.

These CTs are applicable both for measuring and protection purposes.

The medium-voltage current transformers are also available as multicore current transformers. The maximum quantity of cores depends on the chosen burden and accuracy class.

Optionally, the current transformers are available with primary or secondary reconnection.

At the primary reconnectable current transformers it is possible to choose between two primary nominal currents, depending if the connection is made in parallel or in series. The primary nominal currents can only be realized in ratio 1:2.

At the secondary reconnectable current transformers the reconnection is realized by means of one or more secondary taps. Thereby the primary nominal current can be realized in various ratios.

Technical data:

	CTS12M11B-T	CTS12M11BU-T (primary reconnectable)	CTS12M11B-T (secondary reconnectable)
Max. operating voltage U_m :	12 kV	12 kV	12 kV
Power frequency voltage:	28 kV	28 kV	28 kV
Lightning impulse voltage:	75 kV	75 kV	75 kV
Therm. nominal continuous rated current I_{cth} :	$1.2 \times I_N$	$1.2 \times I_N$	$1.2 \times I_N$
Therm. rated short-time current I_{th} :	$100 \times I_N$, 1 sec.; max. 40 kA, 1 sec.	$100 \times I_N$, 1 sec.; max. 40 kA, 1 sec.	$100 \times I_N$, 1 sec.; max. 40 kA, 1 sec.
Rated surge current I_{dyn} :	$2.5 \times I_{th}$	$2.5 \times I_{th}$	$2.5 \times I_{th}$
Primary nominal current:	5 A – 3000 A	2x5 A – 2x600 A	...-5 A – 3000-... A
Secondary nominal current:	5 A or 1 A	5 A or 1 A	5 A or 1 A
Nominal frequency:	50 / 60 Hz	50 / 60 Hz	50 / 60 Hz
Measuring CT accuracy classes:	1; 0.5; 0.5S; 0.2; 0.2S	1; 0.5; 0.5S; 0.2; 0.2S	1; 0.5; 0.5S; 0.2; 0.2S
Protection CT accuracy classes:	5P5; 5P10; 5P20; 5P30; 10P5; 10P10; 10P20; 10P30	5P5; 5P10; 5P20; 5P30; 10P5; 10P10; 10P20; 10P30	5P5; 5P10; 5P20; 5P30; 10P5; 10P10; 10P20; 10P30
Insulation class:	E	E	E
Cantilever strength:	5000 Nm	5000 Nm	5000 Nm
Weight:	approx. 23 kg	approx. 23 kg	approx. 23 kg

Subject to technical modifications without notice

Please note, that the above mentioned data are standard values. Other values on request.

Drawings:

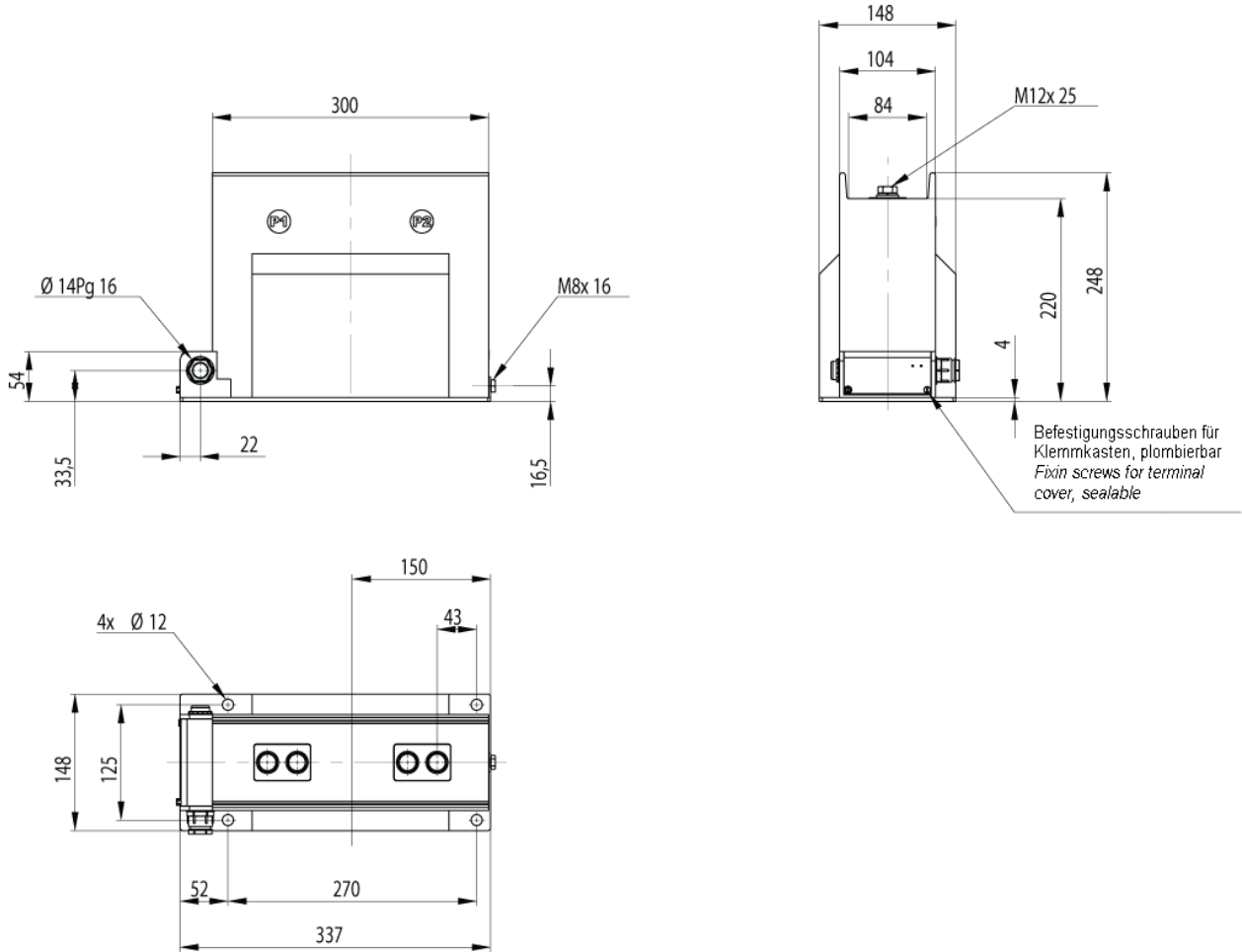

Primary connections:

up to 1250 A:

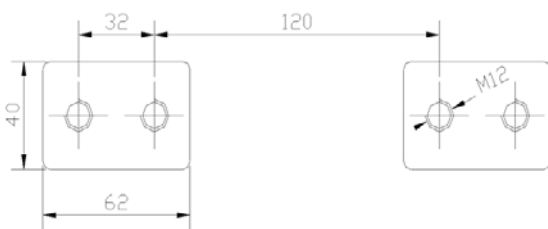

Primary reconnectable up to 1200 A:

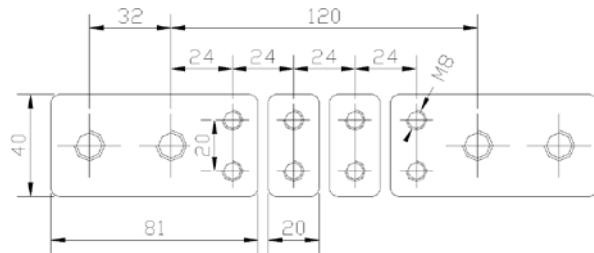

< 1250 A up to 3000 A:

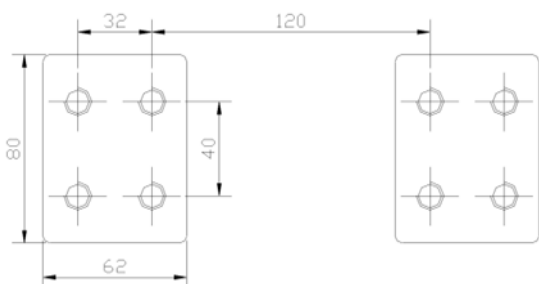

Terminal assignment – Primary reconnection:

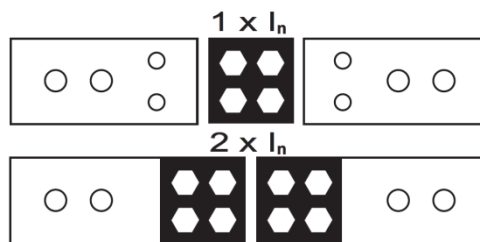

Support type current transformers for indoor application

7.2 kV and 12 kV – elongated by 55mm for increased demands with barriers

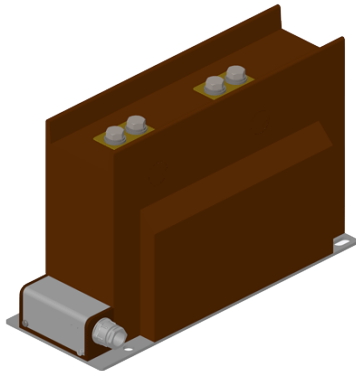

Description:

Medium-voltage current transformers for indoor application, which are converting multiple primary currents proportional and in-phase into measurable and standardized secondary currents.

These transformers are fully resin-hardened in polyurethane and are serving apart of their main function as a current transformer as well as a bus bar support.

These CTs are applicable both for measuring and protection purposes.

The medium-voltage current transformers are also available as multicore current transformers. The maximum quantity of cores depends on the chosen burden and accuracy class.

Optionally, the current transformers are available with primary or secondary reconnection.

At the primary reconnectable current transformers it is possible to choose between two primary nominal currents, depending if the connection is made in parallel or in series. The primary nominal currents can only be realized in ratio 1:2. At the secondary reconnectable current transformers the reconnection is realized by means of one or more secondary taps. Thereby the primary nominal current can be realized in various ratios.

Technical data:

	CTS12L11B-T	CTS12L11BU-T (primary reconnectable)	CTS12L11B-T (secondary reconnectable)
Max. operating voltage U_m :	12 kV	12 kV	12 kV
Power frequency voltage:	28 kV	28 kV	28 kV
Lightning impulse voltage:	75 kV	75 kV	75 kV
Therm. nominal continuous rated current I_{cth} :	$1.2 \times I_N$	$1.2 \times I_N$	$1.2 \times I_N$
Therm. rated short-time current I_{th} :	$100 \times I_N$, 1 sec.; max. 40 kA, 1 sec.	$100 \times I_N$, 1 sec.; max. 40 kA, 1 sec.	$100 \times I_N$, 1 sec.; max. 40 kA, 1 sec.
Rated surge current I_{dyn} :	$2.5 \times I_{th}$	$2.5 \times I_{th}$	$2.5 \times I_{th}$
Primary nominal current:	5 A – 3000 A	2x5 A – 2x600 A	...-5 A – 3000-... A
Secondary nominal current:	5 A or 1 A	5 A or 1 A	5 A or 1 A
Nominal frequency:	50 / 60 Hz	50 / 60 Hz	50 / 60 Hz
Measuring CT accuracy classes:	1; 0.5; 0.5S; 0.2; 0.2S	1; 0.5; 0.5S; 0.2; 0.2S	1; 0.5; 0.5S; 0.2; 0.2S
Protection CT accuracy classes:	5P5; 5P10; 5P20; 5P30; 10P5; 10P10; 10P20; 10P30	5P5; 5P10; 5P20; 5P30; 10P5; 10P10; 10P20; 10P30	5P5; 5P10; 5P20; 5P30; 10P5; 10P10; 10P20; 10P30
Insulation class:	E	E	E
Cantilever strength:	5000 Nm	5000 Nm	5000 Nm
Weight:	approx. 36 kg	approx. 36 kg	approx. 36 kg

Subject to technical modifications without notice

Please note, that the above mentioned data are standard values. Other values on request.

Drawings:

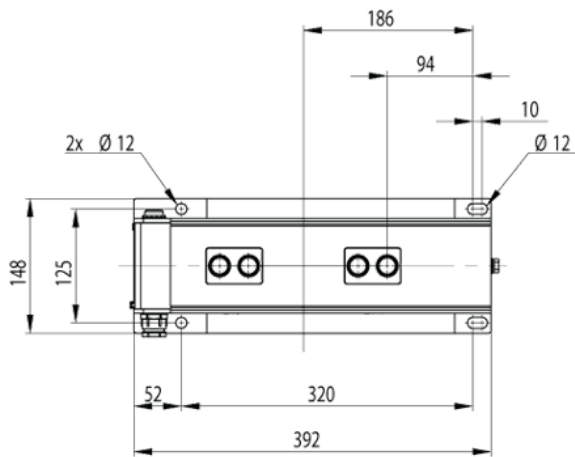
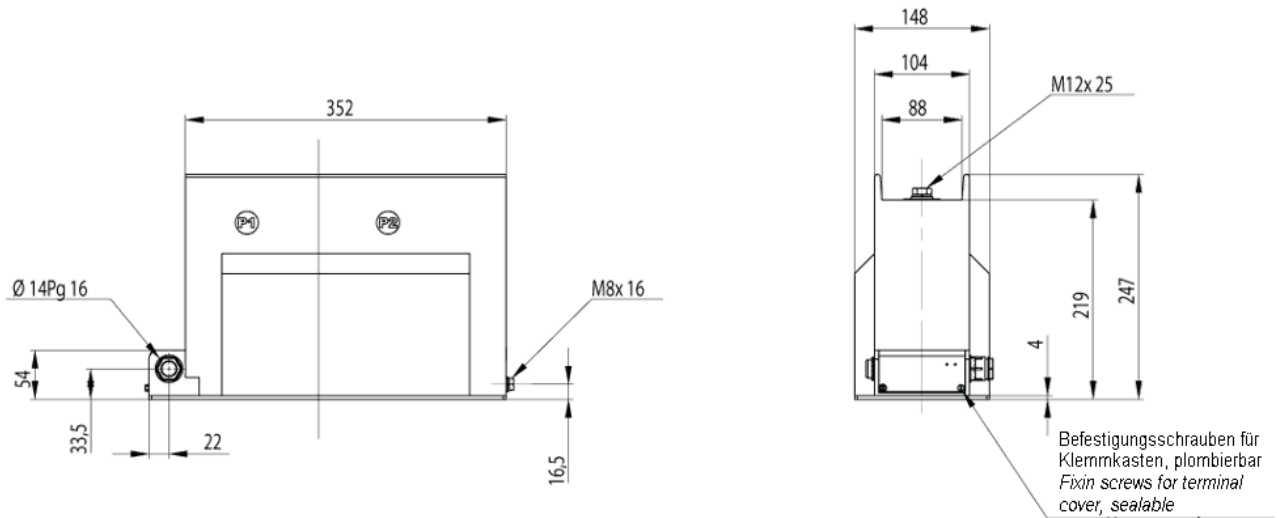

Primary connections:

up to 1250 A:

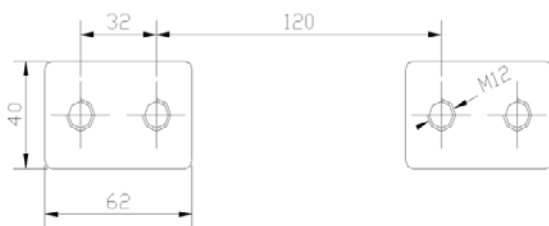

Primary reconnectable up to 1200 A:

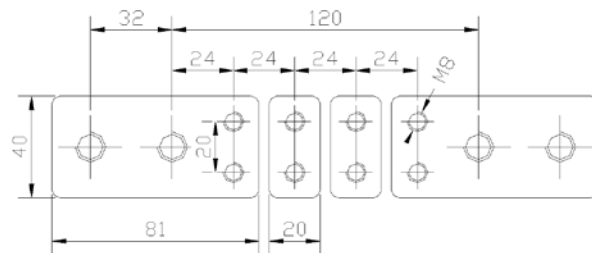

< 1250 A up to 3000 A:

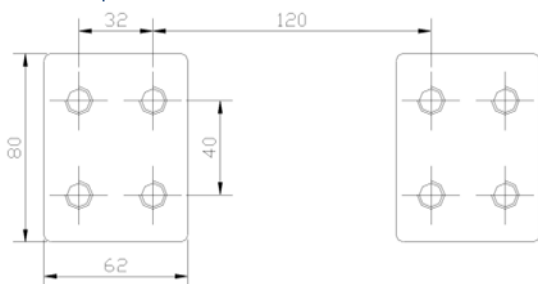

Terminal assignment – Primary reconnection:

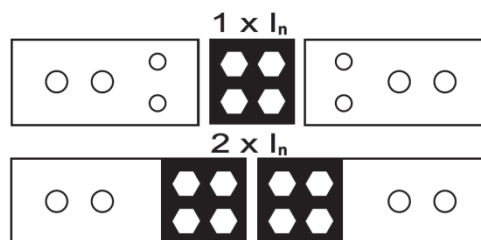

Support type current transformers for indoor application

24 kV – Narrow type according to DIN 42600, part 8



Description:

Medium-voltage current transformers for indoor application, which are converting multiple primary currents proportional and in-phase into measurable and standardized secondary currents.

These transformers are fully resin-hardened in polyurethane and are serving apart of their main function as a current transformer as well as a bus bar support.

These CTs are applicable both for measuring and protection purposes.

The medium-voltage current transformers are also available as multicore current transformers. The maximum quantity of cores depends on the chosen burden and accuracy class.

Optionally, the current transformers are available with primary or secondary reconnection.

At the primary reconnectable current transformers it is possible to choose between two primary nominal currents, depending if the connection is made in parallel or in series. The primary nominal currents can only be realized in ratio 1:2.

At the secondary reconnectable current transformers the reconnection is realized by means of one or more secondary taps. Thereby the primary nominal current can be realized in various ratios.

Technical data:

	CTS24M32-T	CTS24M32U-T (primary reconnectable)	CTS12M11-T (secondary reconnectable)
Max. operating voltage U_m :	24 kV	24 kV	24 kV
Power frequency voltage:	50 kV	50 kV	50 kV
Lightning impulse voltage:	125 kV	125 kV	125 kV
Therm. nominal continuous rated current I_{cth} :	$1.2 \times I_N$	$1.2 \times I_N$	$1.2 \times I_N$
Therm. rated short-time current I_{th} :	$100 \times I_N$, 1 sec.; max. 40 kA, 1 sec.	$100 \times I_N$, 1 sec.; max. 40 kA, 1 sec.	$100 \times I_N$, 1 sec.; max. 40 kA, 1 sec.
Rated surge current I_{dyn} :	$2.5 \times I_{th}$	$2.5 \times I_{th}$	$2.5 \times I_{th}$
Primary nominal current:	5 A – 1600 A	2x5 A – 2x600 A	...-5 A – 1600-... A
Secondary nominal current:	5 A or 1 A	5 A or 1 A	5 A or 1 A
Nominal frequency:	50 / 60 Hz	50 / 60 Hz	50 / 60 Hz
Measuring CT accuracy classes:	1; 0.5; 0.5S; 0.2; 0.2S	1; 0.5; 0.5S; 0.2; 0.2S	1; 0.5; 0.5S; 0.2; 0.2S
Protection CT accuracy classes:	5P5; 5P10; 5P20; 5P30; 10P5; 10P10; 10P20; 10P30	5P5; 5P10; 5P20; 5P30; 10P5; 10P10; 10P20; 10P30	5P5; 5P10; 5P20; 5P30; 10P5; 10P10; 10P20; 10P30
Capacitive divider:	Available on request	Available on request	Available on request
Insulation class:	E	E	E
Cantilever strength:	5000 Nm	5000 Nm	5000 Nm
Weight:	approx. 28 kg	approx. 28 kg	approx. 28 kg

Subject to technical modifications without notice

Please note, that the above mentioned data are standard values. Other values on request.

Drawings:

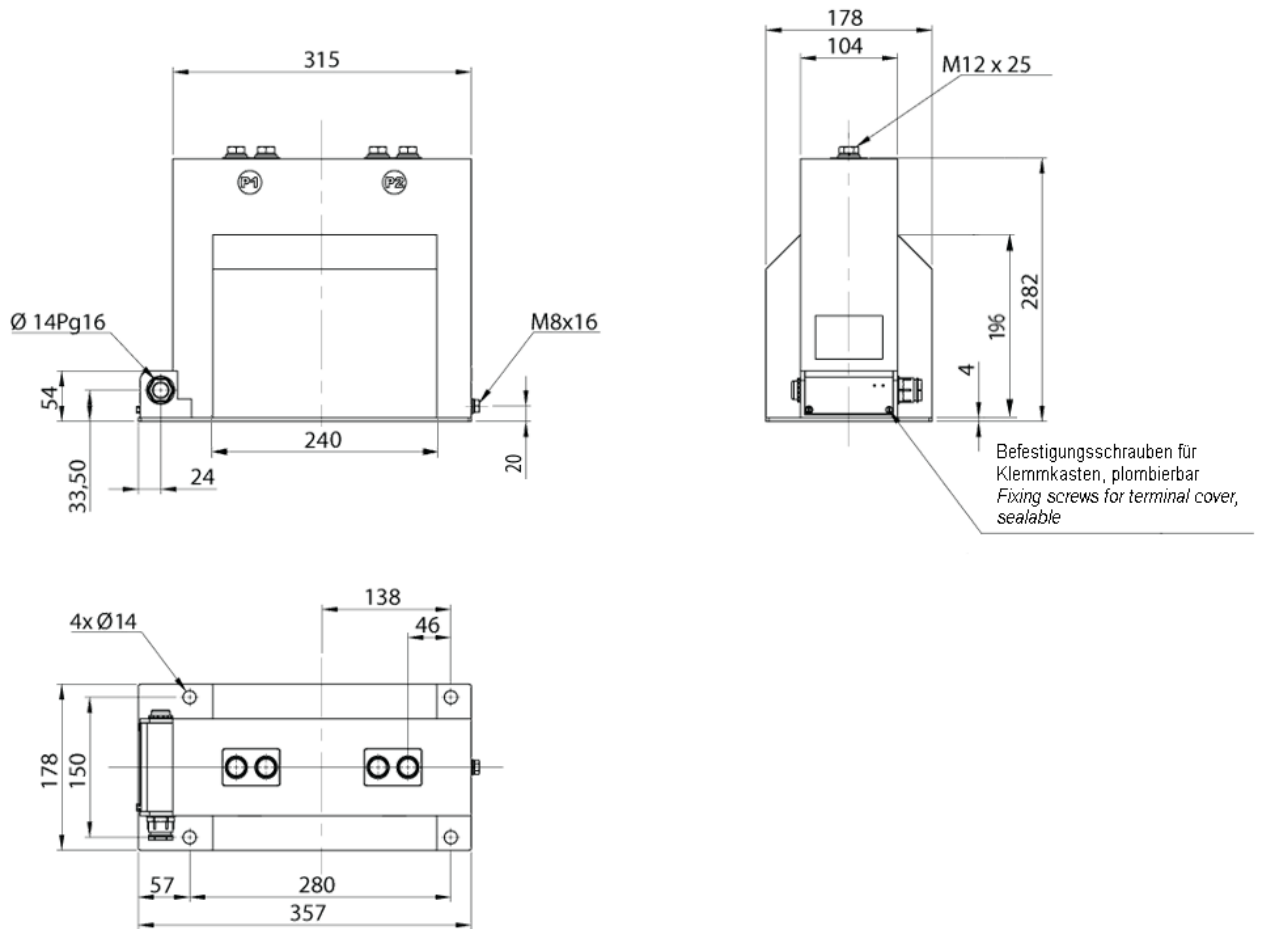

Primary connections:

up to 1250 A:

Primary reconnectable up to 1200 A:

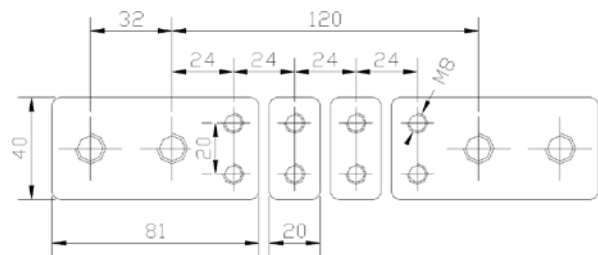
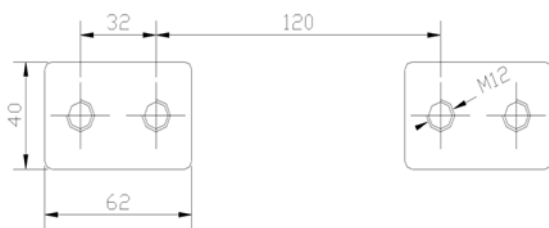

< 1250 A up to 3000 A:

Terminal assignment – Primary reconnection:

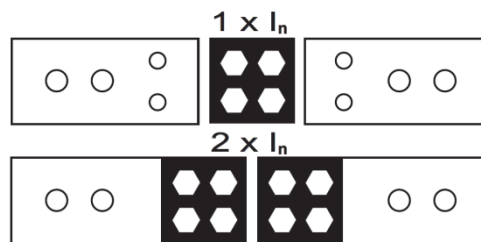
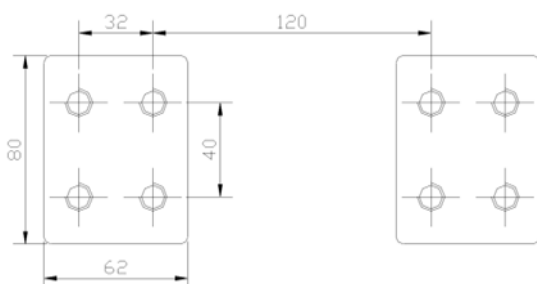

Support type current transformers for indoor application

24 kV – Narrow type according to DIN 42600, part 8 with barriers

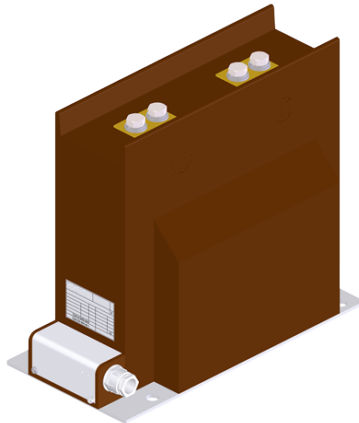

Description:

Medium-voltage current transformers for indoor application, which are converting multiple primary currents proportional and in-phase into measurable and standardized secondary currents.

These transformers are fully resin-hardened in polyurethane and are serving apart of their main function as a current transformer as well as a bus bar support.

These CTs are applicable both for measuring and protection purposes.

The medium-voltage current transformers are also available as multicore current transformers. The maximum quantity of cores depends on the chosen burden and accuracy class.

Optionally, the current transformers are available with primary or secondary reconnection.

At the primary reconnectable current transformers it is possible to choose between two primary nominal currents, depending if the connection is made in parallel or in series. The primary nominal currents can only be realized in ratio 1:2.

At the secondary reconnectable current transformers the reconnection is realized by means of one or more secondary taps. Thereby the primary nominal current can be realized in various ratios.

Technical data:

	CTS24M32B-T	CTS24M32BU-T (primary reconnectable)	CTS12M11B-T (secondary reconnectable)
Max. operating voltage U_m :	24 kV	24 kV	24 kV
Power frequency voltage:	50 kV	50 kV	50 kV
Lightning impulse voltage:	125 kV	125 kV	125 kV
Therm. nominal continuous rated current I_{cth} :	$1.2 \times I_N$	$1.2 \times I_N$	$1.2 \times I_N$
Therm. rated short-time current I_{th} :	$100 \times I_N$, 1 sec.; max. 40 kA, 1 sec.	$100 \times I_N$, 1 sec.; max. 40 kA, 1 sec.	$100 \times I_N$, 1 sec.; max. 40 kA, 1 sec.
Rated surge current I_{dyn} :	$2.5 \times I_{th}$	$2.5 \times I_{th}$	$2.5 \times I_{th}$
Primary nominal current:	5 A – 1600 A	2x5 A – 2x600 A	...-5 A – 1600-... A
Secondary nominal current:	5 A or 1 A	5 A or 1 A	5 A or 1 A
Nominal frequency:	50 / 60 Hz	50 / 60 Hz	50 / 60 Hz
Measuring CT accuracy classes:	1; 0.5; 0.5S; 0.2; 0.2S	1; 0.5; 0.5S; 0.2; 0.2S	1; 0.5; 0.5S; 0.2; 0.2S
Protection CT accuracy classes:	5P5; 5P10; 5P20; 5P30; 10P5; 10P10; 10P20; 10P30	5P5; 5P10; 5P20; 5P30; 10P5; 10P10; 10P20; 10P30	5P5; 5P10; 5P20; 5P30; 10P5; 10P10; 10P20; 10P30
Insulation class:	E	E	E
Cantilever strength:	5000 Nm	5000 Nm	5000 Nm
Weight:	approx. 29 kg	approx. 29 kg	approx. 29 kg

Subject to technical modifications without notice

Please note, that the above mentioned data are standard values. Other values on request.

Drawings:

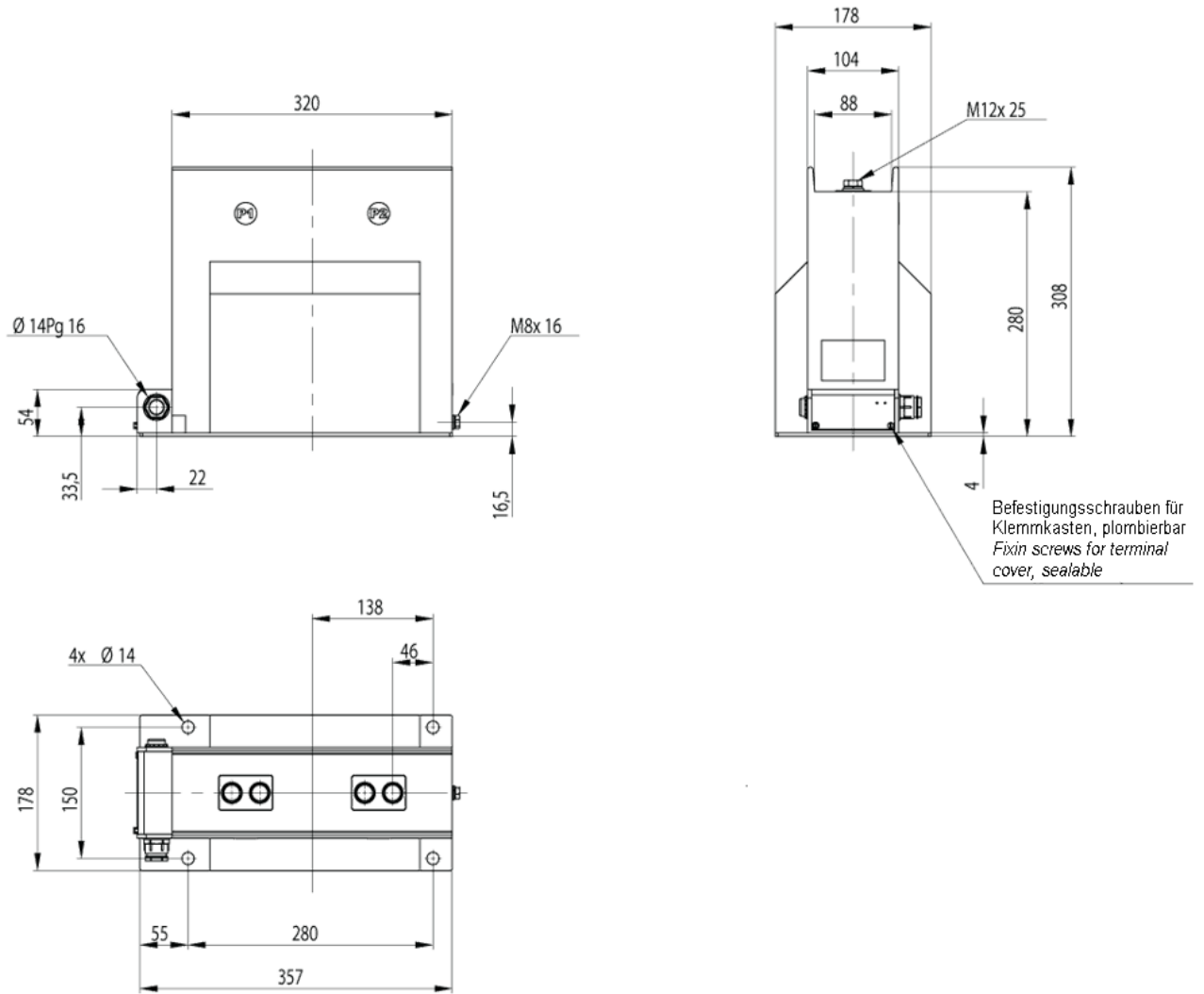

Primary connections:

up to 1250 A:

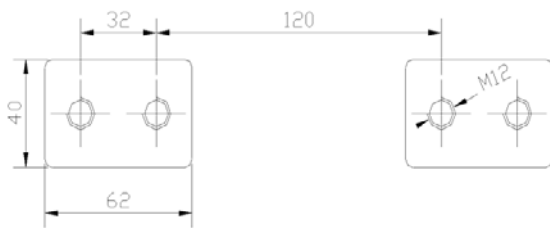

Primary reconnectable up to 1200 A:

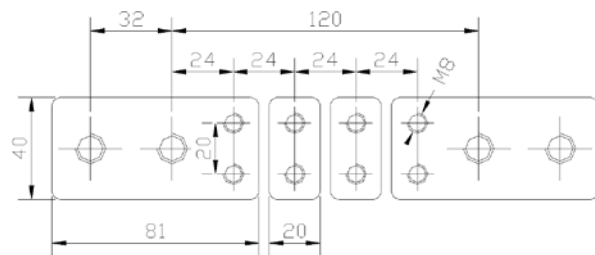

< 1250 A up to 3000 A:

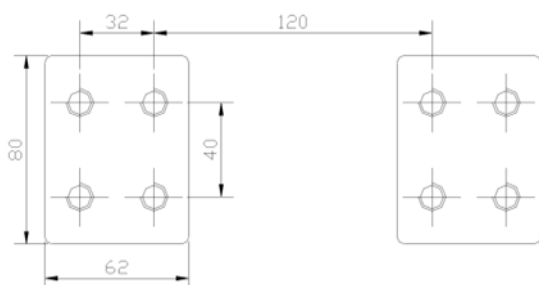

Terminal assignment – Primary reconnection:

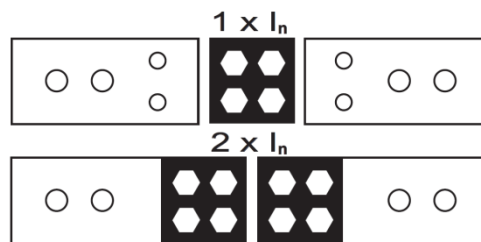

Support type current transformers for indoor application

36 kV



Description:

Medium-voltage current transformers for indoor application, which are converting multiple primary currents proportional and in-phase into measurable and standardized secondary currents.

These transformers are fully resin-hardened in polyurethane and are serving apart of their main function as a current transformer as well as a bus bar support.

These CTs are applicable both for measuring and protection purposes.

The medium-voltage current transformers are also available as multicore current transformers. The maximum quantity of cores depends on the chosen burden and accuracy class.

Optionally, the current transformers are available with primary or secondary reconnection.

At the primary reconnectable current transformers it is possible to choose between two primary nominal currents, depending if the connection is made in parallel or in series. The primary nominal currents can only be realized in ratio 1:2.

At the secondary reconnectable current transformers the reconnection is realized by means of one or more secondary taps. Thereby the primary nominal current can be realized in various ratios.

Technical data:

	CTS36L43-T	CTS36L43U-T (primary reconnectable)	CTS36L43-T (secondary reconnectable)
Max. operating voltage U_m :	36 kV	36 kV	36 kV
Power frequency voltage:	70 kV	70 kV	70 kV
Lightning impulse voltage:	170 kV	170 kV	170 kV
Therm. nominal continuous rated current I_{cth} :	$1.2 \times I_N$	$1.2 \times I_N$	$1.2 \times I_N$
Therm. rated short-time current I_{th} :	$100 \times I_N$, 1 sec.; max. 40 kA, 1 sec.	$100 \times I_N$, 1 sec.; max. 40 kA, 1 sec.	$100 \times I_N$, 1 sec.; max. 40 kA, 1 sec.
Rated surge current I_{dyn} :	$2.5 \times I_{th}$	$2.5 \times I_{th}$	$2.5 \times I_{th}$
Primary nominal current:	5 A – 600 A	2x5 A – 2x300 A	...-5 A – 600-... A
Secondary nominal current:	5 A or 1 A	5 A or 1 A	5 A or 1 A
Nominal frequency:	50 / 60 Hz	50 / 60 Hz	50 / 60 Hz
Measuring CT accuracy classes:	1; 0.5; 0.5S; 0.2; 0.2S	1; 0.5; 0.5S; 0.2; 0.2S	1; 0.5; 0.5S; 0.2; 0.2S
Protection CT accuracy classes:	5P5; 5P10; 5P20; 5P30; 10P5; 10P10; 10P20; 10P30	5P5; 5P10; 5P20; 5P30; 10P5; 10P10; 10P20; 10P30	5P5; 5P10; 5P20; 5P30; 10P5; 10P10; 10P20; 10P30
Insulation class:	E	E	E
Cantilever strength:	5000 Nm	5000 Nm	5000 Nm
Weight:	approx. 51 kg	approx. 51 kg	approx. 51 kg

Subject to technical modifications without notice

Please note, that the above mentioned data are standard values. Other values on request.

Drawings:

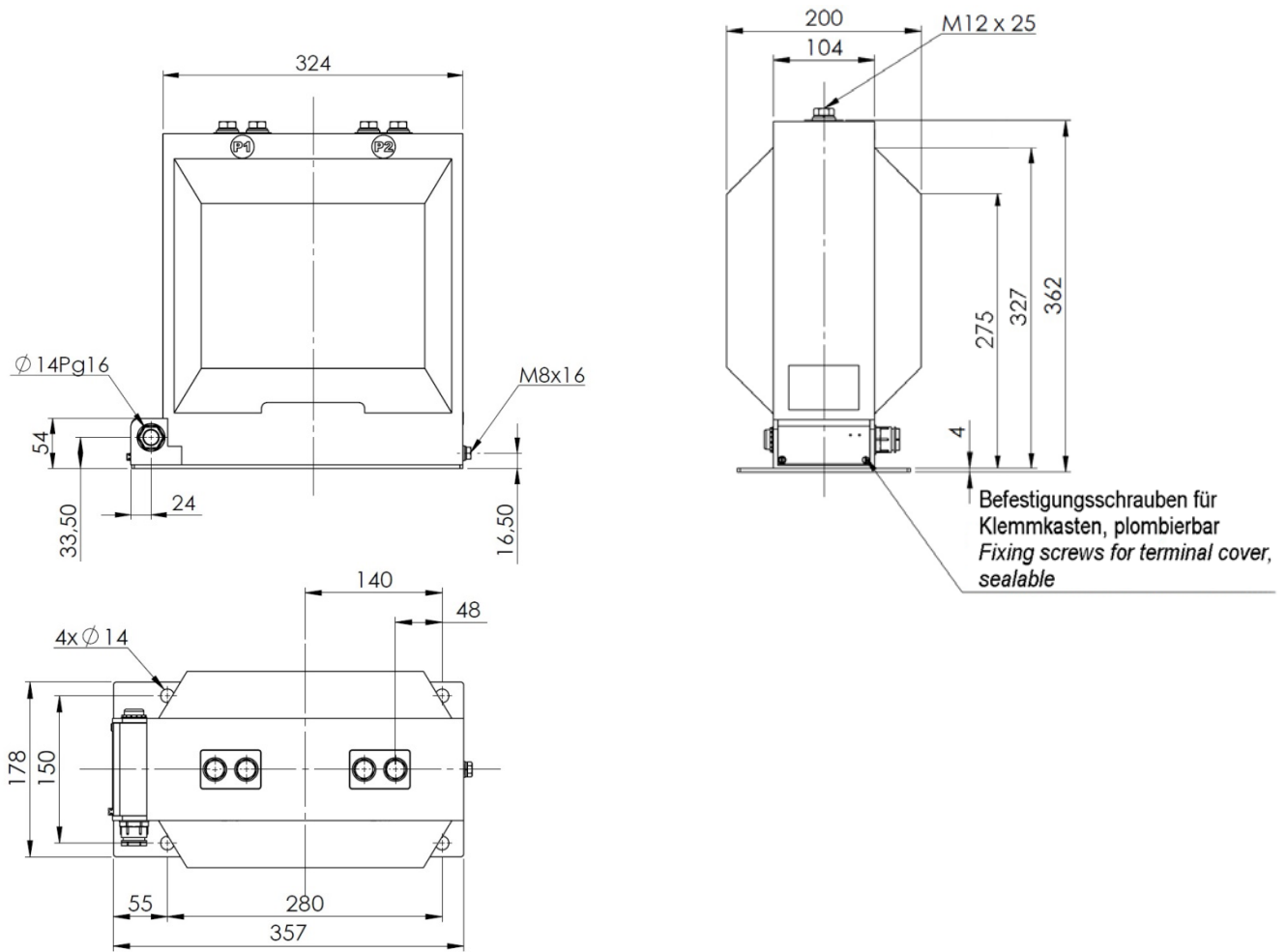

Primary connections:

up to 1250 A:

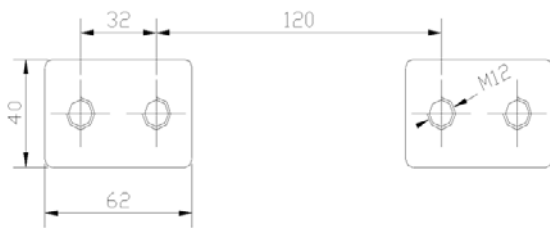

Primary reconnectable up to 1200 A:

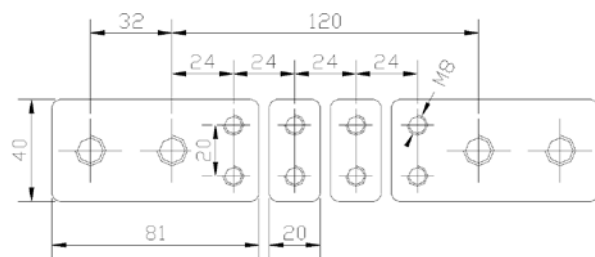

< 1250 A up to 3000 A:

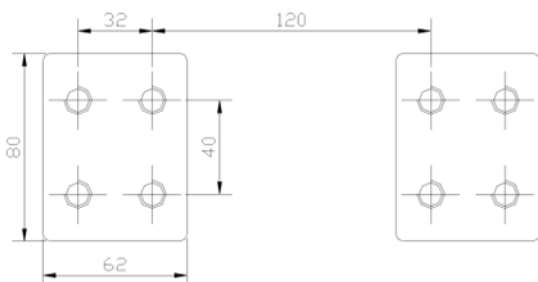

Terminal assignment – Primary reconnection:

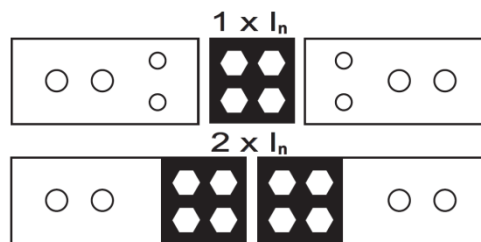

Single-pole isolated voltage transformer for indoor application

7.2 kV and 12 kV – Narrow type according to DIN 42600, part 9



Description:

Medium-voltage voltage transformers for indoor application, which are converting one or more primary voltages Proportional and in-phase into measurable and standardized secondary voltages.

These transformers are fully resin-hardened in polyurethane.

They can be used for measuring and protection purposes.

The medium-voltage voltage transformers are also available with two windings. The maximum quantity of windings depends on the chosen burden and accuracy class.

The single-pole isolated VTs can be equipped additionally with a winding for earth fault detection.

Optionally, the voltage transformers can be produced with secondary tap for two primary rated voltages.

Moreover it is possible to have these voltage transformers with a screw-fastened primary fuse (type VTS12M11-T + F) or to have it with an integrated primary fuse (type: VTS12M11F-T), to protect the surrounding distribution system.

Technical data:

	VTS12M11-T
Max. operating voltage U_m :	12 kV
Power frequency voltage:	28 kV
Lightning impulse voltage:	75 kV
Rated voltage factor:	$1.9 \times U_n / 8h$
Primary nominal voltage U_{PN}	3,000/ $\sqrt{3}$ V up to 11,000/ $\sqrt{3}$ V
Secondary nominal voltage U_{SN}	100/ $\sqrt{3}$ V or 110/ $\sqrt{3}$ V
Secondary nominal voltage for winding for earth fault detection (da-dn)	100/3 V or 110/3 V
Nominal burden and accuracy class	max. 25VA in cl.0.2 max. 75VA in cl.0.5 max. 150VA in cl.1
Nominal frequency	50 / 60 Hz
Insulation class:	E
Weight:	approx. 23 kg

Subject to technical modifications without notice

Please note, that the above mentioned data are standard values. Other values on request.

Drawings:

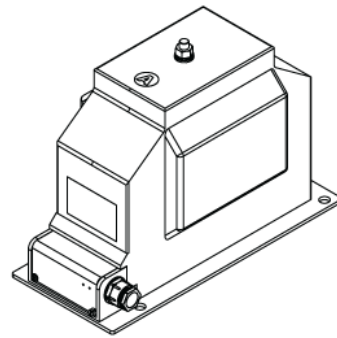
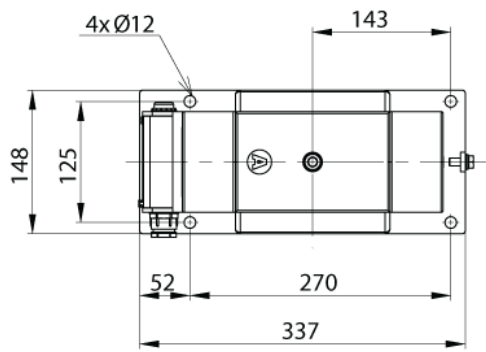
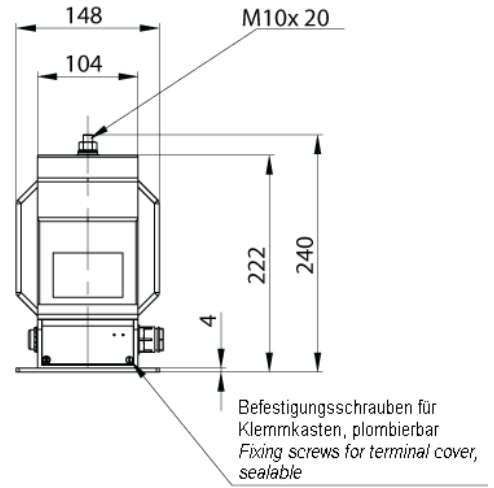
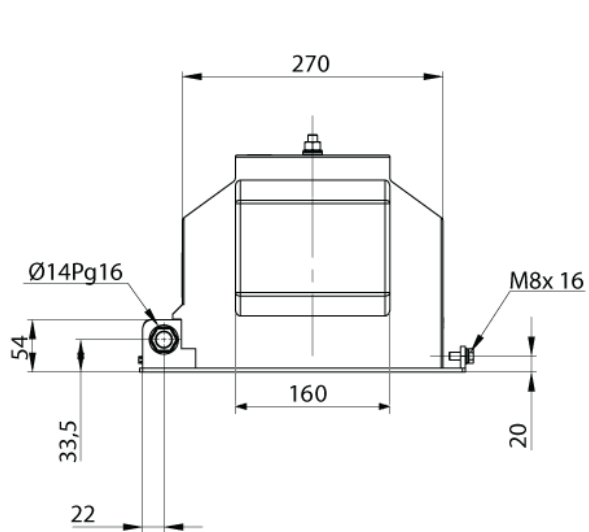

Double-pole isolated voltage transformer for indoor application

7.2 kV and 12 kV – Narrow type according to DIN 42600, part 9

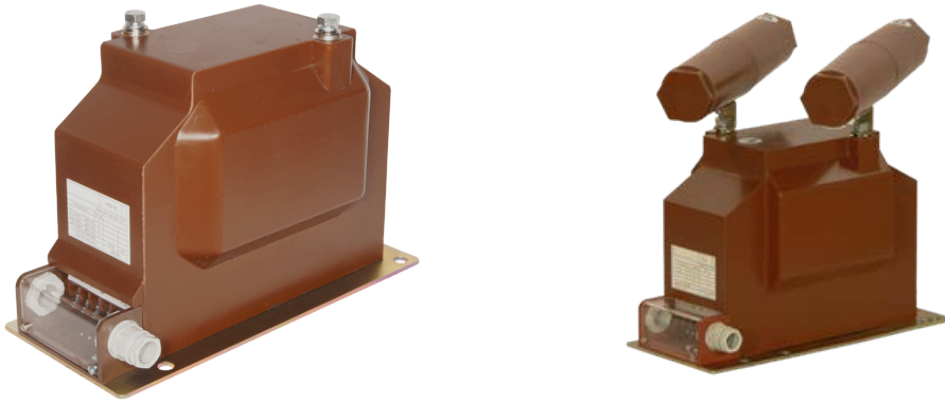

Description:

Medium-voltage voltage transformers for indoor application, which are converting one or more primary voltages proportional and in-phase into measurable and standardized secondary voltages. These transformers are fully resin-hardened in polyurethane.

They can be used for measuring and protection purposes.

The medium-voltage voltage transformers are also available with two windings. The maximum quantity of windings depends on the chosen burden and accuracy class.

Optionally, the voltage transformers can be produced with secondary tap for two primary rated voltages.

Moreover it is possible to have these voltage transformers with two screw-fastened primary fuses (type VTZ12M11-T + F), to protect the surrounding distribution system.

Technical data:

	VTZ12M11-T
Max. operating voltage U_m :	12 kV
Power frequency voltage:	28 kV
Lightning impulse voltage:	75 kV
Rated voltage factor:	1.2 x U_n / continuously
Primary nominal voltage U_{PN}	3,000 V up to 11,000 V
Secondary nominal voltage U_{SN}	100 V or 110 V
Nominal burden and accuracy class	max. 20VA in cl.0.2 max. 50VA in cl.0.5 max. 100VA in cl.1
Nominal frequency	50 / 60 Hz
Insulation class:	E
Weight:	approx. 23 kg

Subject to technical modifications without notice

Please note, that the above mentioned data are standard values. Other values on request.

Drawings:

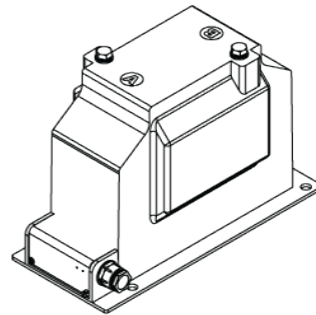
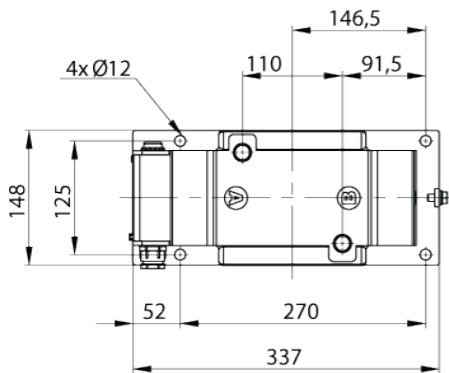
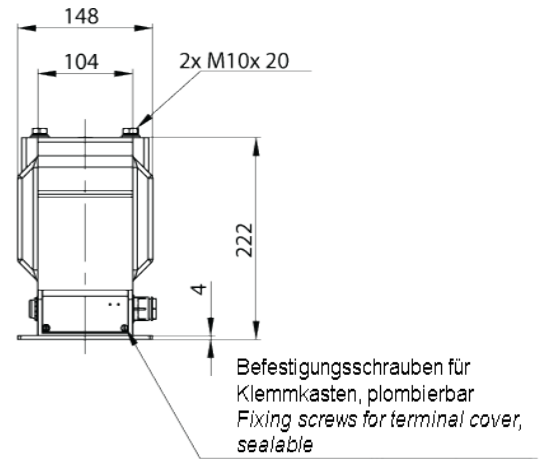
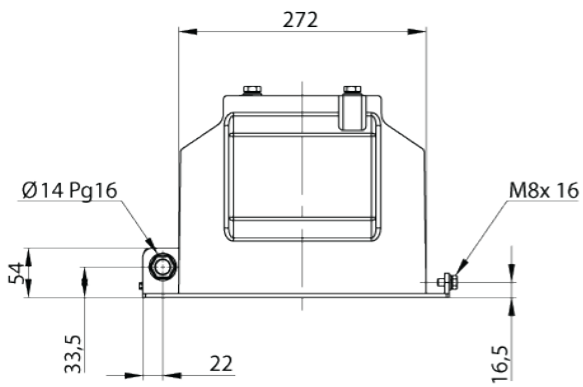

Single-pole isolated voltage transformer for indoor application

24 kV – Narrow type according to DIN 42600, part 9



Description:

Medium-voltage voltage transformers for indoor application, which are converting one or more primary voltages proportional and in-phase into measurable and standardized secondary voltages.

These transformers are fully resin-hardened in polyurethane. They can be used for measuring and protection purposes.

The medium-voltage voltage transformers are also available with two windings. The maximum quantity of windings depends on the chosen burden and accuracy class.

The single-pole isolated VTs can be equipped additionally with a winding for earth fault detection.

Optionally, the voltage transformers can be produced with secondary tap for two primary rated voltages

Moreover it is possible to have these voltage transformers with a screw-fastened primary fuse (type VTS24M32-T + F), to protect the surrounding distribution system.

Technical data:

	(E)VTS24M32-T
Max. operating voltage U_m :	24 kV
Power frequency voltage:	50 kV
Lightning impulse voltage:	125 kV
Rated voltage factor:	$1.9 \times U_n / 8h$
Primary nominal voltage U_{PN}	13,800/ $\sqrt{3}$ V up to 22,000/ $\sqrt{3}$ V
Secondary nominal voltage U_{SN}	100/ $\sqrt{3}$ V or 110/ $\sqrt{3}$ V
Secondary nominal voltage for winding for earth fault detection (da-dn)	100/3 V or 110/3 V
Nominal burden and accuracy class	max. 25VA in cl.0.2 max. 75VA in cl.0.5 max. 150VA in cl.1
Nominal frequency	50 / 60 Hz
Insulation class:	E
Weight:	approx. 28 kg

Subject to technical modifications without notice

Please note, that the above mentioned data are standard values. Other values on request.

Drawings:

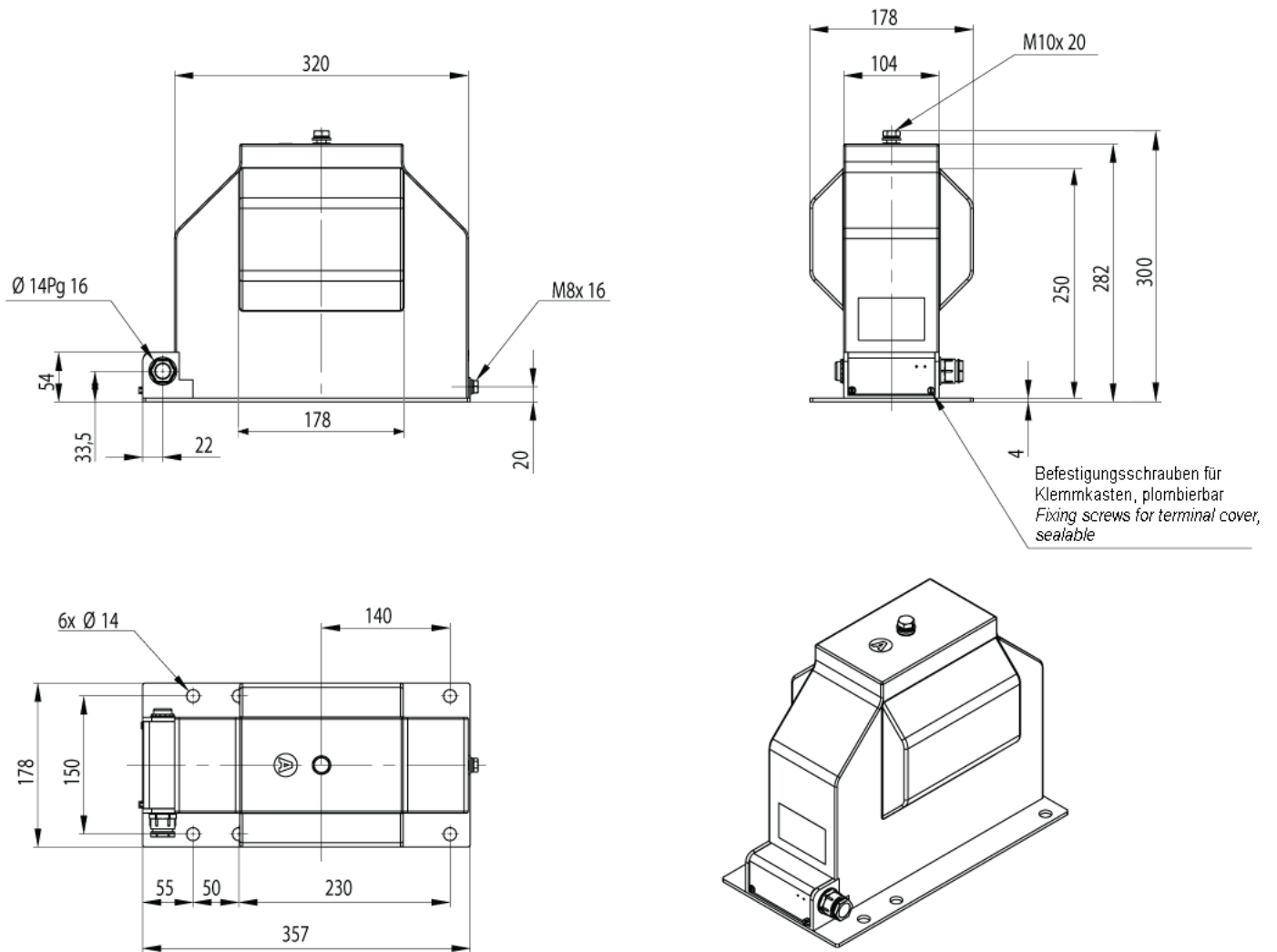

Double-pole isolated voltage transformer for indoor application

24 kV – Narrow type according to DIN 42600, part 9

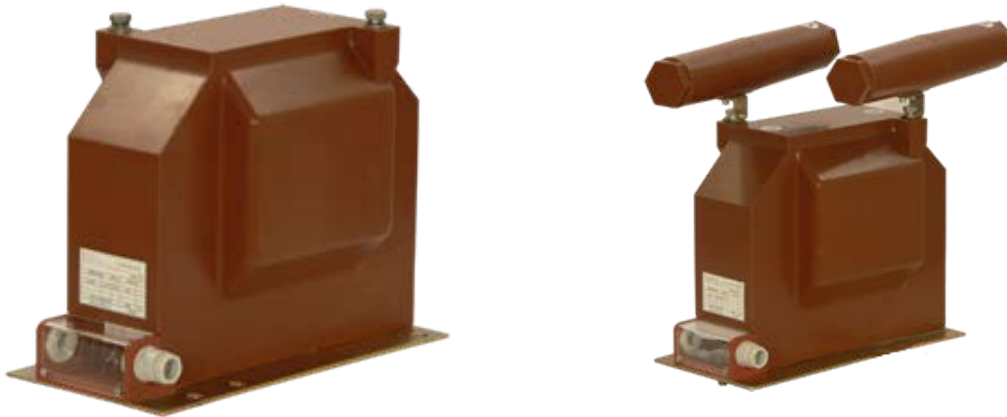

Description:

Medium-voltage voltage transformers for indoor application, which are converting one or more primary voltages proportional and in-phase into measurable and standardized secondary voltages.

These transformers are fully resin-hardened in polyurethane.

They can be used for measuring and protection purposes.

The medium-voltage voltage transformers are also available with two windings.

The maximum quantity of windings depends on the chosen burden and accuracy class.

Optionally, the voltage transformers can be produced with secondary tap for two primary rated voltages.

Moreover it is possible to have these voltage transformers with two screw-fastened primary fuses (type VTZ24M32-T + F), to protect the surrounding distribution system.

Technical data:

	VTZ24M32-T
Max. operating voltage U_m :	24 kV
Power frequency voltage:	50 kV
Lightning impulse voltage:	125 kV
Rated voltage factor:	1.2 x U_n / continuously
Primary nominal voltage U_{PN}	13,800 V up to 22,000 V
Secondary nominal voltage U_{SN}	100 V or 110 V
Nominal burden and accuracy class	max. 20VA in cl.0.2 max. 50VA in cl.0.5 max. 100VA in cl.1
Nominal frequency	50 / 60 Hz
Insulation class:	E
Weight:	approx. 28 kg

Subject to technical modifications without notice

Please note, that the above mentioned data are standard values. Other values on request.

Drawings:

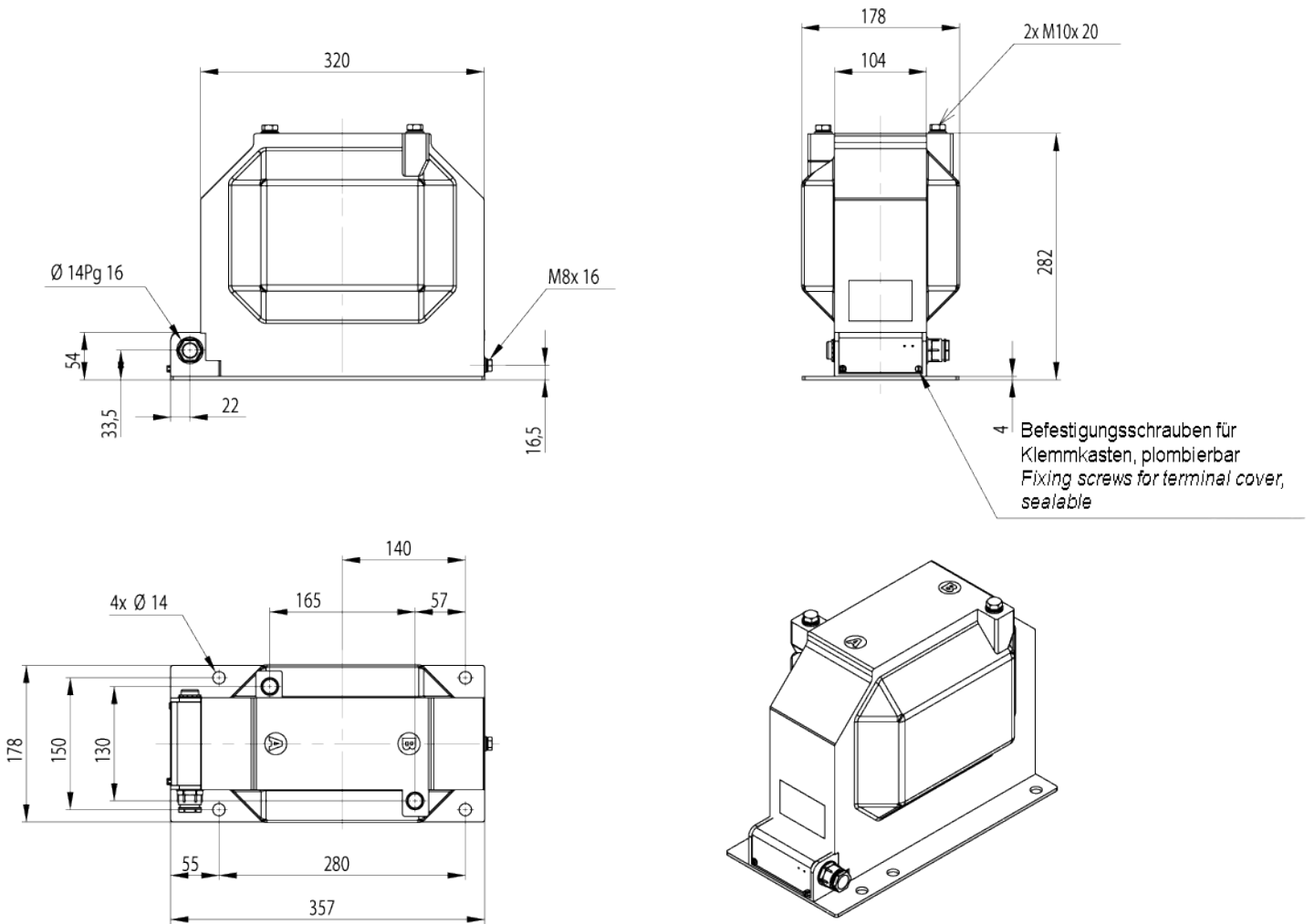

Single-pole isolated voltage transformer for indoor application

36 kV



Description:

Medium-voltage voltage transformers for indoor application, which are converting one or more primary voltages proportional and in-phase into measurable and standardized secondary voltages.

These transformers are fully resin-hardened in polyurethane.

They can be used for measuring and protection purposes.

The medium-voltage voltage transformers are also available with two windings.

The maximum quantity of windings depends on the chosen burden and accuracy class.

The single-pole isolated VTs can be equipped additionally with a winding for earth fault detection.

Optionally, the voltage transformers can be produced with secondary tap for two primary rated voltages.

Moreover it is possible to have these voltage transformers with a screw-fastened primary fuse (type VTS36M44-T + F), to protect the surrounding distribution system.

Technical data:

	VTS36M4-T
Max. operating voltage U_m :	36 kV
Power frequency voltage:	70 kV
Lightning impulse voltage:	170 kV
Rated voltage factor:	$1.9 \times U_n / 8h$
Primary nominal voltage U_{PN}	24,000/ $\sqrt{3}$ V up to 33,000/ $\sqrt{3}$ V
Secondary nominal voltage U_{SN}	100/ $\sqrt{3}$ V or 110/ $\sqrt{3}$ V
Secondary nominal voltage for winding for earth fault detection (da-dn)	100/3 V or 110/3 V
Nominal burden and accuracy class	max. 25VA in cl.0.2 max. 75VA in cl.0.5 max. 150VA in cl.1
Nominal frequency	50 / 60 Hz
Insulation class:	E
Weight:	approx. 32 kg

Subject to technical modifications without notice

Please note, that the above mentioned data are standard values. Other values on request.

Drawings:

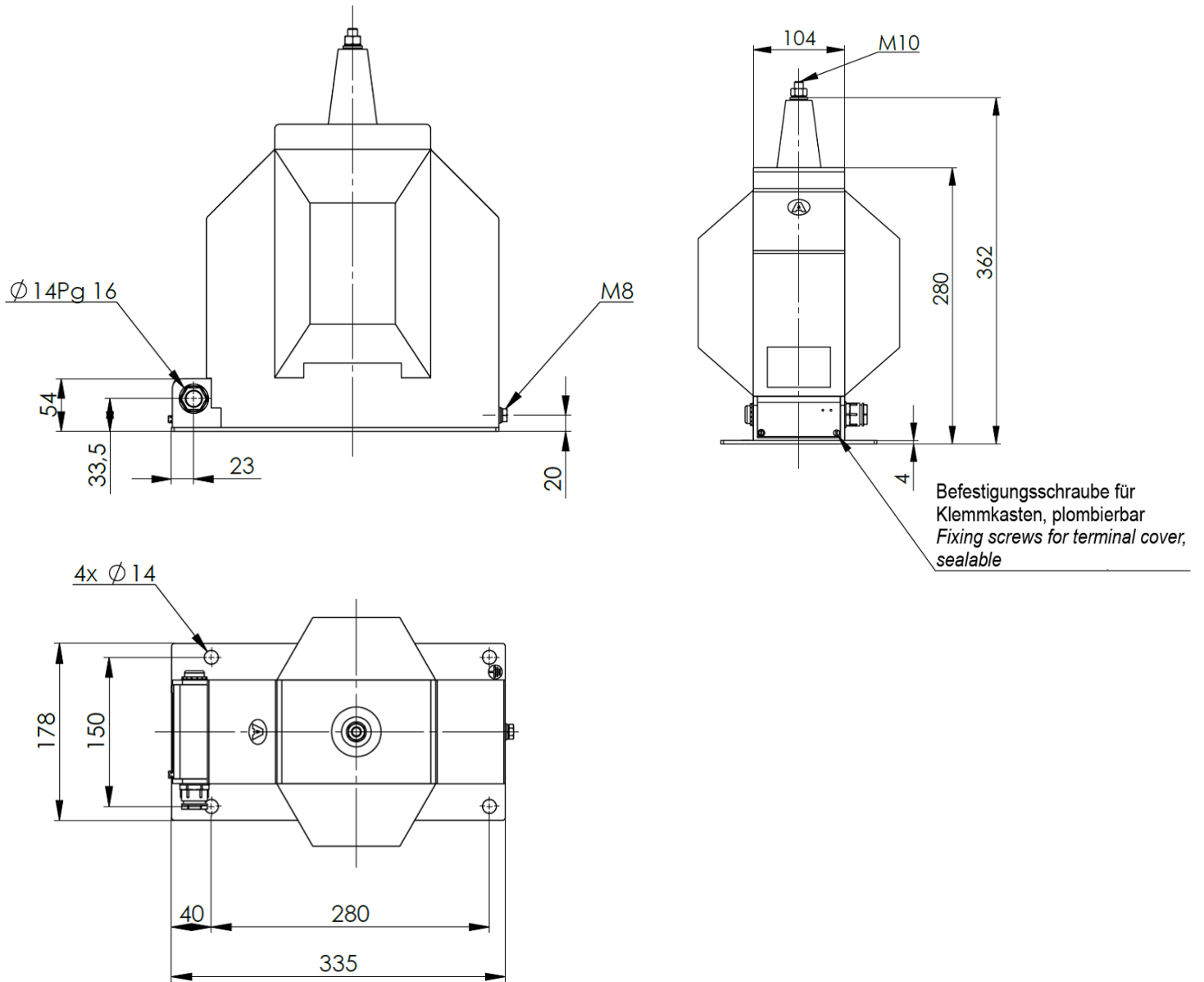

CTO

Split-core current transformer, fully resin-hardened for indoor applications

0.72 kV / 1.2 kV



Features / Benefits

- Split-core current transformer suitable for measuring or protection purposes, depending on the design of the CT
- The modular design of this series allows a large number of varieties within the different CT sizes (please see next page for details about the different dimensions)
- Max. operating voltage: 0.72/3/- kV or 1.2/6/- kV; if the primary conductor is suitably insulated the CT can also be used above 0.72 kV or 1.2 kV
 - Primary current range: 50 A ... 5000 A
 - Secondary currents: 1 A, 2 A or 5 A
 - Rated burden: 2.5 VA ... 30 VA
 - Accuracy classes: 0.2S; 0.2; 0.5S; 0.5; 1; 3
 - Over-current rated limiting factor for measuring cores: FS5 or FS10
 - Protection classes: 5P / 10P / PX
 - Over-current rated limiting factor for protection cores: 5, 10, 15, 20, 30

Dimensions:

Primary opening diameter: max. 400 mm
 Transformer width: 100 - 600 mm
 Transformer depth: 60 - 300 mm

Please see next page for details about the different dimensions.

General technical specifications:

Therm. nominal continuous rated current I_{cth} : 1,0 x I_N or 1,2 x I_N , other values upon request
 Therm. nominal short-time current I_{th} : Min. 100 x I_N / 1 sec., other values upon request
 Rated dynamic current I_{dyn} : 2,5 x I_{th}
 Max. operating voltage U_m : 0,72 kV or 1,2 kV
 Isolation test voltage: 3 kV, U_{eff} , 50 Hz, 1 min. or 6 kV, U_{eff} , 50 Hz, 1 min.
 Rated frequency: 50 Hz or 60 Hz, other values upon request
 Isolation class: E
 Applicable technical standards: DIN EN 61869, part 1 + 2 (formerly DIN EN 60044-1)

Further information:

- Measuring systems fully hardened with Polyurethane resin
- The current transformers type CTO are intended for subsequent installation in existing low-voltage switchgear. In addition, there are customers who use these current transformers in medium-voltage switchgears, if the primary conductor is suitably insulated. Further applications are wind turbines, facilities for power generation on ships, power distribution systems, etc.
- The two parts of the current transformer are held together by four screws with springs or spring clips on the sides, which ensures a permanent contact pressure.
- The secondary connection terminals are factory-fitted with M5 screws. A clear plastic cover serves as an touch protection.
- Protection type: Housing: IP54, Terminal cover: IP20
- Operating temperature: $-5^{\circ}\text{C} < T < +40^{\circ}\text{C}$
- Storage temperature: $-25^{\circ}\text{C} < T < +70^{\circ}\text{C}$
- Mounting of CT by means of a baseboard attached to the resin body
- Packaging unit: 1 pc.
- Customs tariff number: 85043129

Dimension drawings:

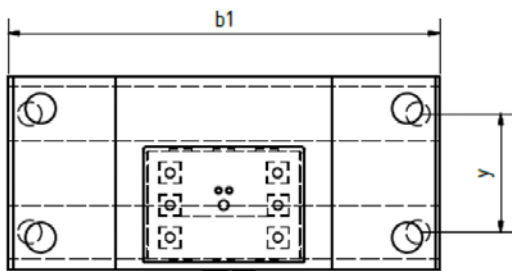
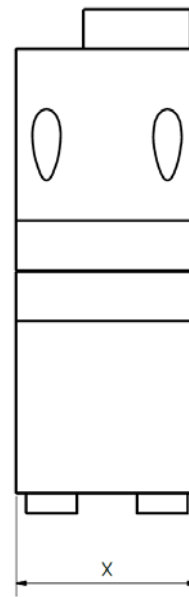
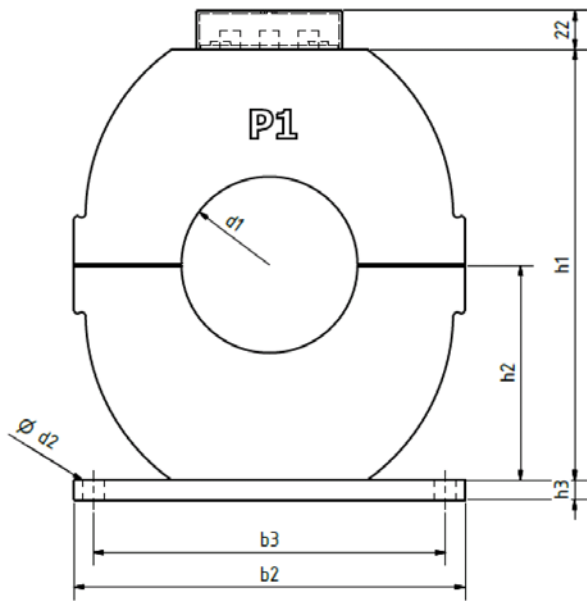

Frame size	x*	y*
B ¹⁾	90	60
C ¹⁾	120	90
D	150	120
E	200	170
F	250	220
G	300	270

* Dimension x + y depends on the type and number of measuring systems installed..

¹⁾ The dimension „y“ for frame size B is 105 mm and for frame size C is 135 mm at type CTO 100 and CTO 120.

Determination of current transformer type:

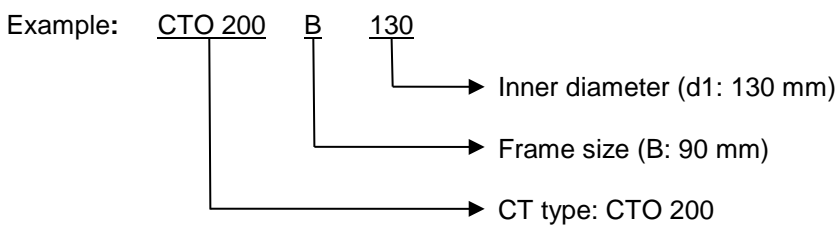

CT type	b1	b2	b3	max. d1	d2	h1	h2	h3	max. frame size	Deliverable
CTO 100	100	100	60	50	6	120	60	3	B - C	yes
CTO 120	120	120	70	65	6	135	67,5	3	B - C	yes
CTO 135	135	150	120	90	9	150	75	10	B - C	yes
CTO 150	150	150	120	110	9	170	85	10	B - C	yes
CTO 170	170	170	150	110	11	185	92,5	10	B - C	yes
CTO 200	200	200	180	140	11	200	100	10	B - G	yes
CTO 250	250	250	230	160	11	290	145	10	B - G	yes
CTO 300	300	300	280	210	11	340	170	10	B - G	yes
CTO 350	350	350	330	270	11	390	195	10	B - G	yes
CTO 500	500	500	440	400	11	500	250	10	B - G	yes
CTO 600	600	600	500	400	11	640	320	10	B - G	yes

CTR

Single-piece current transformers, fully resin-hardened for indoor applications

0.72 kV / 1.2 kV

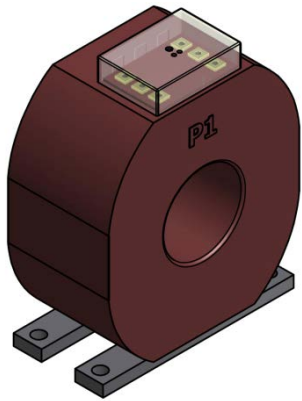

Features / Benefits

- Single-piece current transformer suitable for measuring or protection purposes, depending on the design of the CT
- The modular design of this series allows a large number of varieties within the different CT sizes (f.e. two cores in one unit); please see next page for details about the different dimensions
- Max. operating voltage: 0.72/3/- kV or 1.2/6/- kV; if the primary conductor is suitably insulated the CT can also be used above 0.72 kV or 1.2 kV
 - Primary current range: 50 A ... 5000 A
 - Secondary currents: 1 A, 2 A or 5 A
 - Rated burden: 2.5 VA ... 30 VA
 - Accuracy classes: 0.2S; 0.2; 0.5S; 0.5; 1; 3
 - Over-current rated limiting factor for measuring cores: FS5 or FS10
 - Protection classes: 5P / 10P / PX / TPS / TPY
 - Over-current rated limiting factor for protection cores: 5, 10, 15, 20, 30

Dimensions:

Primary opening diameter: max. 360 mm
 Transformer width: 100 - 500 mm
 Transformer depth: 60 - 300 mm

Please see next page for details about the different dimensions.

General technical specifications:

Therm. nominal continuous rated current I_{cth} : 1,0 x I_N or 1,2 x I_N , other values upon request
 Therm. nominal short-time current I_{th} : Min. 100 x I_N / 1 sec., other values upon request
 Rated dynamic current I_{dyn} : 2,5 x I_{th}
 Max. operating voltage U_m : 0,72 kV or 1,2 kV
 Isolation test voltage: 3 kV, U_{eff} , 50 Hz, 1 min. or 6 kV, U_{eff} , 50 Hz, 1 min.
 Rated frequency: 50 Hz or 60 Hz, other values upon request
 Isolation class: E
 Applicable technical standards: DIN EN 61869, part 1 + 2 (formerly DIN EN 60044-1)

Further information:

- Measuring systems fully hardened with Polyurethane resin
- The current transformers type CTR are intended for installation in low-voltage switchgear. In addition, there are customers who use these current transformers in medium-voltage switchgears, if the primary conductor is suitably insulated. Further applications are wind turbines, facilities for power generation on ships, power distribution systems, etc.
- The current transformers are manufactured in a standard version with a round window opening. But optionally a rectangular window opening for bus bar mounting is possible to produce.
- The secondary connection terminals are factory-fitted with M5 screws. A clear plastic cover serves as an touch protection.
- Protection type: Housing: IP54, Terminal cover: IP20
- Operating temperature: $-5^{\circ}\text{C} < T < +40^{\circ}\text{C}$
- Storage temperature: $-25^{\circ}\text{C} < T < +70^{\circ}\text{C}$
- Mounting of CT by means of a baseboard attached to the resin body (optionally: frontal threaded bushes)
- Packaging unit: 1 pc.
- Customs tariff number: 85043129

Dimension drawings:

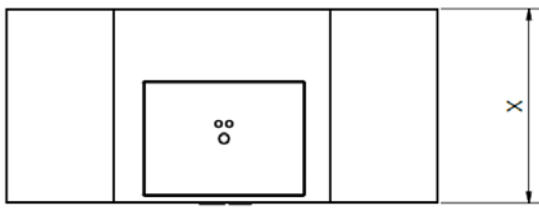
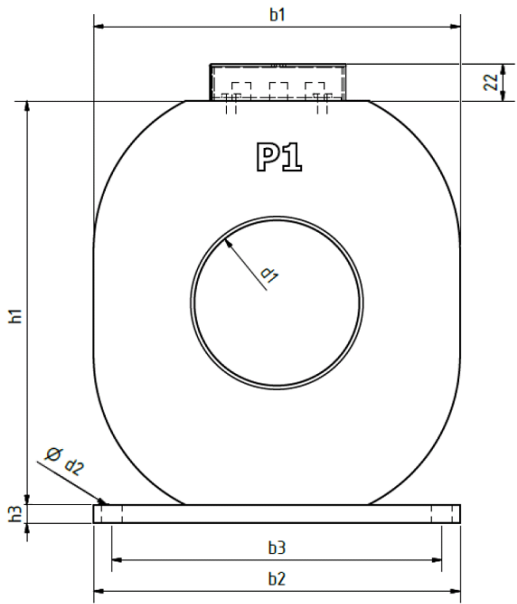

Frame size	x*	y*
A ¹⁾	60	30
B ¹⁾	90	60
C ¹⁾	120	90
D	150	120
E	200	170
F	250	220
G	300	270

* Dimension x + y depends on the type and number of measuring systems installed.

¹⁾ The dimension „y“ for frame size A is 75 mm, size B it's 105 mm and size C it's 135 mm at type CTR 100; CTR 110 and CTR 120.

Determination of current transformer type:

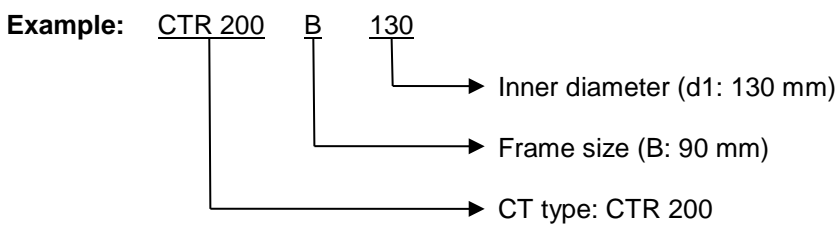

CT type	b1	b2	b3	max. d1	d2	h1	h2	h3	max. frame size	Deliverable
CTR 100	100	100	80	60	9	110	55	5	C	yes
CTR 110	110	110	90	70	9	120	60	5	C	yes
CTR 120	120	120	100	75	9	130	65	5	C	on demand
CTR 135	135	150	130	90	9	150	75	10	C	yes
CTR 150	150	150	130	110	9	165	82,5	10	D	yes
CTR 170	170	170	150	110	11	185	97,5	10	D	yes
CTR 200	200	200	180	140	11	220	110	10	E	yes
CTR 250	250	250	230	150	11	270	135	10	E	yes
CTR 300	300	300	280	210	11	330	165	10	F	yes
CTR 350	350	350	330	250	11	380	190	10	F	on demand
CTR 400	400	400	370	300	13	430	215	15	G	on demand
CTR 500	500	500	440	360	13	530	265	15	G	yes

ASG 106

Tube current transformer, fully resin-hardened for indoor applications

0.72 kV



Features / Benefits

- Tube current transformer with up to 4 measuring systems integrated in one housing
- Combination of measuring and protection transformers in one housing is possible
- Max. operating voltage: 0.72/3/- kV; if the primary conductor is suitably insulated the CT can also be used above 0.72 kV
- Primary current range: 40 A ... 1250 A
- Secondary currents: 1 A, 2 A or 5A
- Rated burden: 2.5 VA ... 30 VA
- Accuracy classes: 0.2S; 0.2; 0.5S; 0.5; 1; 3
- Over-current rated limiting factor for measuring cores: FS5 or FS10
- Protection classes: 5P / 10P / PX
- Over-current rated limiting factor for protection cores: 5, 10, 15, 20, 30

Dimensions:

Primary opening diameter: 106 mm
 Transformer width: 190 mm
 Transformer depth: 50, 100, 170, 214 mm*

Please see next page for details about the different dimensions.

General technical specifications:

Therm. nominal continuous rated current I_{cth} : $1.2 \times I_N$,
 other values upon request
 Therm. nominal short-time current I_{th} : 25 kA / 3 sec.,
 other values upon request
 Rated dynamic current I_{dyn} : $2.5 \times I_{th}$
 Max. operating voltage U_m : 0.72 kV
 Isolation test voltage: 3 kV, U_{eff} , 50 Hz, 1 min.
 Rated frequency: 50 Hz, other values upon request
 Isolation class: F
 Applicable technical standards: DIN EN 61869, part 1 + 2
 (formerly DIN EN 60044-1)

Further Information:

- Measuring systems fully hardened with Polyurethane resin
- Full resin hardening and the used high-quality materials allow the application under extreme mechanical and climatic conditions (f.e. application close to generator)
- Resin material with high fire safety (UL94-V0)
- Current transformer type tested by Siemens AG
- The current transformers type ASG 106 are intended for installation in low-voltage switchgear. In addition, there are customers who use these current transformers in medium-voltage switchgears, if the primary conductor is suitably insulated. Further applications are wind turbines, facilities for power generation on ships, power distribution systems...
- Measuring cores with PTB approval available
- 4 different housing depths allow the realisation of different customer requirements
- Reduction of external wiring by means of flexible secondary connection cables (3.6 m, 4 mm², other lengths and profiles upon request)
- Flexible terminal connections are protected by additional textile braided sleeving.
- Influence of cable length is taken into account in the interpretation of the measurement systems
- Operating temperature: $-5^{\circ}\text{C} < T < +60^{\circ}\text{C}$
- Storage temperature: $-25^{\circ}\text{C} < T < +70^{\circ}\text{C}$
- Housing material: ABS, self-extinguishing, UL94-V0
- Mounting of current transformers by with 2 pieces (optional 4 pieces) hexagon bolts M8x30
- Packaging unit: 1 pc.
- Customs tariff number: 85043129

Measurements:

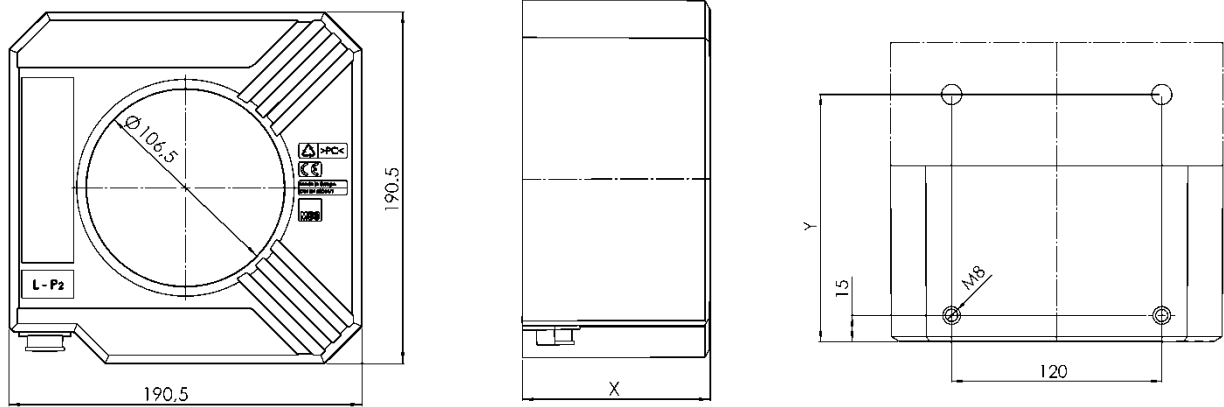

Housing depth x*	50 mm	100 mm	170 mm	214 mm
Measurement y (optional!)	-	85 mm	155 mm	199 mm

*Dimension x + y depends on the type and number of measuring systems installed.

CHECKLIST

Required informations for enquiries or purchase orders of Medium-Voltage Current Transformers

- ✓ Primary rated current (for each core) e.g. 100 A
 - ✓ Secondary rated current (for each core) e.g. 5 A
 - ✓ Core 1: rated power + accuracy class e.g. 5VA Kl. 0,2 S
 - ✓ Core 2: (if existing) rated power + accuracy class e.g. 5VA Kl. 0,5
 - ✓ Core 3: (if existing) rated power + accuracy class e.g. 10VA Kl. 5P10
 - ✓ Rated frequency e.g. 50 Hz
 - ✓ Therm. rated uninterrupted current I_{cth} e.g. 1,2 x I_N oder 120 %
 - ✓ Therm. rated short-time current / period I_{th} e.g. 20 kA / 1 Sek.
 - ✓ Rated insulation level e.g. 12/28/75 kV
- Please note, the dimensions of primary wire or the requested inner diameter is required for winding type- and split-core current transformers (Type CTR + CTO).
(Not required for support type current transformers, type CTS!)

Required informations for enquiries or purchase orders of Medium-Voltage Voltage Transformers

- ✓ Primary rated voltage e.g. $10.000/\sqrt{3}$ V
- ✓ Secondary rated voltage (for each winding) e.g. $100/\sqrt{3}$
- ✓ Winding 1: rated power + accuracy class e.g. 15VA Kl. 0,2
- ✓ Winding 2: (if existing) rated power + accuracy class e.g. 15VA Kl. 0,5
- ✓ Winding 3: (if existing) rated power + accuracy class e.g. 30VA Kl. 3P (da-dn)
- ✓ Rated frequency e.g. 50 Hz
- ✓ Rated voltage factor e.g. $1,9 \times U_N / 8h$
- ✓ Rated insulation level e.g. 12/28/75 kV

Above-mentioned definitions according DIN/EN/IEC 61869-1/2/3



The data contained in the product catalog are to the best of my knowledge and belief. Changes and errors are reserved. similar pictures provide any terms within the meaning of § represents 305 I BGB. There are notes without independent regulatory content that bring only expressed that the information contained in the catalog so far are preliminary and non-binding, as before or at the conclusion of a contract yet can be corrected. A contractual arrangements content, in particular a possible restriction of the rights of the contracting party in liability-or warranty legal terms, these instructions can not be removed.

Gilgen, Müller & Weigert (GMW) GmbH & Co. KG

Am Farnbach 4A
90556 Cadolzburg

Tel: +49 (0) 9103 7129-0
Fax: +49 (0) 9103 7129-205/207
E-Mail: info@g-mw.de
Internet: www.g-mw.de

Manager: Prof. Dr. h.c. Wolfgang Gilgen

TAX: DE815535316

For further information of GMW, we would like to recommend you to visit our website:

www.g-mw.de