

SW-BCD-94

- ▣ universal indicator
with serial and parallel input
- ▣ 4 strobe inputs; 16 data inputs
- ▣ RS-485 / Modbus RTU
- ▣ SLAVE

The **SW-BCD-94** indicator can be used as the indicator output for PLCs to display data in the binary, bcd or byte format or to show typical information transmitted over the RS-485 interface.

Depending on the parameter settings, the indicator can display:

- digits (0 - 9), with programmable decimal point,
- binary data (0 - 9, A - F), showing the statuses of e.g. the address lines, data lines, etc.
- various messages and text which can be created on the 7-segment digital displays.

- choice of number of strobe inputs,
- choice of input type (serial / parallel),
- choice of type of displayed data,
- choice of strobe signal,
- password protected,
- programmable decimal point position,
- available with AC and DC power supply versions.

Exemplary pin assignment

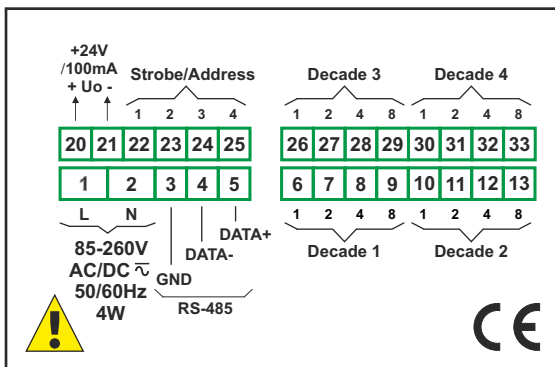

Ordering

SW-BCD-94-A700-1-X-XX1

options:

- 00 : no options
- 01 : IP 65 frame
- 08 : operating temp.
-20°C ÷ +50°C

power supply:

- 3 : 24V AC/DC
- 4 : 85V - 260V AC/DC



Typical applications

1. Indicator of physical values sent from a PLC, data transfer to the process monitoring centre over the RS-485 interface.

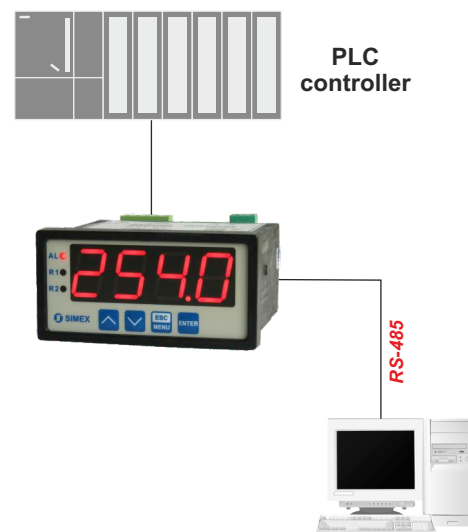

Technical data

- Power supply:** 19V ÷ 50V DC; 16V ÷ 35V AC or 85 ÷ 260V AC/DC, all separated
- Power consumption:** for 85 ÷ 260V AC/DC and 16V ÷ 35V AC power supply: max. 4,5 VA; 19V ÷ 50V DC power supply: max. 4,5 W
- Display:** LED, 4 x 20 mm, red (green - on request)
- Displayed values range:** 4 digits (-999 ÷ 9999 plus decimal point) or any of character indication in range of 7-segments display
- Parallel inputs:** 4 strobe inputs; 16 data inputs (4 decades, 4 bits/decade)
- Input levels:** low: 0 V ÷ 2 V; high: 4 V ÷ 24 V
- Minimum strobe pulse width:** 100 µs
- Power supply output:** 24V DC +5%, -10% / max.100 mA, stabilized
- Communication interface:** RS-485 (Modbus RTU), not galvanically insulated
- Transmission speed:** adjustable in range from 1200 to 115200 bit/sek.
- Transmission parameters:** 8N1 and 8N2
- Operating temperature:** 0°C ÷ +50°C (standard), -20°C ÷ +50°C (option)
- Storage temperature:** -10°C ÷ +70°C (standard), -20°C ÷ +70°C (with option 08)
- Protection class:** IP 65 (front), available additional frame IP 65 for panel cut-out sealing; IP 20 (case and connection clips)
- Case:** board
- Case material:** NORYL - GFN2SE1
- Case dimensions:** 96 x 48 x 100 mm
- Panel cut-out dimensions:** 90,5 x 43 mm
- Installation depth:** min. 102 mm
- Board thickness:** max. 5 mm