



RGB Technology[®]
MODERN TECHNOLOGIES

INSTALLATION MANUAL PM AND PS SERIES PRICE MODULES



1 Manufacturer

RGB Technology Sp. z o. o.
Karola Mytnika 28
75-129 Koszalin
POLAND

2 Specification

Available LED colours:

- white,
- amber
- red,
- blue,
- green,
- yellow.

3 Transport and storage

The device is sensitive to mechanical damage. Care should be taken to properly protect the device during transport so as to eliminate any damage on the way. The device should be stored at temperature not less than -25°C and not higher than +60°C and at humidity below 99% RH.

4 Device installation

NOTICE!

Before any installation or maintenance operations refer to the manual supplied by the manufacturer. Improper connection to the power supply, incautious device installation, or improper use may cause property damage. In addition, failure to follow the manufacturer's instructions may void the warranty.

NOTICE!

Remember that all components should be mounted with the cables facing down.

NOTICE!

It is forbidden to make any additional mounting points or holes in the device assembly components. Each individual LED module (digit) has a specific position in the price module. The key to the proper functioning of the system is to make appropriate electrical connections.

5 Installation of LED modules

Each individual LED module (digit) has its address. The address number is located on the top edge of the junction box (Fig. 1).

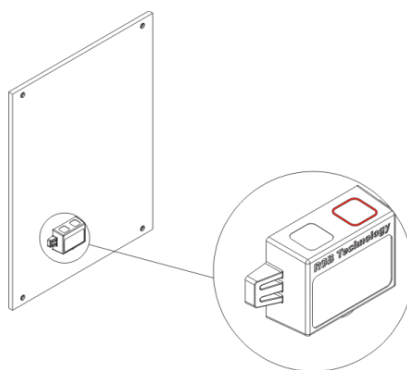

Fig. 1

Table 1 shows correct arrangement of the digits in the price pylon:

Table 1

Digit numbers (Fig. 2)	PYLON					
	6	5	4	3	2	1
Digit addresses	5	4	3	2	1	0

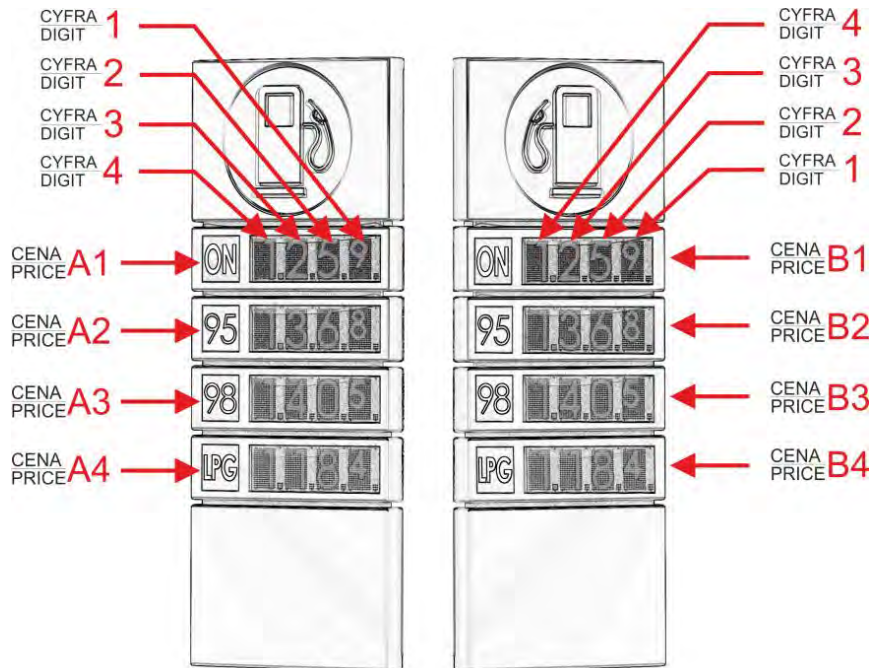

Fig. 2

Figure 2 shows an example of a price pylon consisting of four PM25-4U price modules per side¹. The numbering of the price modules starts from the top as shown in the figure above. The first price module from the top should be connected to the A1 connector in the controller, the next - to the A2 connector etc. The price modules may be mounted in any position in the price pylon - the key to proper functioning is the correct connection of the modules to the appropriate connectors in the controller. The price modules are characterized by ingress protection rating IP-67, and the controller - by ingress protection rating IP-65.

A remote control antenna should be located at a minimum height of 2 m on the side at which a remote control will be used. Make sure that there are no major interference sources on the transmission path. The remote control should be operated at least 10 cm away from any covers, especially large metal structures.

¹ explanatory figure

6 Connections in collective boxes

Connections in collective boxes are made using WAGO clamp connectors. To properly connect a cable to the connector, pull a free lever up, then insert the cable to the limit and latch the lever. Always make sure that the cable is firmly held by the connector. When you connect more than 5 cores to a WAGO connector, make a bridge with another WAGO connector (Fig. 3).



Fig. 3

7 Connection of price modules to the controller

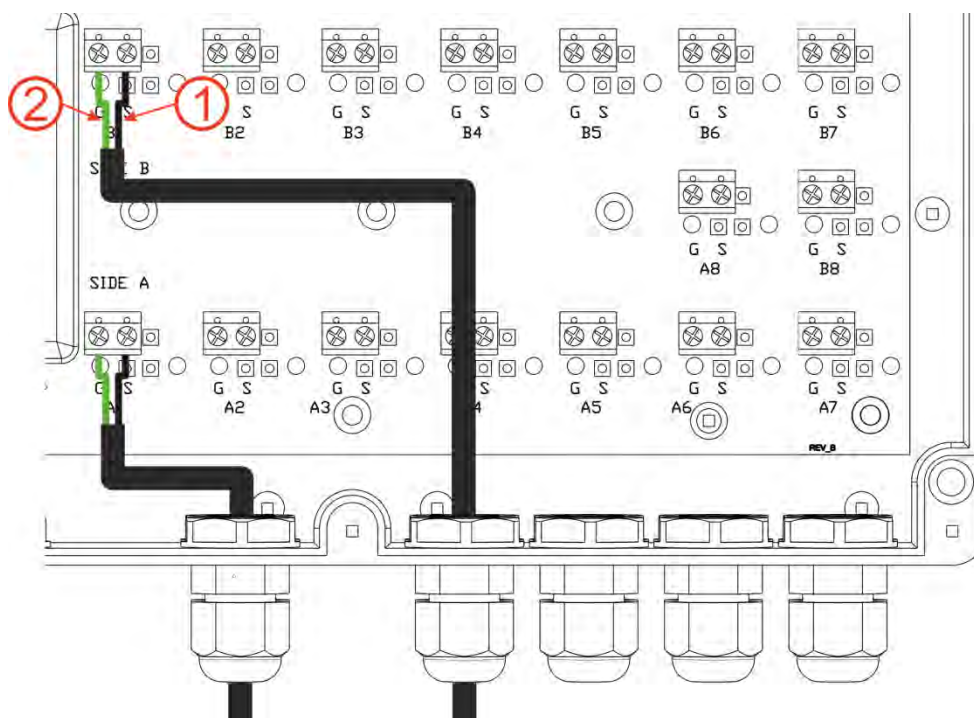

Fig. 4

The controller has 16 connectors, 8 per each side of the pylon, to which the user connects price modules. The number of connectors used depends on the number of the price modules in use. The price modules must be connected in accordance with the order of their installation on the price pylon, the diagram of which is shown in Figure 2. The price module connection consists in threading the cable coming out of the price module collective box through the gland² and in connecting it to the appropriate connector (A1 ÷ A8, B1 ÷ B8) inside the controller housing. A white signal cable (1) should be connected to the "S" connector and a green (or brown) signal cable (2) to the "G" connector.

Connector markings	Core colours	Alternative core colours	Notes
S	White	White	Signal line for price module
G	Green	Brown	GND line

² After threading the cable, twist the gland so that the cable is fixed.

8 Electrical connection diagram

8.1 Electrical diagram of an example price pylon consisting of five price modules per side.

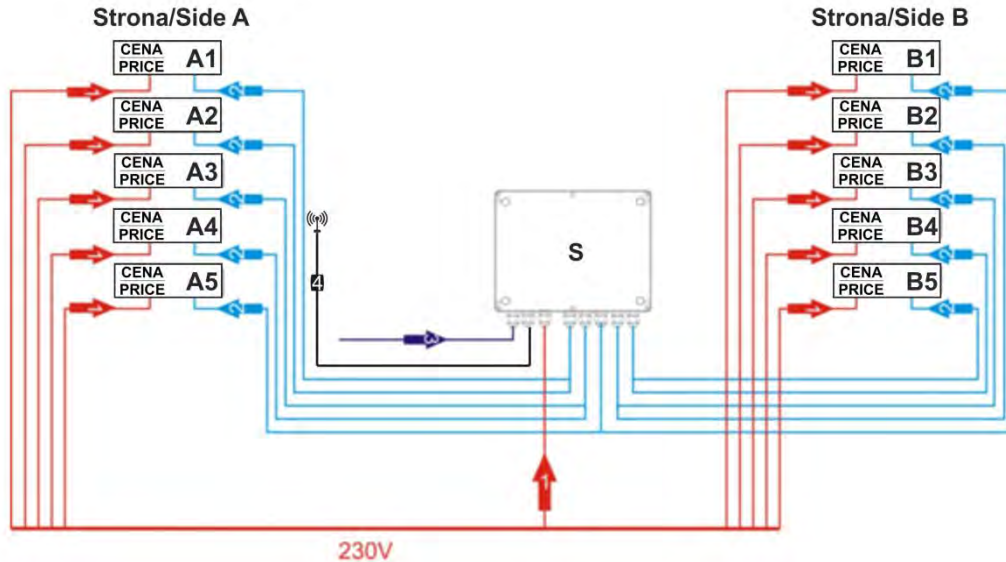

Fig. 5

Legend:

A1, B1, ... – price modules' numbers,

S - controller

Red -1- - 3 x 1mm² cable of the length of 5 m (core markings: blue, brown, yellow-and-green) powering the price modules and the controller,

Red -230V- –230V power supply,

Blue -2- - 2 x 0.5 mm² signal cable of the length of 5 m (core markings: white, green; alternative core markings: white, brown) connecting the price modules with the controller,

Dark blue -3- - 2 x 0.5 mm² cable of the length of 2 m (core markings: black, red) light sensor input.

Black -4-- - 5-metre long antenna cable.

Notice!

Make sure that all components should be mounted with the cables facing down!

8.2 Pylon controller diagram

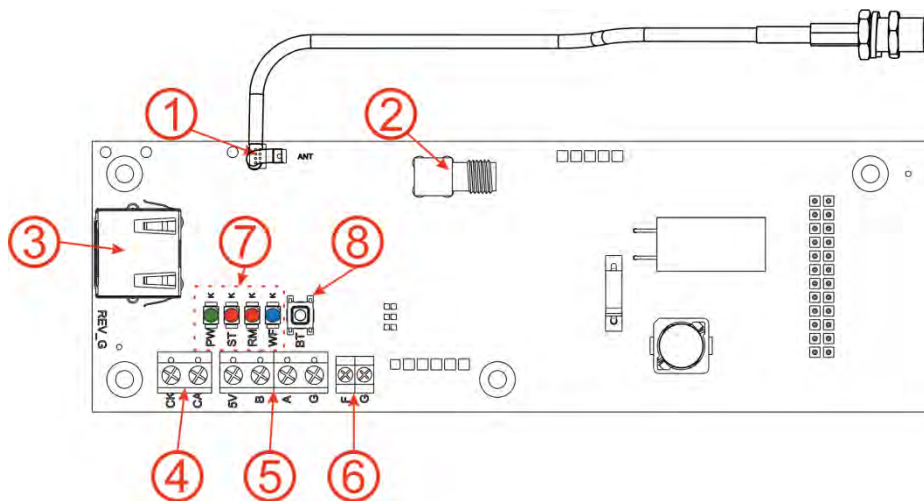

Fig. 6

Legend:

- | | |
|--------------------------------|---|
| 1 . Antenna connector: | - remote control antenna terminated with the SMA connector, |
| 2. Wi-Fi connector | - Wi-Fi connector - optional item, |
| 2. Ethernet connector: | - connector enabling communication with a computer via an Ethernet cable, |
| 4. Current Loop connector | - connector enabling communication via a digital current loop 4-20mA, |
| 5. RS-485 / RS-422 connector | - connector enabling communication via RS-485 and RS-422. The connector has an additional 5 VDC output for a radiomodem:
5V - 5 VDC power supply;
A - RS-485 and RS-422 interface non-inverting line;
B - RS-485 and RS-422 interface inverting line;
GND - RS-485 and RS-422 interface GND line; |
| 6. Brightness sensor connector | - connector to which the price display automatic brightness control sensor is connected, |
| 7. LEDs | - status LEDs signalling the device operation:
PW - green LED - signals powering the controller,
ST - red LED - signals the device status,
RM - red LED - signals receiving a signal from the remote control,
WF - blue LED - signals Wi-Fi connection, |
| 8. Multifunction button | - button for adding a remote control to the controller. |

8.3 Electrical connection diagram - LAN

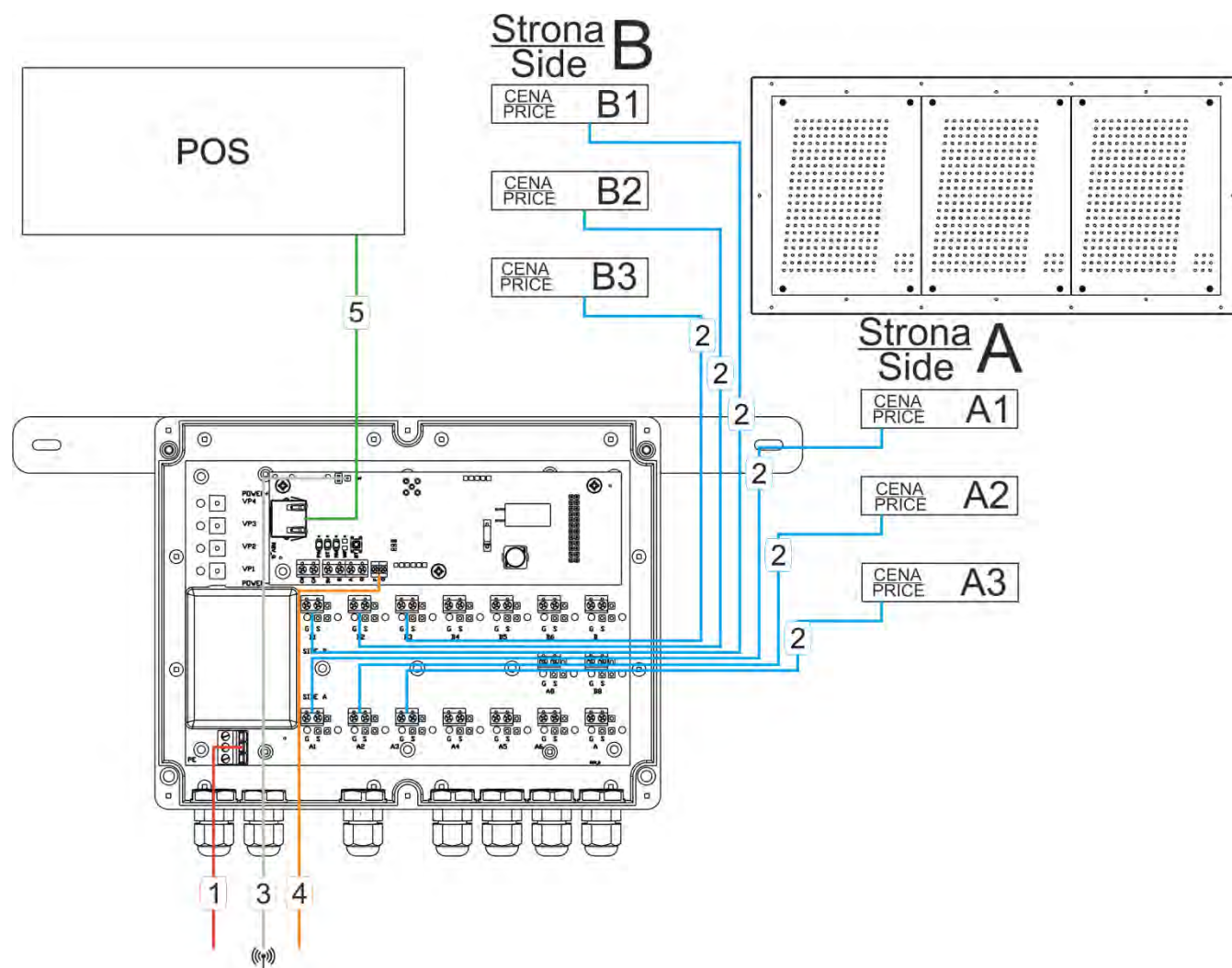

Fig. 7

Legend:

- Red -1-** - 3 x 1mm² cable of the length of 2 m (core markings and connection method: blue - N, brown - L, yellow-and-green - PE); controller power lead,
- Blue -2-** - 2 x 0.5 mm² cable of the length of 5 m (core markings and connection method: white - S, green (or brown) - G); signal cable connecting price modules with the controller,
- Grey -3-** - 5-metre long antenna cable.
- Orange -4-** - 2 x 0.5 mm² cable of the length of 2 m (core markings and connection method: red - F, black - GND); automatic brightness control sensor cable,
- Green -5-** - 2-metre long LAN cable terminated with an RJ-45 Ethernet plug.

8.4 Electrical connection diagram - Wi-Fi + LAN

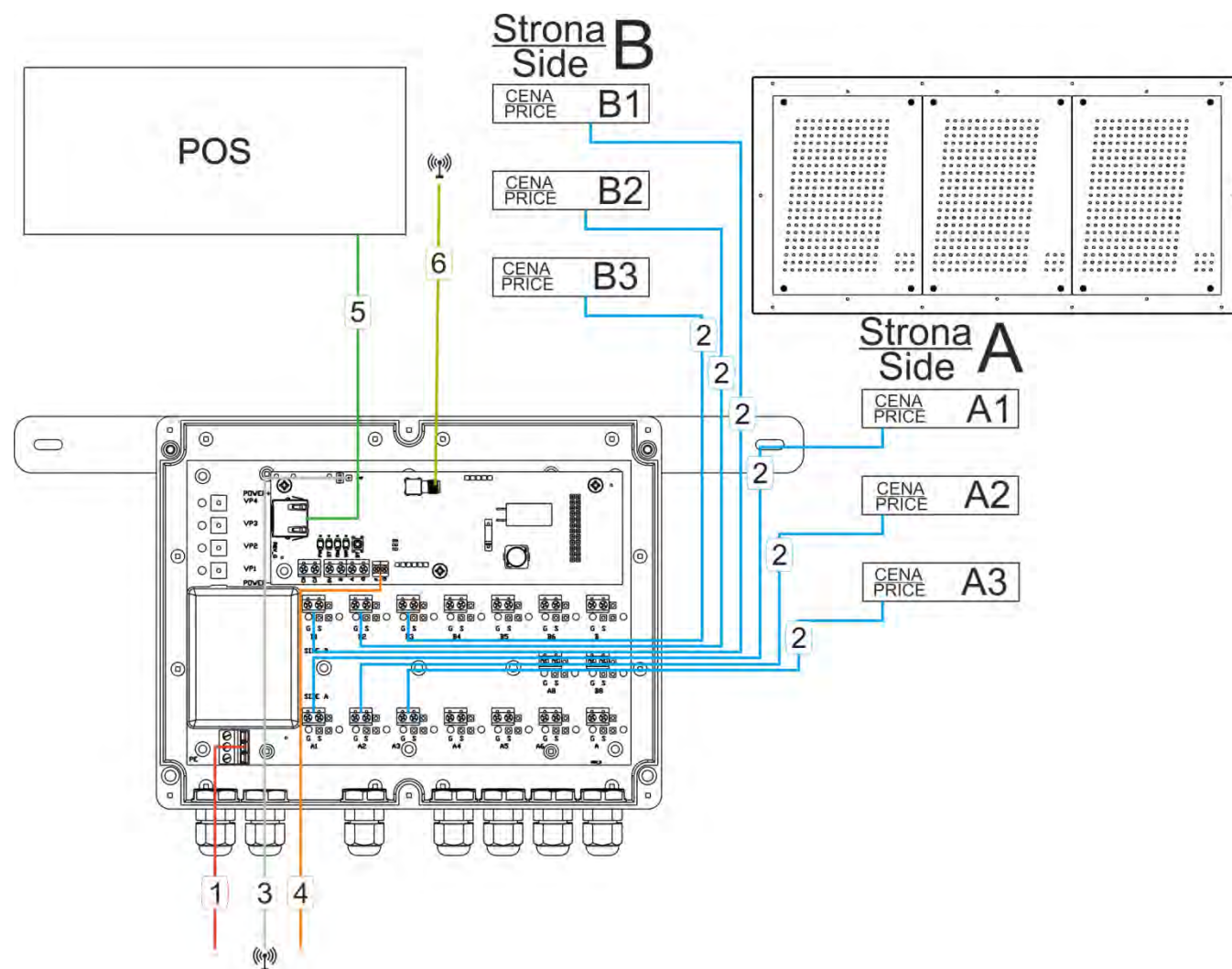

Fig. 8

Legend:

- Red -1-** - 3 x 1 mm² cable of the length of 2 m (core markings and connection method: blue - N, brown - L, yellow-and-green - PE); controller power lead,
- Blue -2-** - 2 x 0.5 mm² cable of the length of 5 m (core markings and connection method: white - S, green (or brown) - G); signal cable connecting price modules with the controller,
- Grey -3-** - 5-metre long antenna cable.
- Orange -4-** - 2 x 0.5 mm² cable of the length of 2 m (core markings and connection method: red - F, black - GND); automatic brightness control sensor cable,
- Green -5-** - 2-metre long LAN cable terminated with an Ethernet RJ-45 plug.
- Golden -6-** - 1.1-metre long Wi-Fi antenna cable.

8.5 Electrical connection diagram - Radiomodem option

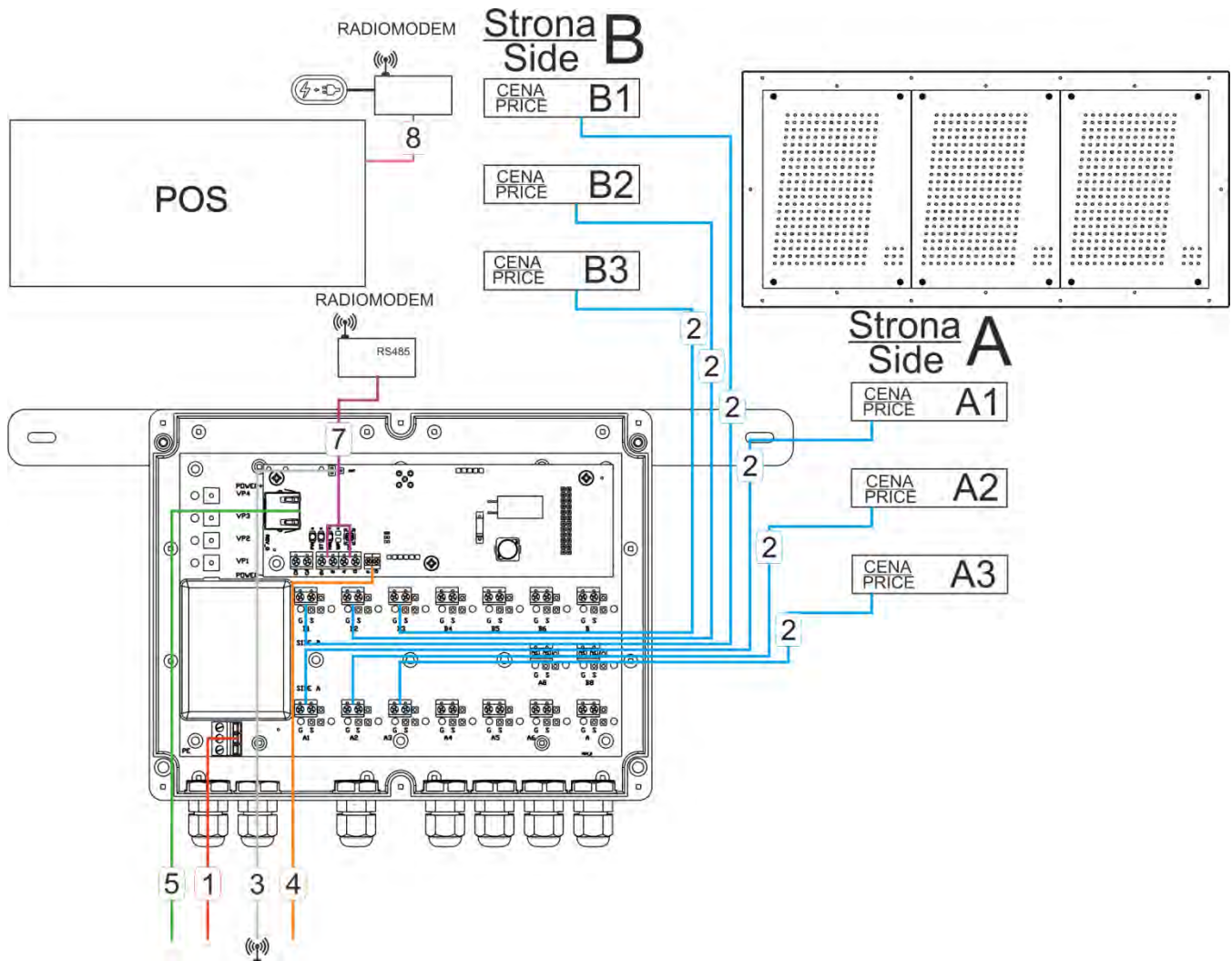

Fig. 9

Legend:

- Red -1-** - 3 x 1mm² cable of the length of 2 m (core markings and connection method: blue - N, brown - L, yellow-and-green - PE); controller power lead,
- Blue -2-** - 2 x 0.5 mm² cable of the length of 5 m (core markings and connection method: white - S, green (or brown) - G); signal cable connecting price modules with the controller,
- Grey -3-** - 5-metre long antenna cable.
- Orange -4-** - 2 x 0.5 mm² cable of the length of 2 m (core markings and connection method: red - F, black - GND); automatic brightness control sensor cable,
- Green -5-** - 2-metre long LAN cable terminated with an Ethernet RJ-45 plug.
- Purple -7-** - 4 x 0.75 mm² cable of the length of 2 m (core markings and connection method: white - A, green - B, red - 5V, black - GND; alternative core markings: yellow - A, white - B, brown - 5V, green - GND); cable connecting the radiomodem with the controller,
- Pink -8-** - RS-232 interface cable terminated with DE9 plugs,

8.6 Electrical connection diagram - RS-485

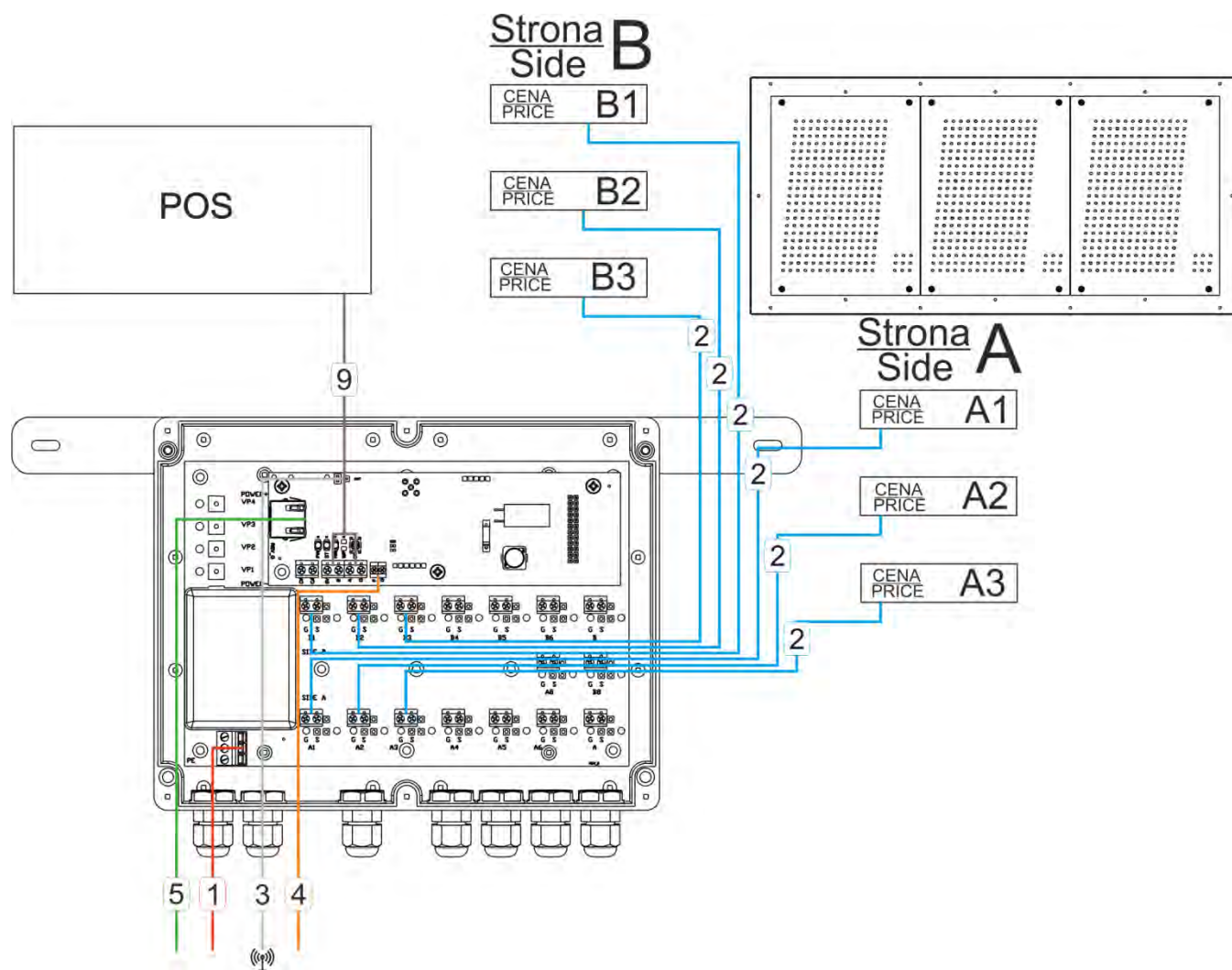

Fig. 10

Legend:

- Red -1-** - 3 x 1mm² cable of the length of 2 m (core markings and connection method: blue - N, brown - L, yellow-and-green - PE); controller power lead,
- Blue -2-** - 2 x 0.5 mm² cable of the length of 5 m (core markings and connection method: white - S, green (or brown) - G); signal cable connecting price modules with the controller,
- Grey -3-** - 5-metre long antenna cable.
- Orange -4-** - 2 x 0.5 mm² cable of the length of 2 m (core markings and connection method: red - F, black - GND); automatic brightness control sensor cable,
- Green -5-** - 2-metre long LAN cable terminated with an Ethernet RJ-45 plug.
- Brown -9-** - RS-485 interface cable.

8.7 Electrical connection diagram - RS485/RS232 converter option

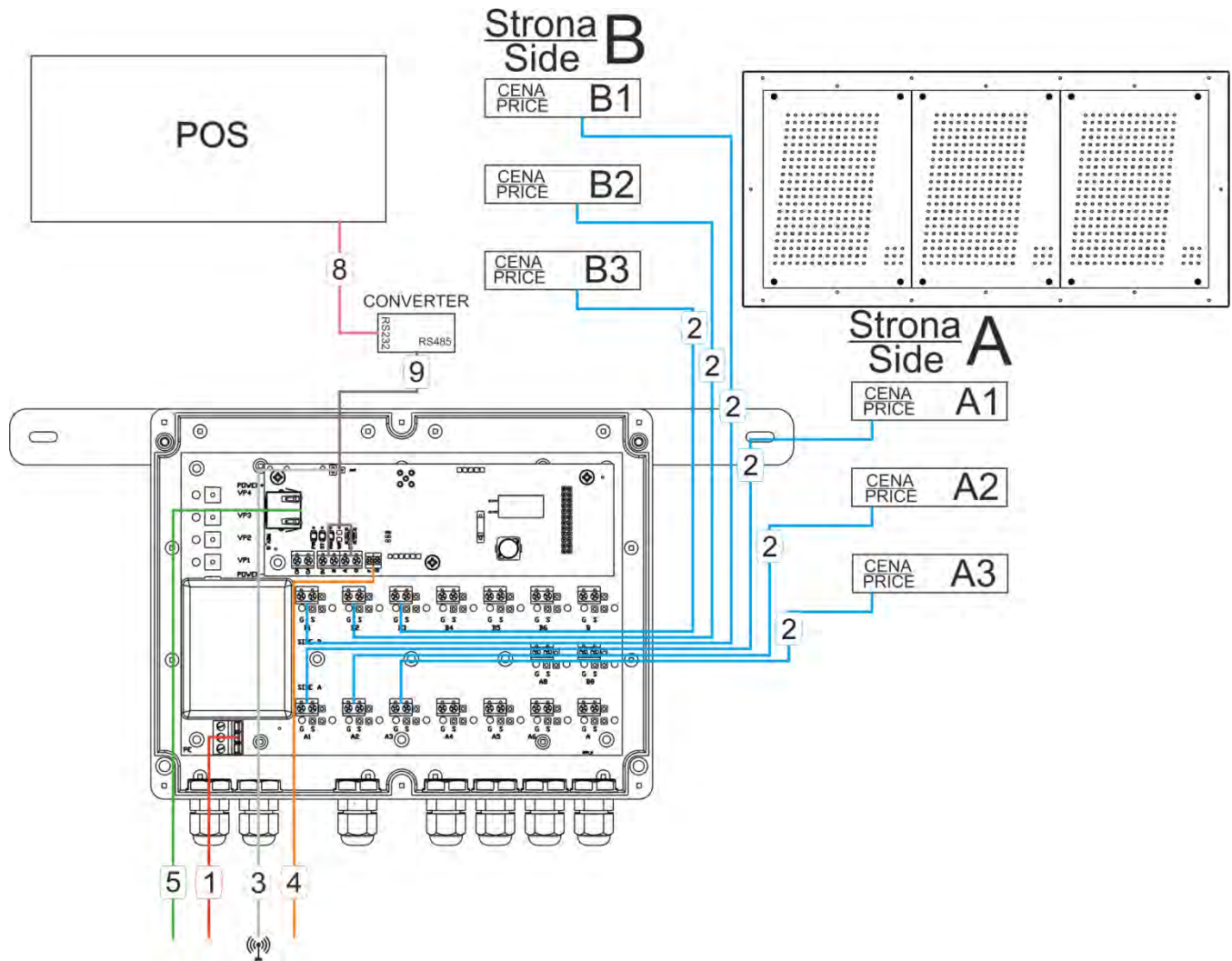
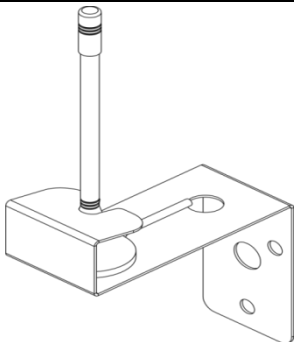
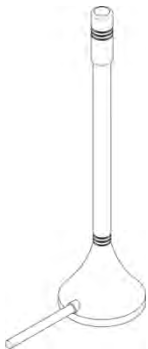
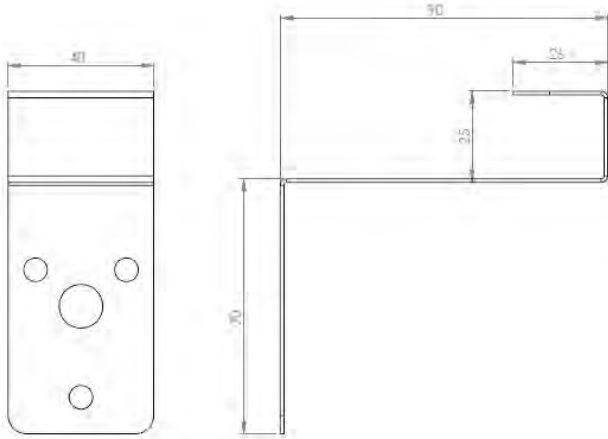
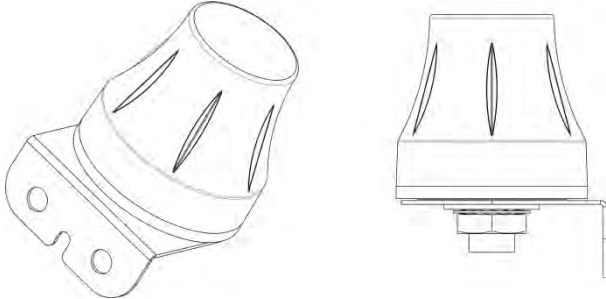



Fig. 11

Legend:

- Red -1-** - 3 x 1mm² cable of the length of 2 m (core markings and connection method: blue - N, brown - L, yellow-and-green - PE); controller power lead,
- Blue -2-** - 2 x 0.5 mm² cable of the length of 5 m (core markings and connection method: white - S, green (or brown) - G); signal cable connecting price modules with the controller,
- Grey -3-** - 5-metre long antenna cable.
- Orange -4-** - 2 x 0.5 mm² cable of the length of 2 m (core markings and connection method: red - F, black - GND); automatic brightness control sensor cable,
- Green -5-** - 2-metre long LAN cable terminated with an Ethernet RJ-45 plug.
- Pink -8-** - RS-232 interface cable terminated with DE9 plugs,
- Brown -9-** - 2 x 0.5 mm² cable (core markings and connection method: white - A, green (or brown) - B); RS-485 interface cable.

9 Accessories

 <p style="text-align: center;">Fig. 12</p>	 <p style="text-align: center;">Fig. 13</p>	<p>Antenna (Fig. 13) with product code: 103-01-03,</p> <ul style="list-style-type: none"> - cable: RG174, - cable length: 5 m, - gain: 3.5 dB, - vertical polarization, - weight: 60 g, - dimensions: Ø30x140 mm, - colour: black, - operating temperature -45°C~+75°C, - waterproof housing.
 <p style="text-align: center;">Fig. 14</p>	<p>Mounting the antenna (Fig. 14):</p> <ul style="list-style-type: none"> - carbon steel (DC01), - mounting material thickness: 1 mm, <p>Holes:</p> <ul style="list-style-type: none"> - 2 x Ø 12 holes for routing the antenna cable, - 3 x Ø 6,5 mounting holes. 	
 <p style="text-align: center;">Fig. 15</p>	<p>WiFi antenna (Fig. 15)(optional):</p> <ul style="list-style-type: none"> - requires a controller with an additional WiFi module installed, - cable: RG174, - gain: 2-3 dB, - linear polarization, - colour: black, - operating temperature -40°C~+85°C, - ingress protection rating: IP-67. 	
 <p style="text-align: center;">Fig. 16</p>	<p>RCR-01 remote control with product code 102-02-11:</p> <ul style="list-style-type: none"> - dimensions: 125x56x7,3 mm, - remote control power supply: CR2032 battery, - ingress protection rating: IP-50, - weight: 38 g. 	

10 Disposal and recycling

10.1 Packaging material recycling

The packaging elements must be segregated and, then, recycled in accordance with the local executive regulations on waste disposal.

10.2 Device disposal

The device must not be disposed of with normal municipal waste!

In accordance with Directive 2012/19/EC (WEEE), the user is obliged to transfer the damaged or destroyed device to the appropriate disposal facility if there is no economically justified repair possibility.



11 Most common installation errors

1. Boxes mounted contrary to the manual, e.g. with the cables facing up.
2. LED modules installed contrary to the diagram, i.e. exchanged order of module addresses.
3. Drilling additional mounting points or holes in the collective boxes.
4. Connecting the signal anode and cathode (white and green cores) to two different ports of the controller.