

DEVICE USER MANUAL

Digital display (price pylon) controlled by a radio remote control

1. Introduction

The price pylon (price tower) is designed to display the prices of any products. The device allows you to display the prices of seven items, while each price may be composed of maximum six digits and one coma. The price of a given product may be displayed on two price displays, one per each side of the price pylon. The price display brightness may be set manually or may be automatically adjusted to current lighting conditions (co-operation with ambient light sensor).

2. User manual

The basic method of configuring the device is using the radio remote control through the user menu. **Fig. 1** shows the remote control.

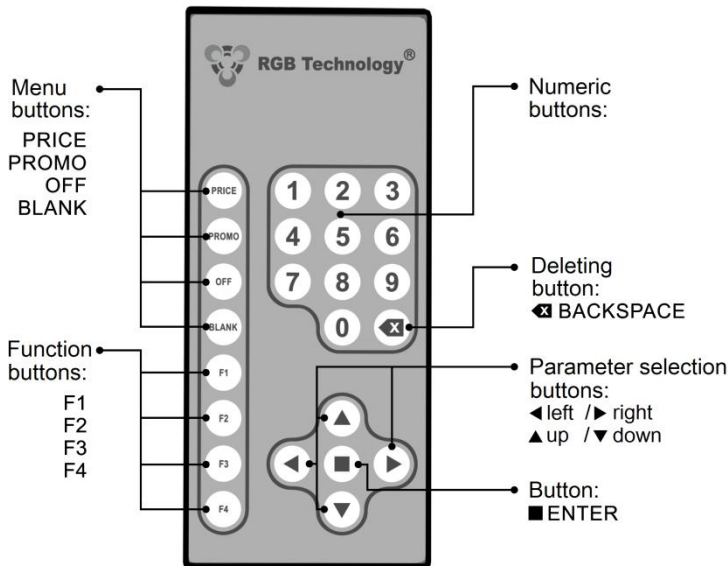

Fig. 1. Radio remote control

To change the price:

- 1) Enter the price change menu by pressing the **PRICE** button. Entering the menu will be confirmed by the animation generated on the price displays.
- 2) Using the **↑** and **↓** buttons, select the price which should be changed. The indicated price will be highlighted by increasing its brightness.
- 3) Using the numeric buttons, enter the value of the indicated price.
- 4) Confirm the price value by pressing the **ENTER** button or the **↑** and **↓** buttons. After pressing **ENTER**, the value will be saved and you will exit the menu, which will be confirmed by the animation generated on the price displays. Using the **↑** and **↓** buttons, you may choose another price to modify - it means moving to subpoint 2) of this description. Using the **PRICE** button will result in exiting the menu – if it is used during entering the value, then, when exiting the menu, it will not be saved.

To activate/deactivate signalling a promotion (product price flashing):

- 1) Enter the parameter change menu by pressing the **PROMO** button. Entering the menu will be confirmed by the animation generated on the price displays.
- 2) Using the **↑** and **↓** button, select the product, the parameter of which should be changed. The indicated price will be highlighted by increasing its brightness.
- 3) Using the **ENTER** button, activate/deactivate the function for a given product. Each time the button is pressed, the parameter value will be changed to the opposite one. The parameter activity for the product in the menu will be signalled by the price flashing.
- 4) Finish setting the promotion signalling by pressing the **PROMO**, **BACKSPACE**, **↑** and **↓** buttons. After pressing **PROMO** or **BACKSPACE**, you will exit the menu, which will be confirmed by the animation generated on the price displays. Using the **↑** and **↓** buttons, you should choose another price to modify - it means moving to subpoint 2) of this description. Using the **PROMO** button will result in exiting the menu.

To activate/deactivate the product price blanking:

- 1) Enter the parameter change menu by pressing the **OFF** button. Entering the menu will be confirmed by the animation generated on the price displays.
- 2) Using the **↑** and **↓** buttons, select the product, the parameter of which should be changed. The indicated price will be highlighted by increasing its brightness.
- 3) Using the **ENTER** button, activate/deactivate the function for a given product. Each time the button is pressed, the parameter value will be changed to the opposite one. The parameter activity for the product in the menu will be signalled by displaying in the price field: "___".
- 4) Finish setting the price blanking by pressing the **OFF**, **BACKSPACE**, **↑** and **↓** buttons. After pressing **OFF** or **BACKSPACE**, you will exit the menu, which will be confirmed by the animation generated on the price displays. Using the **↑** and **↓** buttons, you should choose another product to modify - it means moving to subpoint 2) of this description.

To activate/deactivate signalling the lack of a product:

- 1) Enter the parameter change menu by pressing the **BLANK** button. Entering the menu will be confirmed by the animation generated on the price displays.
- 2) Using the **↑** and **↓** buttons, select the product, the parameter of which should be changed. The price of the selected product will be highlighted by increasing its brightness.
- 3) Using the **ENTER** button, activate/deactivate the function for a given product. Each time the button is pressed, the parameter value will be changed to the opposite one. The parameter activity for the product in the menu will be signalled by displaying in the price field: "---".
- 4) Finish setting the signalling of the lack of the product by pressing the **BLANK**, **BACKSPACE**, **↑** and **↓** buttons. After pressing **BLANK** or **BACKSPACE**, you will exit the menu, which will be confirmed by the animation generated on the price displays. Using the **↑** and **↓** buttons, you should choose another product to modify - it means moving to subpoint 2) of this description.

Note: Activating any parameter from a given product parameter group: promotion, blanking, the lack of the product, will deactivate the other parameters. For example: activating the promotion signalling (the product price flashing) will deactivate the product blanking or the lack of the product.

Note: It is possible to quickly switch between the product price change menu and its parameter modifying menu (promotion, blanking, the lack of the product). When you are in one of the mentioned menus, use the **PRICE**, **PROMO**, **OFF** and **BLANK** buttons to quickly switch between the menus. After switching, it is remembered which product was indicated. Switching is signalled by the animation generated on the price displays.

To change the position of the decimal separator:

- 1) Enter the decimal separator position change menu by pressing, in turn, the **F1** button and the **ENTER** button within an interval of no more than 3 seconds.

- Using the **↑** and **↓** buttons, select the product, the parameter of which should be changed. The price of the selected product will be highlighted by increasing its brightness.
- Using the **→** and **←** buttons, set the position of the decimal point. Setting the separator position after the last digit in the price deactivates its display.
- Finish setting the product decimal separator position by pressing the **ENTER**, **↑** or **↓** button. After pressing the **ENTER** button, you will exit the menu, which will be confirmed by the animation generated on the price displays. Using the **↑** and **↓** buttons, you may choose other products to modify - it means moving to subpoint 2) of this description. Using the **F1** or **BACKSPACE** buttons will result in exiting the menu without saving the changes in the modified product.

To change the display brightness control mode: automatic/manual:

- Enter the display brightness parameter change menu by pressing, in turn, the **F2** button and the **ENTER** button within an interval of no more than 3 seconds.
- Using the **↑** and **↓** buttons, select the **P1** option and confirm it with the **ENTER** button.
- Using the **↑** and **↓** buttons, select the brightness level: A - automatic control based on the light sensor, 00 to 99 manual brightness value (the automatic control will be disabled).
- Finish setting the brightness control mode by pressing the **ENTER** button. Then, the entered values will be saved and you will exit to the P1, P2, P3 selection menu. Use the **F2** or **BACKSPACE** button, which will be followed by the exit from the menu confirmed by the animation generated on the price displays.

To change the display brightness percentage coefficient for the A or B side, you should:

- Enter the display brightness parameter change menu by pressing, in turn, the **F2** button and the **ENTER** button within an interval of no more than 3 seconds.
- Use the **↑** and **↓** buttons to select the P2 option for setting the display A side or P3 for the B side, and, then, confirm your choice with the **ENTER** button.
- Using the **↑** and **↓** buttons, select the brightness percentage coefficient for a given display side.
- Finish setting the brightness percentage coefficient by pressing the **ENTER** button. Then, the entered values will be saved and you will exit to the P1, P2, P3 selection menu. Use the **F2** or **BACKSPACE** button, which will be followed by the exit from the menu, confirmed by the animation generated on the price displays.

Note: The display brightness percentage coefficient for the A or B side is intended to ensure adequate legibility of the displayed content in two-sided displays, where one of the sides is more strongly illuminated (e.g. by the sun from the south side). It should be noted that if the automatic brightness control based on the light sensor was activated in the P1 menu and the brightness percentage coefficient for the A and B sides was set, the brightness of the display sides will be controlled, taking into account the set coefficients for the side, based on the ambient light sensor indications.

To change the settings of the dusk sensor/relay, you should:

- Enter the display brightness parameter change menu by pressing, in turn, the **F2** button and the **ENTER** button within an interval of no more than 3 seconds.
- Using the **↑** and **↓** buttons, select the P4 option and confirm it with the **ENTER** button.
- The current brightness level value read from the sensors built into the price modules will be displayed in the **bXX** format, where XX is the current brightness level percentage value read from the price modules. After 3 seconds or after pressing the **ENTER** button again, it will switch to the set brightness level value, below which the dusk sensor relay output will be activated. If the function is disabled, the message "Off" will appear.
- Use the **↑** and **↓** buttons to select the brightness level percentage value below which the dusk sensor output will be activated. If the function is to be inactive, use the **↓** button until the message "Off" appears.
- Finish setting the dusk sensor value by pressing the **ENTER** button. Then, the entered values will be saved and you will exit to the P1, P2, P3, P4 selection menu. Use the **F2** or **BACKSPACE** button, which will be followed by the exit from the menu, confirmed by the animation generated on the price displays.

To change the digit font:

- 1) Enter display parameter menu by pressing, in turn, the **F3** button and the **ENTER** button within an interval of no more than 3 seconds.
- 2) Use the **↑** and **↓** buttons to select the Fn option, and, then, confirm it with the **ENTER** button.
- 3) Using the **↑** and **↓** buttons, select the required font.
- 4) Finish setting the font by pressing the **ENTER** button. Then, the entered values will be saved and you will exit to the Fn, Fu, FL, Fd selection menu. Use the **F3** or **BACKSPACE** button, which will be followed by the exit from the menu confirmed by the animation generated on the price displays.

To set the "Upper Index" mode (showing the fraction of the price by the font of a smaller size):

- 1) Enter the display parameter menu by pressing, in turn, the **F3** button and the **ENTER** button within an interval of no more than 3 seconds.
- 2) Use the **↑** and **↓** buttons to select the Fu option, and, then, confirm it with the **ENTER** button.
- 3) Using buttons **↑** and **↓** select the Upper Index mode.
- 4) Finish setting the Upper Index mode by pressing the **ENTER** button. Then, the entered values will be saved and you will exit to the Fn, Fu, FL, Fd selection menu. Use the **F3** or **BACKSPACE** button, which will be followed by the exit from the menu confirmed by the animation generated on the price displays.

To activate/deactivate the display of leading zeros:

- 1) Enter the display parameter menu by pressing, in turn, the **F3** button and the **ENTER** button within an interval of no more than 3 seconds.
- 2) Use the **↑** and **↓** buttons to select the FL option, and, then, confirm it with the **ENTER** button.
- 3) Using the **↑** and **↓** buttons, select the product, the parameter of which should be changed. The price of the selected product will be highlighted by increasing its brightness.
- 4) Using the **ENTER** button, activate/deactivate the function for a given product. Each time the button is pressed, the parameter value will be changed to the opposite one. The parameter activity for the product in the menu will be signalled by displaying the price of the "0000" value, while the inactivity with "0".
- 5) Finish setting the display of the product leading zeros by pressing the **F3**, **↑** or **↓**.button. After pressing **F3**, you will exit the menu which will be confirmed by the animation generated on the price displays. Using the **↑** and **↓** buttons, you may choose another product to modify - it means moving to subpoint 2) of this description.

To change the decimal separator font:

- 1) Enter the display parameter menu by pressing, in turn, the **F3** button and the **ENTER** button within an interval of no more than 3 seconds.
- 2) Use the **↑** and **↓** buttons to select the Fd option, and, then, confirm it with the **ENTER** button.
- 3) Using the **↑** and **↓** buttons, select the required font.
- 4) Finish setting the font by pressing the **ENTER** button. Then, the entered values will be saved and you will exit to the Fn, Fu, FL, Fd selection menu. Use the **F3** or **BACKSPACE** button, which will be followed by the exit from the menu confirmed by the animation generated on the price displays.

To set the presentation of "Information Module":

- 1) Enter the "Information Module" parameter menu by pressing, in turn, the **F4** button and the **ENTER** button within an interval of no more than 3 seconds. Entering the menu will be confirmed by the animation generated on the price displays.
- 2) Use the **↑** and **↓** buttons to select which presentation should be displayed. The presentation number (1P, 2P, 3P etc.) will be displayed on the first price and the presentation will be displayed on the "Information Module".
- 3) Confirm the choice with the **ENTER** button, which will be followed by the exit from the menu confirmed by the animation generated on the price displays.